

# COBREC®



Catálogo de Aplicações  
**LINHA MOTO 2023**

**TMD**FRICCIÓN



# COBREG<sup>®</sup>

## Segurança e alta performance

seja qual for o seu estilo

A linha de produtos mais completa

Desenvolvemos linhas especiais para todas as categorias de motos, com a linha mais extensa do mercado, dispomos de produtos de alta tecnologia para que você tenha a segurança e a performance necessária seja qual for o seu estilo de pilotagem.

Nossos produtos são extensivamente testados em nosso avançado centro de pesquisa e desenvolvimento, para garantir aos nossos usuários o melhor conforto com a maior segurança na utilização dos nossos produtos.



LINHA  
**Street**

LINHA  
**CUSTOM**

LINHA  
**Racing**

LINHA  
**Racing  
Extreme**

# LINHA **Street**



Quando a questão é a utilização em ambientes urbanos e que exigem grande mobilidade em frenagens com performance e segurança, a **Linha Street** é a escolha ideal a ser utilizada para todas as motos de até 400 CC, que exigem melhor poder de frenagem e baixo desgaste do disco/cubo.

Além das pastilhas e patins de freio, conheça também os demais produtos que fazem parte da gama da **Linha Street**.

## Sensibilidade à velocidade

As pastilhas de freio **Cobreq Street** possuem, em diferentes faixas de velocidade, níveis de atrito adequados as aplicações, mesmo com a motocicleta carregada ou em condições de trânsito adversas.

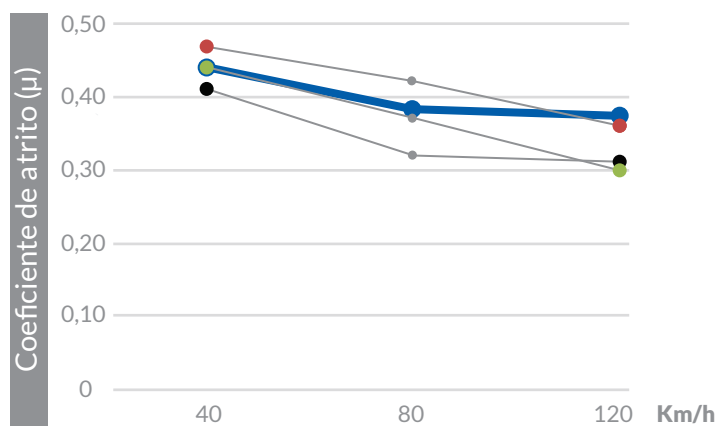

● **COBREQ Street** ● Concorrente A ● Concorrente B ● Concorrente C

## Sensibilidade à temperatura

Comparando as pastilhas de freio **Cobreq Street** com demais materiais do mercado, observamos menor variação do nível de atrito em todas as faixas de temperatura, o que resulta em melhor performance.

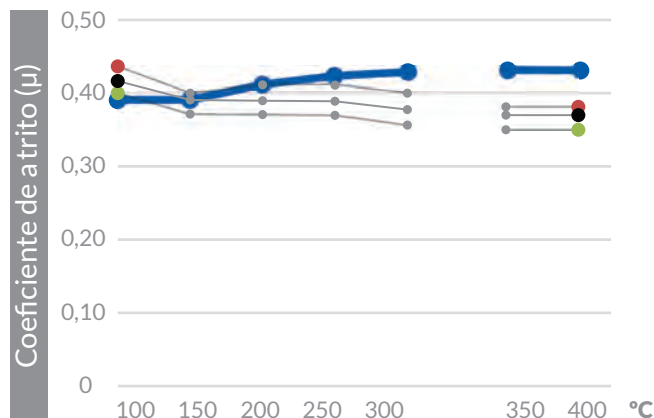

● **COBREQ Street** ● Concorrente A ● Concorrente B ● Concorrente C

LINHA  
**Street**



## Distância de Parada 80 a 30 km/h

A distância de parada proporcionada pelas pastilhas de freio **Cobreq Street**, é a menor, o que traduz-se em mais segurança ao condutor e eficiência de resposta quando acionado os freios.

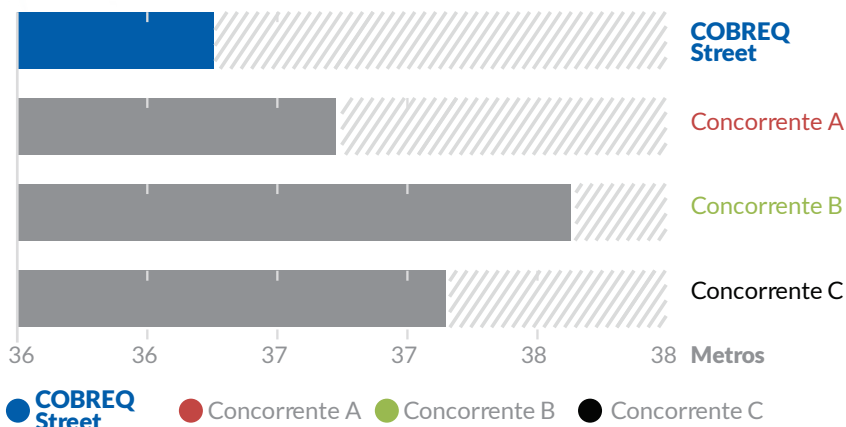

## Desgaste de Disco

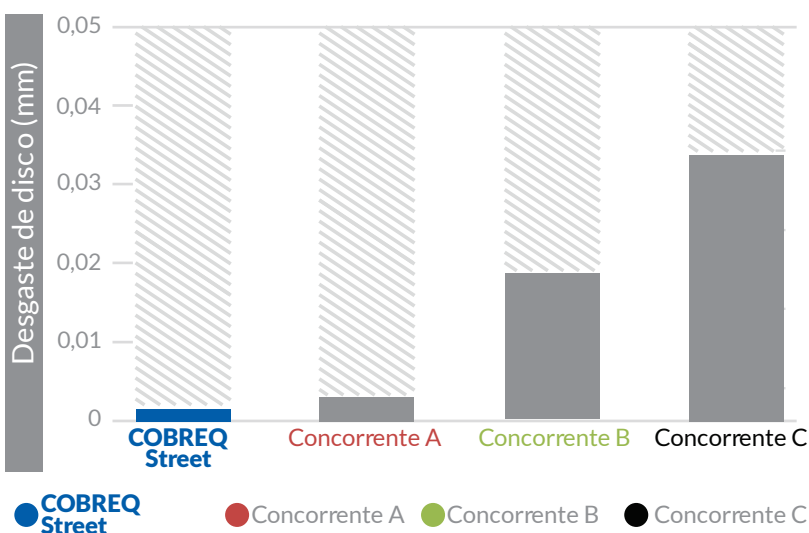

As pastilhas de freio **Cobreq Street** oferecem menor desgaste de disco em comparação aos demais materiais do mercado, trazendo ao consumidor maior durabilidade do conjunto.

## Vantagens

Algumas vantagens em utilizar pastilhas de freio **Cobreq Street**:

- ▶ **A estabilidade e integridade física das pastilhas de freio Cobreq Street**, mesmo que expostas a diversas situações de rodagem - velocidade, temperatura e carga - conferem condução segura e frenagem precisa.
- ▶ **A excelente durabilidade** das pastilhas de freio Cobreq Street, associada ao baixo nível de desgaste do disco, gera maior autonomia a motocicleta e consequente autonomia ao usuário.
- ▶ **Segurança: a performance superior** das pastilhas de freio Cobreq Street, contribui para frenagens mais seguras, pois traduzem em menor distância de parada a estabilidade da motocicleta.

LINHA

**CUSTOM**



Para as motocicletas estradeiras, a **Linha Custom** foi especialmente desenvolvida diferente do processo tradicional e caracteriza-se por possuir alto teor metálico sendo produzido por metalurgia a pó.

Este material sinterizado, segue as mais rígidas normas dos fabricantes originais compondo também isolador e garantindo assim melhor desempenho e mais conforto.

LINHA  
**Racing**



Para aplicações de alta performance a **Linha Racing** da **Cobreq** é a escolha ideal, essa aplicação foi especialmente projetada para motocicletas a partir de 500 CC, que exigem um melhor poder de frenagem devido as altas temperaturas, com menor desgaste das pastilhas e dos discos de freios, em sua composição são utilizados materiais de fibra de aramidas e kévelar e testados em ambientes extremos de competições como Moto GP, Superbike, Stock Car e F-Truck, assegurando a qualidade e confiabilidade da marca.

NOVA  
FORMULAÇÃO

LINHA  
**Racing  
Extreme**



As pastilhas de freio da **Linha Cobreq Racing Extreme** foram desenvolvidas em pesquisas e avaliações durante um período superior a 2 anos, contando com a atuação, tanto no Brasil quanto na Europa, de profissionais especializados em novas tecnologias de materiais, além de laboratórios de testes e aplicação.

O material de atrito cerâmico **Cobreq Racing Extreme** tem como características especiais, matérias-primas e fórmulas inovadoras, além de exigentes processos de fabricação, resultando em um material de atrito diferenciado, com baixo uso de materiais orgânicos, portanto mais resistente e com nível de atrito mais estável em diferentes faixas de temperatura.

## Sensibilidade à velocidade

O material de atrito **Cobreq Racing Extreme** possui excelente estabilidade a diferentes velocidades de frenagem, tanto em uso diário em ambientes urbanos relacionados a baixas velocidades (40 km/h, por exemplo), quanto em condições severas de performance que exigem do sistema de freio uma maior estabilidade e resposta, como a 200 km/h, por exemplo.

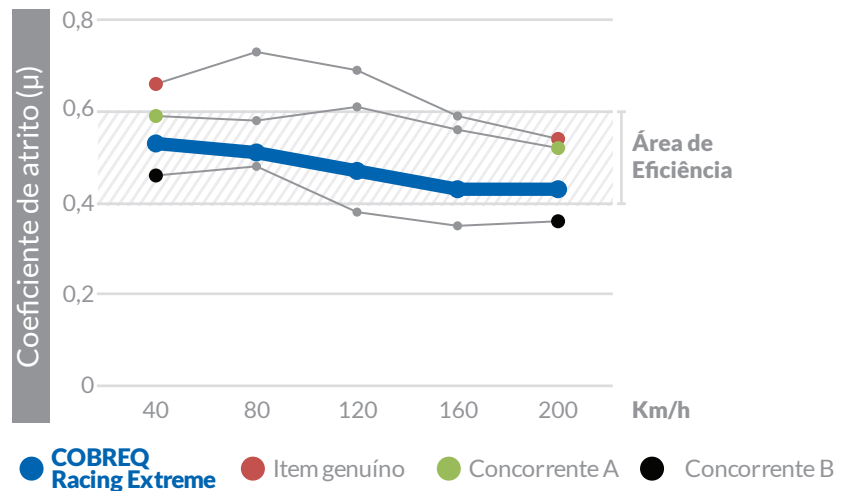

## Sensibilidade à temperatura

No comparativo de exposição às variações de temperatura, o material de atrito **Cobreq Racing Extreme** demonstra clara superioridade em comparação aos demais materiais concorrentes do mercado e até quando comparado ao item genuíno. A sua variação de coeficiente de atrito se mantém constante, desde temperaturas normais de uso como 100°C até condições severas de 500°C.

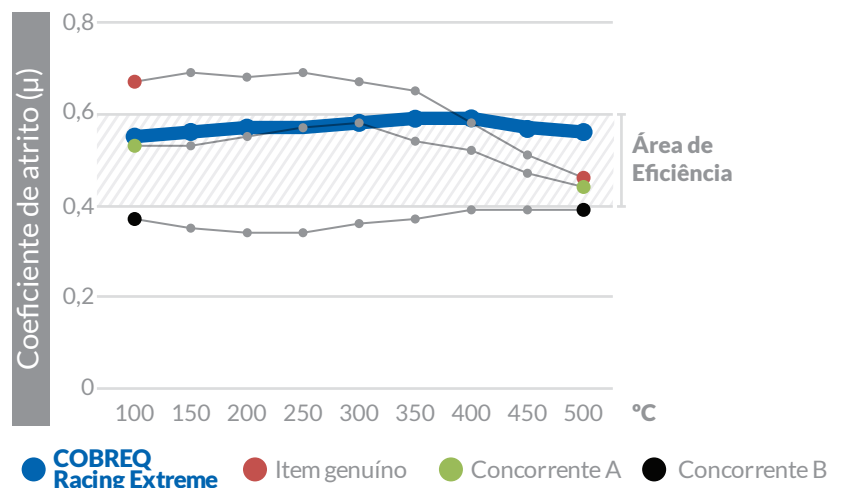

# LINHA **Racing Extreme**

**NOVA  
FORMULAÇÃO**



## Distância de Parada **80 a 30 km/h**

Além do conceito de alta performance, o material de atrito **Cobreq Racing Extreme** foi desenvolvido seguindo rigorosos critérios relacionados à segurança para o condutor ou piloto, no qual possui uma resposta muito superior aos demais quando comparado ao resultado da distância de parada.

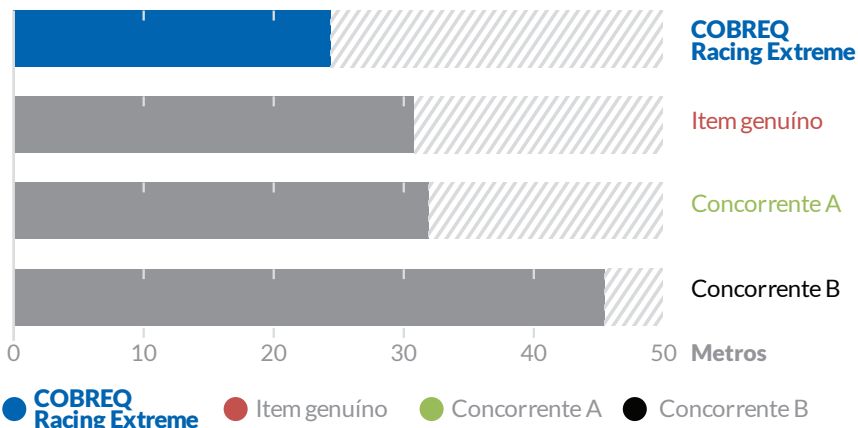

## Desgaste de Disco

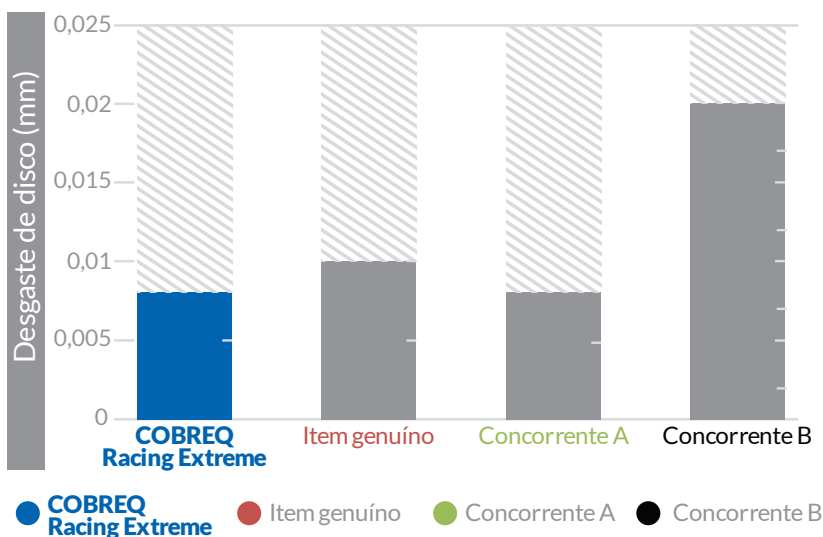

O material **Cobreq Racing Extreme** apresenta ótimo compromisso em relação a desgaste de disco em comparação com demais qualidades de materiais de atrito existentes no mercado.

## Vantagens

Algumas vantagens em utilizar material de atrito cerâmico:

- **Resiste à altas temperaturas sem deterioração.** O efeito que chamamos de fading, a redução do nível do coeficiente de atrito em altas temperaturas, devido ao uso prolongado do freio, é minimizado devido a ótima estabilidade do material.
- **A estabilidade do coeficiente de atrito é melhor** que as pastilhas de freios de composição semimetálicas.
- **Segurança:** como o desempenho do material de atrito **Cobreq Racing Extreme** é superior, cada centímetro diminuído na hora da frenagem, reflete em segurança.
- **O desgaste do disco é reduzido** e isso, gera benefícios para o consumidor.

## Patim de freio

Desenvolvido especialmente para utilização em motocicletas, tanto em freios traseiros, quanto dianteiros. São fabricadas em material de baixa densidade com alta resistência ao cisalhamento. Outro diferencial é que todos os patins são fornecidos com molas de retorno garantindo o melhor funcionamento do sistema de freio.

São projetados para atender os padrões estabelecidos para os níveis de atrito das montadoras conforme norma SAE J661 proporcionando uma frenagem segura e baixo índice de desgaste do material.



## Cubo de roda Espelho Flange

Produzidos com uma liga de alumínio especial que alia um material mais leve e que cumpre com tranquilidade os requisitos de segurança estabelecidos.

A parte interna do anel é feita em aço e possui uma rugosidade que em contato com o patim de freio contribui para o bom desempenho do conjunto. Além disso, estes itens recebem pintura especial anticorrosiva, maior durabilidade. O projeto construtivo e componentes asseguram rodagem e frenagem perfeita.



## Disco de freio

O disco de freio Cobreq é composto com uma propriedade diferenciada de aço inoxidável 12Cr13, possui menor teor de carbono, tornando o produto com maior durabilidade e menor índice de desgaste se comparado com as outras marcas.



## Disco de embreagem

Os coeficientes estático e dinâmico dos Discos de Embreagem asseguram a estabilidade do arranque e a direção dinâmica necessários para uma boa condução. Os discos internos fazem o cubo da embreagem girar, transferindo a potência, enfim, para a transmissão/caixa de câmbio. Do eixo primário, eixo secundário (ligações com engrenagens), para o pinhão.



Quando a embreagem está no neutro ou quando se está pressionando o manete da embreagem, ela trabalha solta. Uma vez que se engrene a marcha e se acelera, elas trabalham unidas efetuando o repasse da força para a caixa de marchas, através do eixo primário e secundário, que está ligado ao pinhão, que faz girar a roda. Os Kits de Cubo, Disco e Platô da **COBREQ** disponibilizados ao mercado utilizam Disco de Embreagem nestes mesmos padrões de projeto.

## Kit de embreagem

O Kit Cubo, Platô e Disco de Embreagem é produzido com materiais com resistência superior e com disco de fricção adequado para o tipo de aplicação no qual a estabilidade dimensional e construtiva, garante que a embreagem abra e feche livremente sem desalinhamento do conjunto, evitando assim, “trancos e escorregamento”. Tudo isso para proporcionar uma pilotagem mais suave e segura.



## Cabos

A gama mais extensa de cabos de freios para quaisquer que seja a sua moto, desenvolvido com componentes de primeira qualidade, os nossos cabos foram desenvolvidos para suportar os ambientes mais críticos, dentro do nosso portfólio temos cabos para acelerador, afogador, embreagem, freio e velocímetro.



## Kit Transmissão

Composto por coroa, pinhão e corrente possui alta resistência ao desgaste e corrosão.

São produzidos em aço 1045 para oferecer o melhor desempenho para motos com até 300CC.

Certificado pelo INMETRO e com rendimento maior em comparação ao requerido pela norma.

O Kit Relação da **Cobreq** é o produto ideal quando se procura:

- Fácil instalação;
- Resistência ao desgaste/corrosão;
- Confiabilidade de um dos principais fornecedores de motopeças do Brasil;
- Produtos certificados pelo INMETRO;
- Carga de trabalho adequada para motos de 100cc até 300cc.



## Fluido de freio

DOT 3 e DOT 4 - Dentro da completa gama de produtos Cobreq, oferecemos também três fluidos de freios desenvolvidos especialmente para atender todas as exigências do mercado e em frascos de 200 ml, para que você tenha o melhor aproveitamento, e desempenho com o fluido adequado para a sua motocicleta



A

Street

Racing

Racing  
Extreme

CUSTOM

APLICAÇÃO	Ano									
<b>AGRALE</b>										
CITY 90	98>	-	N-947	-	-	-	-	-	-	-
DAKAR 50	98>	-	N-947	-	-	-	-	-	-	-
Dakar SXT 27.5-E	85>	85>	N-914	0318-CP	-	-	-	-	-	-
Dakar SXT 30.0	85>	85>	N-914	0318-CP	-	-	-	-	-	-
Elefant SXT 27.5	85>	85>	N-914	0318-CP	-	-	-	-	-	-
Elefant SXT 16.5	85>	85>	N-914	0318-CP	-	-	-	-	-	-
EXPLORER 200 30.0	-	92>	-	N-919	-	-	-	-	-	-
FORCE 50	98>	-	N-947	-	-	-	-	-	-	-
FORCE 90	98>	-	N-947	-	-	-	-	-	-	-
Legion 125	09>	-	N-1013	-	-	-	-	-	-	-
LEGION 125	-	98>	-	0321-CP	-	-	-	-	-	-
<b>AKT</b>										
AK 100 S	04>08	04>08	N-906	0320-CP	-	-	-	-	-	-
AK 100 SII	-	10>13	-	0304-CP	-	-	-	-	-	-
AK 110	04>09	-	N-941	0320-CP	-	-	-	-	-	-
AK 110 SII	10>13	-	N-941	-	-	-	-	-	-	-
AK 125 EVO	08>12	-	N-942	-	-	-	-	-	-	-
AK 125 EVO II	08>12	-	N-942	-	-	-	-	-	-	-
AK 125 NKD	11>12	-	0304-CP	-	-	-	-	-	-	-
AK 125 NKD	11>12	-	0320-CP	-	-	-	-	-	-	-
AK 125 NKDR	13>17	-	N-941	-	-	-	-	-	-	-
AK 125 SC DYNAMIC	09>13	-	N-1800	-	-	-	-	-	-	-
AK 125 SL	04>10	04>08	N-941	0320-CP	-	-	-	-	-	-
AK 125 TT	07>13	-	N-942	-	-	-	-	-	-	-
AK 150 BR	-	14>17	-	0320-CP	-	-	-	-	-	-
AK 150 EVO	08>12	-	N-942	-	-	-	-	-	-	-
AK 150 NE	08>12	-	N-942	-	-	-	-	-	-	-
AK 150 TT	-	07>13	-	0320-CP	-	-	-	-	-	-
AK 150 TT R	14>16	14>16	N-942	0320-CP	-	-	-	-	-	-
AK 200 SM	10>12	10>12	N-942	N-906	-	-	-	-	-	-
AK 200XM/SM	08>	08>	-	-	N-1828	-	N-1828C	-	-	-
AK 235 R	09>10	09>10	N-942	N-906	-	-	-	-	-	-
AK 235 R	08>	-	N-941	-	-	-	-	-	-	-
AK SPECIAL 110	10>13	10>13	N-941	0304-CP	-	-	-	-	-	-
CR4	-	18>	-	0302-CP	-	-	-	-	-	-
CR5 180	-	15>17	-	0302-CP	-	-	-	-	-	-
FLEX 110	-	12>16	-	0320-CP	-	-	-	-	-	-
FLEX 125	12>16	-	N-949	-	-	-	-	-	-	-
Komfort 115	09>12	09>12	N-954	0304-CP	-	-	-	-	-	-
RTX 150 UNISHOCK	14>16	-	N-942	-	-	-	-	-	-	-
TT 180 R	14>16	-	N-942	-	-	-	-	-	-	-
TT 180 X	15>17	-	N-942	-	-	-	-	-	-	-
TT ADVENTURE 250	15>	-	-	-	N-991	-	N-991C	-	-	-
<b>AME AMAZONAS</b>										
COUGAR 110	08>	08>	0304-CP	N-947	-	-	-	-	-	-
<b>APRILIA</b>										
AF-1 125	-	88>	-	N-914	-	-	-	-	-	-
Dorsoduro 1200. ABS	11>	11>	-	-	N-1804	N-932	N-1804C	N-932C	-	-
Dorsoduro Factory 750	10>	10>	-	-	N-1804	N-932	N-1804C	N-932C	-	-
ETV 1000 Caponod	01>	01>	-	-	N-934	N-1818	N-934C	N-1818C	-	-
ETV 1000 Caponod Rally Raid	04>	04>	-	-	N-934	N-1818	N-934C	N-1818C	-	-
MX 50	-	03>	-	N-914	-	-	-	-	-	-
PEGASO 650	95>	95>	-	-	N-934	-	N-934C	-	-	-
PEGASO 650 FACTORY	07>	07>	-	-	-	N-1073	-	N-1073C	-	-
PEGASO 650 i.e	01>	01>	-	-	N-934	N-932	N-934C	N-932C	-	-
PEGASO 650 i.e.	-	01>	-	-	-	N-1073	-	-	-	-
PEGASO 650 i.e. TUSCANI TIBET RAID	04>	04>	-	-	N-934	N-1073	N-934C	N-1073C	-	-
PEGASO 650 Strada	05>	05>	-	-	N-1804	N-932	N-1804C	N-932C	-	-
PEGASO 650 Strada	-	05>	-	-	-	N-1073	-	N-1073C	-	-
PEGASO 650 Trail	06>	06>	-	-	N-1804	N-932	N-1804C	N-932C	-	-
RS 250	97>02	-	-	-	N-1804	-	N-1804C	-	-	-
RS 250 PISTA	04>	-	-	-	N-1804	-	N-1804C	-	-	-
RS 4 125	-	11>	-	N-947	-	-	-	-	-	-

A-B

Street

Racing

Racing  
Extreme

CUSTOM

APLICAÇÃO

Ano

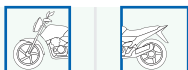

APLICAÇÃO	Ano		Street		Racing		Racing Extreme		CUSTOM	
<b>APRILIA</b>										
RS 50	-	96>99	-	N-914	-	-	-	-	-	-
RS 50 REPLICIA	-	00>	-	N-914	-	-	-	-	-	-
RST 1000 FUTURA	01>	01>	-	-	-	N-993	-	N-993C	-	-
RST Futura 1000	01>	01>	-	-	N-1804	-	N-1804C	-	-	-
RSV 1000 FACTORY PISTA	04>	04>	-	-	-	N-1818	-	N-1818C	-	-
RSV 1000 Mile	97>01	97>01	-	-	N-1804	N-1818	N-1804C	N-1818C	-	-
RSV 1000 Mile	02>	02>	-	-	N-1811	N-1818	N-1811C	N-1818C	-	-
RSV 1000 Mile NERA	04>	04>	-	-	N-1811	N-1818	N-1811C	N-1818C	-	-
RSV 1000 Mile R	01>	01>	-	-	N-1811	-	N-1811C	-	-	-
RSV 1000 Mile R	00	00	-	-	N-1804	N-1818	N-1804C	N-1818C	-	-
RSV 1000 MILLE SL FALCO/R	00>	00>	-	-	-	N-1818	-	N-1818C	-	-
RSV 1000 R Touno, ABS	10>	10>	-	-	N-1813	N-1818	N-1813C	N-1818C	-	-
RSV 1000 TUONO FIGHTER	03>05	03>05	-	-	N-1818	-	N-1818C	-	-	-
RSV 1000 TUONO R ABS	04>	04>	-	-	N-1818	-	N-1818C	-	-	-
RSV4 1000, ABS	09>	09>	-	-	N-1813	N-1818	N-1813C	N-1818C	-	-
RSV4-R 1000, ABS	09>	09>	-	-	N-1813	N-1818	N-1813C	N-1818C	-	-
RX 50	-	90>	-	N-914	-	-	-	-	-	-
RX 50 RACING	-	04>	-	N-914	-	-	-	-	-	-
STARCK 650	96>	96>	-	-	N-934	N-934C	-	-	-	-
SXV 450	06>	06>	-	-	-	-	-	N-1011C	-	-
SXV 550	06>	06>	-	-	-	-	-	N-1011C	-	-
V4 1000 R TUONO APRC ABS	14>	14>	-	-	N-1790	-	N-1790C	-	-	-
V4 1100 RR TUONO ABS	15>	15>	-	-	N-1790	-	N-1790C	-	-	-
V4 1100 RR TUONO FACTORY ABS	15>	15>	-	-	N-1790	-	N-1790C	-	-	-
<b>ASIA HERO</b>										
AH 110	98>04	-	N-941	-	-	-	-	-	-	-
<b>BAJAJ</b>										
ACTIV	06>	-	N-941	-	-	-	-	-	-	-
AGILITY	06>	06>	-	-	N-1828	-	N-1828C	-	-	-
AVENGER 220	14>17	14>17	-	-	N-993	-	N-993C	-	-	-
CALIBER 115	06>08	06>08	-	-	N-993	-	N-993C	-	-	-
DISCOVER 125	08>17	08>17	-	-	N-993	-	N-993C	-	-	-
DISCOVER 125 +	09>17	09>17	-	-	N-993	-	N-993C	-	-	-
DISCOVER 125 DTSI	14>17	14>17	-	-	N-993	-	N-993C	-	-	-
DISCOVER 125 ST	10>17	10>17	-	-	N-993	-	N-993C	-	-	-
DISCOVER 135	08>17	08>17	-	-	N-993	-	N-993C	-	-	-
DISCOVER 150 F	15>17	15>17	-	-	N-993	-	N-993C	-	-	-
PLATINO DRL 125	17>18	17>18	-	-	N-993	-	N-993C	-	-	-
PULSAR 135 LS	09>17	09>17	-	-	N-993	-	N-993C	-	-	-
PULSAR 150 AS	16>17	16>17	-	-	N-993	-	N-993C	-	-	-
PULSAR 180	04>06	04>06	-	-	N-993	-	N-993C	-	-	-
PULSAR 180 DTSI	07>09	07>09	-	-	N-993	-	N-993C	-	-	-
PULSAR 180 UG	04>17	04>17	-	-	N-993	-	N-993C	-	-	-
PULSAR 200 NS	13>17	13>17	-	-	-	N-932	-	N-932C	-	-
PULSAR 200 OIL COOLED	08>09	08>09	-	-	N-993	-	N-993C	-	-	-
PULSAR 220 F	10>12	10>12	-	-	N-993	-	N-993C	-	-	-
PULSAR 220 S	11>15	11>15	-	-	N-993	-	N-993C	-	-	-
PULSAR 220 SS	11>16	11>16	-	-	N-993	N-932	N-993C	N-932C	-	-
PULSAR 220 SS PRO	14>16	14>16	-	-	N-993	-	N-993C	-	-	-
PULSAR DOMINAR 400	18>20	18>20	-	-	-	N-932	-	N-932C	-	-
PULSAR NS 125	20>	20>	-	-	N-993	-	N-993C	-	-	-
PULSAR NS 160	18>19	18>19	N-993	-	N-993	-	N-993C	-	-	-
<b>BENELLI</b>										
LEOCINO 500	16>	16>	-	-	N-1804	-	N-1804C	-	-	-
LEOCINO 500	16>	16>	-	-	N-1818	N-1818	N-1818C	N-1818C	-	-
TRK 502	16>	16>	-	-	N-1804	-	N-1804C	-	-	-
TRK 502	16>	16>	-	-	N-1818	N-1818	N-1818C	N-1818C	-	-
<b>BMW</b>										
C 600 SPORT	12>	12>	-	-	N-934	N-932	N-934C	N-932C	-	-
C 650 GT	12>	12>	-	-	N-934	N-932	N-934C	N-932C	-	-
C Evolution	12>	12>	-	-	N-934	N-932	N-934C	N-932C	-	-
C1 125	00>	00>	-	-	N-934	N-1073	N-934C	N-1073C	-	-

B

**Street**

**Racing**

**Racing  
Extreme**

**CUSTOM**

## APLICAÇÃO

Ano



APLICAÇÃO	Ano		Street		Racing		Racing Extreme		CUSTOM	
<b>BMW</b>										
C1 200	02>	02>	N-934	-	N-934	N-1073	N-934C	N-1073C	-	-
F 650 CS SCARVER	02>06	02>06	-	-	N-934	N-932	N-934C	N-932C	-	-
F 650 CS SCARVER	02>	02>	-	-	-	N-1073	-	N-1073C	-	-
F 650 Funduro	94>00	94>00	-	-	N-934	N-932	N-934C	N-932C	-	-
F 650 GS	08>	08>	-	-	N-934	N-932	N-934C	N-932C	-	-
F 650 GS DAKAR	01>07	01>07	-	-	N-934	N-932	N-934C	N-932C	-	-
F 650 GS DAKAR	01>	01>	-	-	-	N-1073	-	N-1073C	-	-
F 650 GS, RALLYE	01>07	01>07	-	-	N-934	N-932	N-934C	N-932C	-	-
F 650 GS/RALLYE	01>	01>	-	-	-	N-1073	-	N-1073C	-	-
F 650 ST, Strada	94>00	94>00	-	-	N-934	N-932	N-934C	N-932C	-	-
F 650 ST/FUNDURO	94>00	94>00	-	-	-	N-1073	-	N-1073C	-	-
F 700 GS	13>	13>	-	-	N-934	N-932	N-934C	N-932C	-	-
F 800 GS	08>	08>	-	-	N-934	N-932	N-934C	N-932C	-	-
F 800 GS	08>	08>	-	-	-	N-1073	-	N-1073C	-	-
F 800 GT	13>	13>	-	-	N-1804	N-932	N-1804C	N-1073C	-	-
F 800 GT	13>	13>	-	-	-	N-1073	-	N-932C	-	-
F 800 R	09>	09>	-	-	N-1804	N-932	N-1804C	N-932C	-	-
F 800 R	09>	09>	-	-	-	N-1073	-	N-1073C	-	-
F 800 S	06>	06>	-	-	N-1804	N-932	N-1804C	N-932C	-	-
F 800 S/ST	06>	06>	-	-	-	N-1073	-	N-1073C	-	-
F 800 ST	06>	06>	-	-	N-1804	N-932	N-1804C	N-932C	-	-
F 800 ST Touring	11>	11>	-	-	N-1804	N-1073	N-1804C	N-932C	-	-
F 800 ST Touring	11>	11>	-	-	-	N-932	-	N-1073C	-	-
G 450 SMR	08>	08>	-	-	N-1811	N-997	N-1811C	N-997C	-	-
G 450 X	08>	08>	-	-	N-993	N-997	N-993C	N-997C	-	-
G 650 Xchallenge	07>	07>	-	-	N-934	N-932	N-934C	N-932C	-	-
G 650 Xcountry	07>	07>	-	-	N-934	N-932	N-934C	N-932C	-	-
G 650 Xmoto	07>	07>	-	-	N-1804	N-932	N-1804C	N-932C	-	-
G 650 GS	09>	09>	-	-	N-934	N-1073	N-934C	N-1073C	-	-
G 650 GS	08>	08>	-	-	-	N-932	-	N-932C	-	-
G 650 GS SERTÃO	12>	12>	-	-	N-934	N-932	N-934C	N-1073C	-	-
G 650 GS SERTÃO	12>	12>	-	-	-	N-1073	-	N-932C	-	-
HP2 1000 SPORT	08>10	08>10	-	-	-	N-993	-	N-993C	-	-
K 1200 LT ABS	01>	01>	-	-	N-1808	-	N-1808C	-	-	-
K 1200 R	05>08	05>08	-	-	N-1808	N-1806	N-1808C	N-1806C	-	-
K 1200 R SPORT	07>	07>	-	-	N-1808	N-1806	N-1808C	N-1806C	-	-
K 1200 RS	01>	01>	-	-	N-1809	-	N-1809C	-	-	-
K 1200 S	05>08	05>08	-	-	N-1809	N-1806	N-1809C	N-1806C	-	-
K 1300 S	05>08	05>08	-	-	N-1809	N-1806	N-1809C	N-1806C	-	-
K 1300 GT	09>10	09>10	-	-	N-1809	N-993	N-1809C	N-993C	-	-
K 1300 R	09>	09>	-	-	N-1808	N-1806	N-1808C	N-1806C	-	-
K 1300 R Dynamic	11>	11>	-	-	N-1808	N-1806	N-1808C	N-1806C	-	-
K 1600 GT	11>	11>	-	-	N-1808	N-934	N-1808C	N-934C	-	-
K 1600 GTL	11>	11>	-	-	N-1808	N-934	N-1808C	N-934C	-	-
R 1100 S	01>	01>	-	-	N-1809	N-1806	N-1809C	N-1806C	-	-
R 1100 S ABS	01>	01>	N-1808	-	N-1809	N-1806	N-1809C	N-1806C	-	-
R 1150 GS	02>	02>	-	-	N-1809	N-1806	N-1809C	N-1806C	-	-
R 1150 GS Adventurer	02>	02>	-	-	N-1809	N-1806	N-1809C	N-1806C	-	-
R 1150 R	01>	01>	-	-	N-1808	N-1806	N-1808C	N-1806C	-	-
R 1150 R Rockster	03>	03>	-	-	N-1808	N-1806	N-1808C	N-1806C	-	-
R 1150 RS	01>	01>	-	-	N-1808	N-1806	N-1808C	N-1806C	-	-
R 1150 RT ABS	01>	01>	-	-	N-1808	N-1806	N-1808C	N-1806C	-	-
R 1200 R	07>	07>	-	-	N-1808	N-1806	N-1808C	N-1806C	-	-
R 1200 R	15>	15>	-	-	N-1790	N-934	N-1790C	N-934C	-	-
R 1200 RT	06>	06>	-	-	N-1809	N-1806	N-1809C	N-1806C	-	-
R 1200 RT	14>	14>	-	-	N-1790	N-934	N-1790C	N-934C	-	-
R 1200 S	06>	06>	-	-	N-1809	N-1806	N-1809C	N-1806C	-	-
R 1200 ST	06>	06>	-	-	N-1809	N-1806	N-1809C	N-1806C	-	-
R 1200 C Classic	03>04	03>04	-	-	N-1808	N-1806	N-1808C	N-1806C	-	-
R 1200 C Independent	03>	03>	-	-	N-1808	N-1806	N-1808C	N-1806C	-	-
R 1200 C Montauk	04>	04>	-	-	N-1808	N-1806	N-1808C	N-1806C	-	-
R 1200 CL	03>	03>	-	-	N-1808	-	N-1808C	-	-	-
R 1200 GS	04>	04>	-	-	N-1809	-	N-1809C	-	-	-
R 1200 GS	13>	13>	-	-	N-1790	N-934	N-1790C	N-934C	-	-
R 1200 GS	13>	04>12	-	-	-	N-1806	-	N-1806C	-	-
R 1200 GS Adventure	14>	14>	-	-	N-1790	N-934	N-1790C	N-934C	-	-

B-C

Street

Racing

Racing  
Extreme

CUSTOM

APLICAÇÃO

Ano



APLICAÇÃO	Ano									
<b>BMW</b>										
R 1200 GS TRIPPLE BLACK	11>	11>	-	-	N-1809	N-1806	N-1809C	N-1806C	-	-
R 1200 Nine-T	14>	14>	-	-	N-1790	N-1790C	-	-	-	-
R 1250 GS	2019>	2019>	-	-	N-934	-	N-934C	-	-	-
R 1250 R HP	2019>	2019>	-	-	N-934	-	N-934C	-	-	-
R 1250 RS	2019>	2019>	-	-	N-934	-	N-934C	-	-	-
R 1250 RT	2019>	2019>	-	-	N-934	-	N-934C	-	-	-
R 850 R	03>	03>	-	-	N-1808	N-1806	N-1808C	N-1806C	-	-
R 850 RT	98>00	98>00	-	-	-	N-1073	-	N-1073C	-	-
R 850 RT ABS	01>	01>	-	-	N-1809	N-1806	N-1809C	N-1806C	-	-
R1250 GS ADVENTURE	2019>	2019>	-	-	N-934	-	N-934C	-	-	-
R1250 GS ADVENTURE PREMIUM	19>	19>	-	-	-	-	N-1892C	-	-	-
R1250 GS ADVENTURE PREMIUM EXCLUSIVE	19>	19>	-	-	-	-	N-1892C	-	-	-
R1250 GS ADVENTURE PREMIUM HP	19>	19>	-	-	-	-	N-1892C	-	-	-
R1250 GS PREMIUM EXCLUSIVE	19>	19>	-	-	-	-	N-1892C	-	-	-
R1250 GS PREMIUM HP	19>	19>	-	-	-	-	N-1892C	-	-	-
R1250 GS SPORT	19>	19>	-	-	-	-	N-1892C	-	-	-
S 1000 R	14>	14>	-	-	N-1810	N-932	N-1810C	N-932C	-	-
S 1000 RR	09>	09>	-	-	N-1810	N-932	N-1810C	N-932C	-	-
S 1000 XR	15>	15>	-	-	N-1790	-	N-1790C	-	-	-
S 1000 R	13>	13>	-	-	-	N-1073	-	N-1073C	-	-
S 1000 RR	09>	09>	-	-	-	N-1073	-	N-1073C	-	-
S 1000 RR HP4	13>	13>	-	-	N-1813	N-1073	N-1813C	N-1073C	-	-
<b>BOMBARDIER</b>										
TRAXTER 500 4X4	99>00	99>00	-	-	N-1818	N-1818	N-1818C	N-1818C	-	-
<b>BRANDY</b>										
FT 125 A FOSTI	-	97>	-	-	-	0321-CP	-	-	-	-
JAGUAR 100	95>	-	-	-	N-1817	-	-	-	-	-
JAGUAR 50	95>	-	-	-	N-1817	-	-	-	-	-
<b>BRANDY / JIALING</b>										
Ankur	89>	-	-	-	0311-CP	-	-	-	-	-
CJ 50, JH 50	92>	92>	-	-	0311-CP	0311-CP	-	-	-	-
Fosti FT 125-A	97>	97>	-	-	N-1013	0307-CP	-	-	-	-
Pacer	89>	-	-	-	0311-CP	-	-	-	-	-
Passing 110	>	>	-	-	N-942	0304-CP	-	-	-	-
<b>BUELL</b>										
XB125 1200 LIGHTNING	04>08	04>08	-	-	-	N-1824	-	N-1824C	-	-
XB125 1200 LIGHTNING LONG	06>08	06>08	-	-	-	N-1824	-	N-1824C	-	-
XB12R 1200 FIREBOLT	04>10	04>10	-	-	-	N-1824	-	N-1824C	-	-
XB12S 1200 CG LIGHTNING	06>10	06>10	-	-	-	N-1824	-	N-1824C	-	-
XB12STT 1200 SUPER TT	07>	07>	-	-	-	N-1824	-	N-1824C	-	-
XB12X 1200 ULYSSES	06>	06>	-	-	-	N-1824	-	N-1824C	-	-
XB9R 984 FIREBOLT	02>	02>	-	-	-	N-1824	-	N-1824C	-	-
XB9S 984 LIGHTNING	03>	03>	-	-	-	N-1824	-	N-1824C	-	-
XB9SX 984 CITY X	05>	05>	-	-	-	N-1824	-	N-1824C	-	-
<b>CAGIVA</b>										
1000 NAVIGATOR/T	00>	00>	-	-	N-930	-	N-930C	-	-	-
1000 RAPTOR/V-RAPTOR	00>	00>	-	-	-	N-1818	-	N-1818C	-	-
ELEFANT 900	93>	93>	-	-	N-993	N-993	N-993C	N-993C	-	-
Gran Canyon	99>	99>	-	-	N-930	-	N-930C	-	-	-
X 1000 RAPTOR	03>	03>	-	-	-	N-1818	-	N-1818C	-	-
X3 1000 RAPTOR	04>	04>	-	-	-	N-1818	-	N-1818C	-	-
Xrta 1000 RAPTOR	02>	02>	-	-	-	N-1818	-	N-1818C	-	-
<b>CALOI</b>										
Mobylete, AV 7 / AV 10	77>	77>	0311-CP	0311-CP	-	-	-	-	-	-
<b>CAN-AM</b>										
COMMANDER 1000	11>14	11>14	-	-	N-1828	N-1828C	-	-	-	-
MAVERICK 1000 XRS	15>	15>	-	-	N-1828	N-1828C	-	-	-	-

D

**Street**

**Racing**

**Racing  
Extreme**

**CUSTOM**

### APLICAÇÃO

Ano



APLICAÇÃO	Ano									
<b>DAELIM</b>										
ALTINO 100	98>	98>	-	-	N-906	0304-CP	-	-	-	-
DX 50 D Camper	03>	-	-	-	N-1817	-	-	-	-	-
M 50 D/MD Millenium	03>	-	-	-	N-1817	-	-	-	-	-
ROADWIN 250	2017>	2017>	-	-	N-930	N-930C	-	-	-	-
ST 90 Pro Monkey	03>	-	-	-	N-1817	-	-	-	-	-
VF 125	95>	-	-	-	N-906	-	-	-	-	-
VT 125 MAGNA	97>	-	-	-	N-915	-	-	-	-	-
<b>DAFRA</b>										
Apache 150	10>	10>	-	-	N-942	0321-CP	-	-	-	-
APACHE RTR 150	10>	10>	-	-	N-1826	N-1826C	-	-	-	-
CITYCLASS i 200	-	15>	-	-	-	N-919	-	-	-	-
Citycom 300 I	10>	-	-	-	N-1800	N-1800	-	-	-	-
HORIZON 150	08>	08>	-	-	N-970	N-1826	N-970C	N-1826C	-	-
Horizon 250	13>	08>	-	-	N-915	N-940	-	-	-	-
Kansas 150	08>	08>	-	-	N-1828	-	N-1828C	-	-	-
Kansas 150	08>	-	-	-	N-942	-	-	-	-	-
Kansas 250	09>	09>	-	-	N-970	N-1826	N-970C	N-1826C	-	-
Kansas 250	-	09>	-	-	-	N-940	-	-	-	-
Lazer 150	08>	08>	-	-	N-941	0301-CP	-	-	-	-
Next 250	12>	12>	-	-	N-1819	N-1820	-	-	-	-
Riva 150	11>	-	-	-	N-940	-	-	-	-	-
Roadwin 250	11>	11>	-	-	N-1819	N-1820	-	-	-	-
Smart Joy 125	12>	12>	-	-	N-947	0304-CP	-	-	-	-
Smart 125	09>	09>	-	-	N-947	0304-CP	-	-	-	-
Speed 150	08>	-	-	-	N-906	-	-	-	-	-
Speed 150 Cargo	11>	-	-	-	N-906	-	-	-	-	-
Super 100	08>	08>	-	-	0304-CP	0320-CP	-	-	-	-
Super 50	08>	08>	-	-	0304-CP	0304-CP	-	-	-	-
Zig 100	09>	09>	-	-	N-954	0308-CP	-	-	-	-
Zig + 100	09>	09>	-	-	N-954	0308-CP	-	-	-	-
Zig 50	11>	11>	-	-	0304-CP	0304-CP	-	-	-	-
<b>DAYUN</b>										
110-6	08>	08>	-	-	N-940	0304-CP	-	-	-	-
125-8	08>	08>	-	-	N-1013	0302-CP	-	-	-	-
150-7	08>	-	-	-	N-1013	-	-	-	-	-
250-2	08>	-	-	-	N-911	-	-	-	-	-
250-2	08>	08>	-	-	N-940	N-911	-	-	-	-
GY 150 CROSS	08>	-	-	-	N-941	-	-	-	-	-
GY 150 CROSS	08>	08>	-	-	N-954	N-941	-	-	-	-
<b>DUCATI</b>										
848	08>10	08>10	-	-	N-1804	N-1818	N-1804C	N-1818C	-	-
749 R (Rad.cal)	04>	04>	-	-	N-1811	N-1818	N-1811C	N-1818C	-	-
749, S	03>	03>	-	-	N-1811	N-1818	N-1811C	N-1818C	-	-
848 EVO	11>	11>	-	-	N-1813	N-1818	N-1813C	N-1818C	-	-
Biposto 1000	07>	07>	-	-	N-934	N-932	N-934C	N-932C	-	-
Desmosedici 990 RR D16RR	07>	07>	-	-	N-1813	N-1818	N-1813C	N-1818C	-	-
Diavel 1200	11>	11>	-	-	N-1813	N-934	N-1813C	N-934C	-	-
Diavel Strada 1200	13>	13>	-	-	N-1813	N-934	N-1813C	N-934C	-	-
GT 1000	05>	05>	-	-	N-934	N-1818	N-934C	N-1818C	-	-
GT 1000	05>	05>	-	-	-	N-932	-	N-932C	-	-
GT 1000 Touring	09>	09>	-	-	N-934	N-932	N-934C	N-932C	-	-
Hypermotard EVO SP 1100	10>	10>	-	-	N-1813	N-1818	N-1813C	N-1818C	-	-
Hypermotard EVO 1100	10>	10>	-	-	N-1804	N-1818	N-1804C	N-1818C	-	-
Hypermotard 1000	06	06	-	-	N-1811	N-1818	N-1811C	N-1818C	-	-
Hypermotard 1100	07>	07>	-	-	N-1813	N-1818	N-1813C	N-1818C	-	-
Hypermotard 796	10>	10>	-	-	N-1804	N-1818	N-1804C	N-1818C	-	-
Hypermotard 800, SP	13>	13>	-	-	-	N-1818	-	N-1818C	-	-
Hypermotard 939	16>	16>	-	-	N-1790	N-1818	N-1790C	N-1818C	-	-
Hypermotard 939, SP	16>	16>	-	-	N-1790	N-1818	N-1790C	N-1818C	-	-
Hyperstrada	16>	16>	-	-	N-1790	-	N-1790C	-	-	-
Monster 1200	14>	14>	-	-	-	N-1818	-	N-1818C	-	-
Monster 1200 S	14>	14>	-	-	N-1813	N-1818	N-1813C	N-1818C	-	-
Monster EVO 1100	11>	11>	-	-	N-1804	N-1818	N-1804C	N-1818C	-	-

D

Street

Racing

Racing  
Extreme

CUSTOM

APLICAÇÃO

Ano



APLICAÇÃO	Ano									
<b>DUCATI</b>										
Monster 1000 S2R	06>	06>	-	-	N-1804	N-1818	N-1804C	N-1818C	-	-
Monster 1000, Dark	03>	03>	-	-	N-1804	-	N-1804C	-	-	-
Monster 1100	09>	09>	-	-	N-1804	N-1818	N-1804C	N-1818C	-	-
Monster 400 Dark	00>06	00>06	-	-	N-1804	-	N-1804C	-	-	-
Monster 600	94>99	94>99	-	-	N-1804	-	N-1804C	-	-	-
Monster 620	02>	02>	-	-	N-1804	-	N-1804C	-	-	-
Monster 695	07>	07>	-	-	N-934	-	N-934C	-	-	-
Monster 696	08>	08>	-	-	N-1804	N-1818	N-1804C	N-1818C	-	-
Monster 750, ie	00>02	00>02	-	-	N-1804	-	N-1804C	-	-	-
Monster 796	10>	10>	-	-	N-1804	N-1818	N-1804C	N-1818C	-	-
MONSTER 796	12>	12>	-	-	-	N-1818	-	N-1818C	-	-
Monster 800 i.e, s i.e.	03>	03>	-	-	N-1804	-	N-1804C	-	-	-
MONSTER 800 S2R	05>	05>	-	-	N-993	-	N-993C	-	-	-
Monster 821	15>	15>	-	-	N-1790	N-1818	N-1790C	N-1818C	-	-
Monster 821 Dark	15>	15>	-	-	N-1790	N-1818	N-1790C	N-1818C	-	-
Monster 900, ie	00>02	00>02	-	-	N-1804	-	N-1804C	-	-	-
Monster 916 S4	01>03	01>03	-	-	N-1804	-	N-1804C	-	-	-
Monster 999 S4RS, S4R	07>	07>	-	-	N-1811	N-1818	N-1811C	N-1818C	-	-
Monster S 1100	09>	09>	-	-	N-1804	N-1818	N-1804C	N-1818C	-	-
Monster S4R 996	04>	04>	-	-	N-1804	-	N-1804C	-	-	-
Multistrada 1000	07>	07>	-	-	N-1804	N-1818	N-1804C	N-1818C	-	-
Multistrada 1000 DS	03>06	03>06	-	-	N-1804	N-1818	N-1804C	N-1818C	-	-
Multistrada 1000 S DS	05>	05>	-	-	N-1804	N-1818	N-1804C	N-1818C	-	-
Multistrada 1200	10>	10>	-	-	N-1804	N-1818	N-1804C	N-1818C	-	-
Multistrada 1200	15>	15>	-	-	N-1790	-	N-1790C	-	-	-
Multistrada 1200 Enduro	16>	16>	-	-	N-1790	-	N-1790C	-	-	-
MULTISTRADA 1200 S	15>	15>	-	-	-	N-993	-	N-993C	-	-
Multistrada 1200 S GT	13>	13>	-	-	N-1804	N-1818	N-1804C	N-1818C	-	-
Multistrada 1200 S Pikes Peak	11>	11>	-	-	N-1804	N-1818	N-1804C	N-1818C	-	-
Multistrada 1200 S Sport	10>	10>	-	-	N-1804	N-1818	N-1804C	N-1818C	-	-
Multistrada 1200 S Tauring	10>	10>	-	-	N-1804	N-1818	N-1804C	N-1818C	-	-
MULTISTRADA 620	05>	05>	-	-	N-993	-	N-993C	-	-	-
Multistrada Dark 620	05>	05>	-	-	N-1804	N-1818	N-1804C	N-1818C	-	-
Panigale 1199	12>	12>	-	-	N-1813	N-1818	N-1813C	N-1818C	-	-
Panigale 899	14>15	14>15	-	-	N-1790	N-1818	N-1790C	N-1818C	-	-
Panigale 959	16>	16>	-	-	N-1790	N-1818	N-1790C	N-1818C	-	-
Panigale R 1199	13>	13>	-	-	N-1813	N-1818	N-1813C	N-1818C	-	-
Panigale S 1199	12>	12>	-	-	N-1813	N-1818	N-1813C	N-1818C	-	-
PANIGALE/PANIGALE S 1299	15>	15>	-	-	-	N-1818	-	N-1818C	-	-
Paul Smart 1000	05>	05>	-	-	N-934	N-932	N-934C	N-932C	-	-
Paul Smart 1000	05>	05>	-	-	-	N-1818	-	N-1818C	-	-
R 1098	08>	08>	-	-	N-1813	N-1818	N-1813C	N-1818C	-	-
R 999	08>	08>	-	-	N-1811	N-1818	N-1811C	N-1818C	-	-
S 1098	07>08	07>08	-	-	N-1813	N-1818	N-1813C	N-1818C	-	-
S 1198	09>	09>	-	-	N-1813	N-1818	N-1813C	N-1818C	-	-
S 998	.02	.02	-	-	N-1804	-	N-1804C	-	-	-
S 999	03>	03>	-	-	N-1811	N-1818	N-1811C	N-1818C	-	-
S, SP, R 748	98>02	98>02	-	-	N-1804	-	N-1804C	-	-	-
SCRAMBLER 800	15>18	15>18	-	-	-	N-932	-	N-932C	-	-
Scrambler 800 Classic	15>	15>	-	-	N-1790	-	N-1790C	-	-	-
Scrambler 800 Full Throttle	15>	15>	-	-	N-1790	-	N-1790C	-	-	-
Scrambler 800 Icon	15>	15>	-	-	N-1790	-	N-1790C	-	-	-
Scrambler 800 Urbam Enduro	16>	16>	-	-	N-1790	-	N-1790C	-	-	-
SP 1198	12>	12>	-	-	N-1813	N-1818	N-1813C	N-1818C	-	-
Sport / Supersport 750	98>02	00>	-	-	N-1804	N-1818	N-1804C	N-1818C	-	-
Sport 1000	05>	05>	-	-	N-934	N-932	N-934C	N-932C	-	-
SPORT 620	03>	03>	-	-	-	N-1818	-	N-1818C	-	-
Sport Touring 916	99>01	99>01	-	-	N-1804	N-1818	N-1804C	N-1818C	-	-
Sport Touring 944	98>	98>	-	-	N-1804	N-1818	N-1804C	N-1818C	-	-
SPS 916	97>98	97>98	-	-	N-1804	-	N-1804C	-	-	-
SPS 996	99>01	99>01	-	-	N-1804	-	N-1804C	-	-	-
ST2 944	97>03	97>03	-	-	N-1804	N-1818	N-1804C	N-1818C	-	-
ST3 992	04>07	04>07	-	-	N-1804	N-1818	N-1804C	N-1818C	-	-
ST3S 992 (C / ABS)	06>	06>	-	-	N-1804	N-1818	N-1804C	N-1818C	-	-
ST4 916	99>02	99>02	-	-	N-1804	-	N-1804C	-	-	-
ST4S 996	02>	02>	-	-	N-1804	N-1818	N-1804C	N-1818C	-	-

D-F-G-H

**Street**

**Racing**

**Racing  
Extreme**

**CUSTOM**

## APLICAÇÃO

Ano



APLICAÇÃO	Ano		Street		Racing		Racing Extreme		CUSTOM	
<b>DUCATI</b>										
ST4S 996 ABS	03>	03>	-	-	N-1804	N-1818	N-1804C	N-1818C	-	-
Streetfighter 1098	09>	09>	-	-	N-1813	N-1818	N-1813C	N-1818C	-	-
Streetfighter 848	11>	11>	-	-	N-1804	N-1818	N-1804C	N-1818C	-	-
Streetfighter S 1098	09>	09>	-	-	N-1813	N-1818	N-1813C	N-1818C	-	-
Streetfighter S 848	12>	12>	-	-	N-1813	N-1818	N-1813C	N-1818C	-	-
Superleggera 1199	14>	14>	-	-	N-1813	N-1818	N-1813C	N-1818C	-	-
Supersport 1000	03>	03>	-	-	N-1804	N-1818	N-1804C	N-1818C	-	-
Supersport 800	03>	03>	-	-	N-1804	N-1818	N-1804C	N-1818C	-	-
Supersport 900	98>	98>	-	-	N-1804	N-1818	N-1804C	N-1818C	-	-
<b>FYM</b>										
FY-10A 100	-	07>	-	0304-CP	-	-	-	-	-	-
FY-19 125	06>	06>	N-1013	0321-CP	-	-	-	-	-	-
<b>GAS GAS</b>										
EC 125	97>99	97>99	-	-	N-993	N-1073	N-993C	N-1073C	-	-
EC 125	00>	00>	-	-	N-991	N-1075	N-991C	N-1075C	-	-
EC 200	99	99	-	-	N-993	N-1073	N-993C	N-1073C	-	-
EC 200	00>	00>	-	-	N-991	N-1075	N-991C	N-1075C	-	-
EC 250	97>99	97>99	-	-	N-993	N-1073	N-993C	N-1073C	-	-
EC 250	00>11	00>11	-	-	N-991	N-1075	N-991C	N-1075C	-	-
EC 250	12>	12>	-	-	N-991	N-1011	N-991C	N-1011C	-	-
EC 250 FSE	02>	02>	-	-	N-991	N-1075	N-991C	N-1075C	-	-
EC 300	99	99	-	-	N-993	N-1073	N-993C	N-1073C	-	-
EC 300	00>11	00>11	-	-	N-991	N-1075	N-991C	N-1075C	-	-
EC 300	12>	12>	-	-	N-991	-	N-991C	N-1011C	-	-
EC 400 FSE	02	02	-	-	N-991	N-1075	N-991C	N-1075C	-	-
EC 450 FSE	03>	03>	-	-	N-991	N-1075	N-991C	N-1075C	-	-
EC 450 FSR	07>	07>	-	-	N-991	N-1075	N-991C	N-1075C	-	-
MC 125	03>	03>	-	-	N-991	N-1075	N-991C	N-1075C	-	-
MC 250	97>99	97>99	-	-	N-993	N-1073	N-993C	N-1073C	-	-
MC 250	00>	00>	-	-	N-991	N-1075	N-991C	N-1075C	-	-
SM 125 / 250	02>	02>	-	-	-	N-1075	-	N-1075C	-	-
SM 400	03>	03>	-	-	-	N-1075	-	N-1075C	-	-
SM 450 FSE / FSR	03>	03>	-	-	-	N-1075	-	N-1075C	-	-
WILD 240 HP	04>	04>	-	-	N-993	N-993	N-993C	N-993C	-	-
WILD 450 HP	03>	03>	-	-	N-993	N-993	N-993C	N-993C	-	-
<b>GILERA</b>										
FU 110	05>	-	N-941	-	-	-	-	-	-	-
SMASH 110	05>	-	N-941	-	-	-	-	-	-	-
<b>GUERRERO</b>										
FLASH 110	05>	-	N-941	-	-	-	-	-	-	-
TRIP 110	05>	-	N-941	-	-	-	-	-	-	-
<b>HAOJUE</b>										
TZ 150	18>	-	N-942	-	-	-	-	-	-	-
DK 150	2018>	-	N-1889	-	-	-	-	-	-	-
<b>HARLEY-DAVIDSON</b>										
1340 DYNA GLIDE STURGIS	91>	-	-	-	-	-	-	-	N-1603	-
1690 SOFTAIL DELUXE	12>	-	-	-	-	-	-	-	N-1609	-
FL 1200 FHL Police	75>79	75>79	-	-	-	-	-	-	N-1602	N-1602
FLD 1690 Switchback	12>	12>	-	-	-	-	-	-	N-1609	N-1613
FLH 1200	80	-	-	-	-	-	-	-	N-1602	-
FLH 1200	74>76	74>76	-	-	-	-	-	-	N-1602	N-1602
FLH 1200 Anniversary	78	78	-	-	-	-	-	-	N-1602	N-1602
FLH 1200 Touring	77>78	77>78	-	-	-	-	-	-	N-1602	N-1602
FLH 1340 80	81	-	-	-	-	-	-	-	N-1602	-
FLH 1340 80	78>80	78>80	-	-	-	-	-	-	N-1602	N-1602
FLH 1340 Electra Glide	-	82>83	-	-	-	-	-	-	-	N-1602
FLH 1340 Electra Glide Spec.	84	-	-	-	-	-	-	-	N-1602	-
FLHR 1584 Road King	07	07	-	-	-	-	-	-	N-1600	N-1600
FLHR 1584 Road King	08>	08>	-	-	-	-	-	-	N-1611	N-1611
FLHR 1690 Road King	11>	11>	-	-	-	-	-	-	N-1611	N-1611

H

Street

Racing

Racing  
Extreme

CUSTOM

APLICAÇÃO

Ano



APLICAÇÃO	Ano								
<b>HARLEY-DAVIDSON</b>									
FLHR/I 1450 Road King*	00>06	00>06	-	-	-	-	-	-	N-1600 N-1600
FLHRC 1584 Road King Classic	07	07	-	-	-	-	-	-	N-1600 N-1600
FLHRC 1584 Road King Classic	08>	08>	-	-	-	-	-	-	N-1611 N-1611
FLHRC 1690 Road King Classic	11>	11>	-	-	-	-	-	-	N-1609 N-1613
FLHRCI 1450 Road King Classic	00>06	00>06	-	-	-	-	-	-	N-1600 N-1600
FLHRS 1584 Road King Custom	07>	07>	-	-	-	-	-	-	N-1600 N-1600
FLHRS/I 1450 Road King Custom	00>06	00>06	-	-	-	-	-	-	N-1600 N-1600
FLHRSE5 1802 CVO Road King	14>	14>	-	-	-	-	-	-	N-1600 N-1600
FLHS 1200	77>80	77>80	-	-	-	-	-	-	N-1602 N-1602
FLHS 1340 Electra Glide Sport	90	90	-	-	-	-	-	-	N-1603 N-1606
FLHT 1340 Electra Glide	85>86	-	-	-	-	-	-	-	N-1603 -
FLHT 1340 Electra Glide Classic	87>99	87>99	-	-	-	-	-	-	N-1603 N-1605
FLHT 1584 Electra Glide Standard	07	07	-	-	-	-	-	-	N-1600 N-1600
FLHT 1584 Electra Glide Standard	08>	08>	-	-	-	-	-	-	N-1611 N-1611
FLHT/I 1450 Electra Glide Standard	00>06	00>06	-	-	-	-	-	-	N-1600 N-1600
FLHTC 1340 Electra Glide Classic	93	93	-	-	-	-	-	-	N-1603 N-1605
FLHTC 1340 Electra Glide Classic	85>86	-	-	-	-	-	-	-	N-1603 -
FLHTC 1340 Electra Glide Classic	90>99	90>99	-	-	-	-	-	-	N-1603 N-1606
FLHTC 1340 Ultra Classic	90>99	90>99	-	-	-	-	-	-	N-1603 N-1606
FLHTC 1584 Electra Glide	08>	08>	-	-	-	-	-	-	N-1611 N-1611
FLHTC 1584 Electra Glide Classic	07	07	-	-	-	-	-	-	N-1600 N-1600
FLHTC 1584 Electra Glide Classic	08>	08>	-	-	-	-	-	-	N-1611 N-1611
FLHTC 1690 Electra Glide Classic	11>	11>	-	-	-	-	-	-	N-1609 N-1613
FLHTC/I 1450 Electra Glide Classic	00>06	00>06	-	-	-	-	-	-	N-1600 N-1600
FLHTCI 1584 Ultra Classic Electra Glide	08>	08>	-	-	-	-	-	-	N-1611 N-1611
FLHTCU 1584 Ultra Classic Electra Glide	07>10	07>10	-	-	-	-	-	-	N-1600 N-1600
FLHTCU 1690 Ultra Classic Electra Glide	11>	11>	-	-	-	-	-	-	N-1611 N-1611
FLHTCUI 1450 Ultra Classic Electra Glide	00>06	00>06	-	-	-	-	-	-	N-1600 N-1600
FLHTK 1584 Electra Gilde Ultra LTD	10>	10>	-	-	-	-	-	-	N-1611 N-1611
FLHTK 1690 Electra Glide Ultra	11>	11>	-	-	-	-	-	-	N-1609 N-1613
FLHTK 1690 Ultra Classic Electra Glide	10>	10>	-	-	-	-	-	-	N-1611 N-1611
FLHTKSE 1802 CVO Limited	14>	14>	-	-	-	-	-	-	N-1600 N-1600
FLHX 1584 Street Glide	07	07	-	-	-	-	-	-	N-1600 N-1600
FLHX 1584 Street Glide	08>	08>	-	-	-	-	-	-	N-1611 N-1611
FLHX 1690 Street Glide	11>	11>	-	-	-	-	-	-	N-1611 N-1611
FLHXI 1450 Street Glide	06	-	-	-	-	-	-	-	N-1600 -
FLHXI 1450 Street Glide	-	06	-	-	-	-	-	-	- N-1600
FLHXS 1690 Street Glide Special	14>	14>	-	-	-	-	-	-	N-1611 N-1611
FLHXXX 1690 Street Glide Trike	10>	10>	-	-	-	-	-	-	N-1611 N-1611
FLS 1584 Softail Slim	-	12>	-	-	-	-	-	-	- N-1613
FLSS 1802 SOFTAIL SLIM S	-	16>	-	-	-	-	-	-	- N-1613
FLST 1340 Heritage Softail	86>87	-	-	-	-	-	-	-	N-1603 -
FLST 1340 Heritage Softail	88>99	88>99	-	-	-	-	-	-	N-1603 N-1606
FLST 1340 Heritage Softail Cl.	90>99	90>99	-	-	-	-	-	-	N-1603 N-1605
FLST 1340 Heritage Softail Nost.	93>99	93>99	-	-	-	-	-	-	N-1603 N-1605
FLSTC 1450 Softail	06>07	06>07	-	-	-	-	-	-	N-1600 N-1600
FLSTC 1584 Heritage Softail Classic	07	-	-	-	-	-	-	-	N-1600 -
FLSTC 1584 Heritage Softail Classic	08>	08>	-	-	-	-	-	-	N-1609 N-1613
FLSTC 1584 SOFTAIL DELUXE	-	08>	-	-	-	-	-	-	- N-1613
FLSTC/I 1450 Heritage Softail Classic	00>04	00>04	-	-	-	-	-	-	N-1600 N-1600
FLSTCI 1450 Softail	06	06	-	-	-	-	-	-	N-1600 N-1600
FLSTF 1340 Fat Boy	90>99	90>99	-	-	-	-	-	-	N-1603 N-1605
FLSTF 1450 Fat Boy	06>07	06>07	-	-	-	-	-	-	N-1600 N-1600
FLSTF 1584 Fat Boy	07>07	-	-	-	-	-	-	-	N-1600 -
FLSTF 1584 Fat Boy	08>	08>	-	-	-	-	-	-	N-1609 N-1613
FLSTF 1690 Fat Boy	12>	12>	-	-	-	-	-	-	N-1609 N-1613
FLSTF 1690 Fat Boy Special	12>	12>	-	-	-	-	-	-	N-1609 N-1613
FLSTF/I 1450 Fat Boy	00>04	00>04	-	-	-	-	-	-	N-1600 N-1600
FLSTFB 1584 Fat Boy Special	10>	10>	-	-	-	-	-	-	N-1609 N-1613
FLSTFI 1450 Fat Boy	06	06	-	-	-	-	-	-	N-1600 N-1600
FLSTI 1450 Heritage Softail	06	-	-	-	-	-	-	-	N-1600 -
FLSTN 1584 Softail Deluxe	07	-	-	-	-	-	-	-	N-1600 -
FLSTN 1584 Softail Deluxe	08>	08>	-	-	-	-	-	-	N-1609 N-1613
FLSTN 1690 Softail Deluxe	12>	12>	-	-	-	-	-	-	N-1609 N-1613
FLSTN/I 1450 Heritage Springer	00>03	00>03	-	-	-	-	-	-	N-1603 N-1600
FLSTN/I 1450 Softail Deluxe	06	06	-	-	-	-	-	-	N-1600 N-1600

H

**Street**

**Racing**

**Racing  
Extreme**

**CUSTOM**

### APLICAÇÃO

Ano



APLICAÇÃO	Ano		Street		Racing		Racing Extreme		CUSTOM	
<b>HARLEY-DAVIDSON</b>										
FLSTNSE 1802 CVO Softail Deluxe	14>	-	-	-	-	-	-	-	N-1609	-
FLSTNSE 1802 CVO Softail Deluxe	14>	14>	-	-	-	-	-	-	N-1600	N-1600
FLSTNSE 1802 CVO SOFTAIL DELUXE	-	15>	-	-	-	-	-	-	-	N-1613
FLSTS 1584 FAT BOY	-	08>	-	-	-	-	-	-	-	N-1613
FLSTSCI/1 1450 Springer Softail Classic	06	06	-	-	-	-	-	-	N-1603	N-1600
FLSTSCI/1 1584 Softail	07	-	-	-	-	-	-	-	N-1603	-
FLSTSCI 1450 SPRINGER SOFTAIL CLASSIC	-	05>	-	-	-	-	-	-	-	N-1600
FLT 1340	84>85	84>85	-	-	-	-	-	-	N-1603	N-1605
FLT Series	88>99	88>99	-	-	-	-	-	-	N-1603	N-1606
FLT/H Series	86>87	86>87	-	-	-	-	-	-	N-1603	N-1606
FLTC 1340 Tour Gilde Classic	90	90	-	-	-	-	-	-	N-1603	N-1606
FLTC 1340 Tour Gilde Classic	85>86	-	-	-	-	-	-	-	N-1603	-
FLTFBS 1802 FAT BOY S	-	16>	-	-	-	-	-	-	-	N-1613
FLTR 1584 Road Glide	08>	08>	-	-	-	-	-	-	N-1611	N-1611
FLTR/1 1450 Road Glide Classic	00>06	00>06	-	-	-	-	-	-	N-1600	N-1600
FLTRCUTG 1690 Tri Glide Ultra Classic Trike	09>	09>	-	-	-	-	-	-	N-1611	N-1611
FLTRU 1584 Road Glide Ultra	11>	11>	-	-	-	-	-	-	N-1611	N-1611
FLTRX 1584 Road Glide Custom	10>	10>	-	-	-	-	-	-	N-1611	N-1611
FX 1200	-	74>80	-	-	-	-	-	-	-	N-1602
FXB 1340 80	-	80>81	-	-	-	-	-	-	-	N-1602
FXB 1340 Sturgis	-	82	-	-	-	-	-	-	-	N-1602
FXCW 1584 Rocker	08>	08>	-	-	-	-	-	-	N-1609	N-1613
FXCWC 1584 Rocker C	08>	08>	-	-	-	-	-	-	N-1609	N-1613
FXD 1450 Dyna Super Glide	00>06	00>06	-	-	-	-	-	-	N-1600	N-1600
FXD 1584 Dyna Super Glide	07	07	-	-	-	-	-	-	N-1600	N-1600
FXD 1584 Dyna Super Glide	08>	08>	-	-	-	-	-	-	N-1609	N-1613
FXD 1584 Dyna Super Glide Custom	08>	08>	-	-	-	-	-	-	N-1609	N-1613
FXDB 1340 Dyna Glide Daytona	91>99	91>99	-	-	-	-	-	-	N-1603	N-1605
FXDB 1340 Dyna Glide Sturgis	91>99	91>99	-	-	-	-	-	-	N-1603	N-1605
FXDB 1340 Dyna Low Rider	93>99	93>99	-	-	-	-	-	-	N-1603	N-1605
FXDB 1340 Sturgis	91>99	91>99	-	-	-	-	-	-	N-1603	N-1605
FXDB 1450 Dyna Street Bob	08>	08>	-	-	-	-	-	-	N-1609	N-1613
FXDB 1584 Dyna Street Bob	07	07	-	-	-	-	-	-	N-1600	N-1600
FXDB 1584 Dyna Street Bob	08>13	08>13	-	-	-	-	-	-	N-1609	N-1613
FXDB 1690 Dyna Street Bob	14>	14>	-	-	-	-	-	-	N-1609	N-1613
FXDBI 1450 Dyna Street Bob	06	06	-	-	-	-	-	-	N-1600	N-1600
FXDC 1584 Dyna Super Glide Custom	07	07	-	-	-	-	-	-	N-1600	N-1600
FXDC 1584 Dyna Super Glide Custom	08>	08>	-	-	-	-	-	-	N-1609	N-1613
FXDC 1690 Dyna Super Glide Custom	14>	14>	-	-	-	-	-	-	N-1609	N-1613
FXDC/1 1450 Dyna Super Glide Custom	05>06	05>06	-	-	-	-	-	-	N-1600	N-1600
FXDF 1584 Fat Bob	08>	08>	-	-	-	-	-	-	N-1609	N-1613
FXDI 1450 35th Anniversary Super Gilde	06	-	-	-	-	-	-	-	N-1600	-
FXDI 1450 Dyna Super Glide	04	04	-	-	-	-	-	-	N-1600	N-1600
FXDI 1450 Dyna Super Glide	05>06	05>06	-	-	-	-	-	-	N-1600	N-1600
FXDL 1450 Dyna Low Rider	00>03	00>03	-	-	-	-	-	-	N-1600	N-1600
FXDL 1584 Dyna Low Rider	07	07	-	-	-	-	-	-	N-1600	N-1600
FXDL 1584 Dyna Low Rider	08>	08>	-	-	-	-	-	-	N-1609	N-1613
FXDLI 1450 Dyna Low Rider	04>06	04>06	-	-	-	-	-	-	N-1600	N-1600
FXDS 1450 Dyna Convertible	00>02	00>02	-	-	-	-	-	-	N-1600	N-1600
FXDWG 1340 Dyna Wide Glide	93>99	93>99	-	-	-	-	-	-	N-1603	N-1605
FXDWG 1450 Dyna Wide Glide	00>03	00>03	-	-	-	-	-	-	N-1600	N-1600
FXDWG 1584 Dyna Wide Glide	07	07	-	-	-	-	-	-	N-1600	N-1600
FXDWG 1584 Dyna Wide Glide	08>	08>	-	-	-	-	-	-	N-1609	N-1613
FXDWGI 1450 Dyna Wide Glide	04>06	04>06	-	-	-	-	-	-	N-1600	N-1600
FXDX 1450 Dyna Super Glide Sport	00>03	00>03	-	-	-	-	-	-	N-1600	N-1600
FXDXI 1450 Dyna Super Glide Sport	04>06	04>06	-	-	-	-	-	-	N-1600	N-1600
FXDXT 1450 Dyna Super Glide T-Sport	00>03	00>03	-	-	-	-	-	-	N-1600	N-1600
FXE 1200	-	74>80	-	-	-	-	-	-	-	N-1602
FXE 1340	85>88	82	-	-	-	-	-	-	N-1603	N-1605
FXE 1340 80	-	78>81	-	-	-	-	-	-	-	N-1602
FXE 1340 Super Gilde	-	83>84	-	-	-	-	-	-	-	N-1602
FXE 80 Fat Bob	-	79>81	-	-	-	-	-	-	-	N-1602
FXLR 1340 Low Rider Custom	87>88	87>88	-	-	-	-	-	-	N-1603	N-1605
FXLR 1340 Low Rider Custom	93>99	93>99	-	-	-	-	-	-	N-1603	N-1605
FXR 1340	87>88	87>88	-	-	-	-	-	-	N-1603	N-1605
FXR 1340	-	78>81	-	-	-	-	-	-	-	N-1602

H

Street

Racing

Racing  
Extreme

CUSTOM

APLICAÇÃO

Ano



APLICAÇÃO	Ano		Street		Racing		Racing Extreme		CUSTOM	
<b>HARLEY-DAVIDSON</b>										
FXR 1340 Super Glide	85>86	-	-	-	-	-	-	-	N-1603	-
FXR 1340 Super Glide	90>99	90>99	-	-	-	-	-	-	N-1603	N-1605
FXRD 1340 Sport Glide GTE	85>86	-	-	-	-	-	-	-	N-1603	-
FXRS 1340 Low Rider	85>86	-	-	-	-	-	-	-	N-1603	-
FXRS 1340 Low Rider Sport	87>99	87>99	-	-	-	-	-	-	N-1603	N-1605
FXRS 1340 Low Rider Sport Ed.	90>99	90>99	-	-	-	-	-	-	N-1603	N-1605
FXRS 1340 Low Rider, Convert.	90>99	90>99	-	-	-	-	-	-	N-1603	N-1605
FXRT 1340 Sport Glide	85>86	-	-	-	-	-	-	-	N-1603	-
FXRT 1340 Sport Glide	90>99	90>99	-	-	-	-	-	-	N-1603	N-1605
FXS 1200	-	78>79	-	-	-	-	-	-	-	N-1602
FXS 1340 80	-	79>81	-	-	-	-	-	-	-	N-1602
FXS 1340 Low Rider	-	82	-	-	-	-	-	-	-	N-1602
FXS 1584 Softail Blackline	-	11>	-	-	-	-	-	-	-	N-1613
FXS 1690 Blackline	13>	13>	-	-	-	-	-	-	N-1609	N-1613
FXSB 1690 BREAKOUT	-	15>	-	-	-	-	-	-	-	N-1613
FXSBSE 1802 CVO Breakout	13>	13>	-	-	-	-	-	-	N-1609	N-1613
FXST 1340 Softail	84>86	-	-	-	-	-	-	-	N-1603	-
FXST 1584 Softail Custom	07	07	-	-	-	-	-	-	N-1600	N-1600
FXST 1584 Softail Custom	08>	08>	-	-	-	-	-	-	N-1609	N-1613
FXST 1584 Softail Standard	07	07	-	-	-	-	-	-	N-1600	N-1600
FXST 1584 Softail Standard	08>	08>	-	-	-	-	-	-	N-1609	N-1613
FXST/I 1450 Softail Standard	06	-	-	-	-	-	-	-	N-1600	-
FXST/I 1450 Softail Standard	00>05	00>05	-	-	-	-	-	-	N-1600	N-1600
FXSTB 1584 Night Train	07	07	-	-	-	-	-	-	N-1600	N-1600
FXSTB 1584 Night Train	08>	08>	-	-	-	-	-	-	N-1609	N-1613
FXSTB/I 1450 Night Train	06	-	-	-	-	-	-	-	N-1600	-
FXSTB/I 1450 Night Train	00>05	00>05	-	-	-	-	-	-	N-1600	N-1600
FXSTC 1340 Softail Custom	85>86	-	-	-	-	-	-	-	N-1603	-
FXSTC 1340 Softail Custom	88>99	88>99	-	-	-	-	-	-	N-1603	N-1605
FXSTD 1584 Softail Deluxe	07	07	-	-	-	-	-	-	N-1600	N-1600
FXSTD 1584 Softail Deuce	07	07	-	-	-	-	-	-	N-1600	N-1600
FXSTD/I 1450 Softail Deluxe	06	06	-	-	-	-	-	-	N-1600	N-1600
FXSTD/I 1450 Softail Deuce	06	-	-	-	-	-	-	-	N-1600	-
FXSTD/I 1450 Softail Deuce	00>05	00>05	-	-	-	-	-	-	N-1600	N-1600
FXSTS 1340 Springer Softail	90>99	90>99	-	-	-	-	-	-	N-1603	N-1605
FXSTS/I 1450 Softail	05	05	-	-	-	-	-	-	N-1603	N-1600
FXSTS/I 1450 Springer Softail	00>04	00>04	-	-	-	-	-	-	N-1603	N-1600
FXWG 1340	87>88	87>88	-	-	-	-	-	-	N-1603	N-1605
FXWG 1340 80	-	80>81	-	-	-	-	-	-	-	N-1602
FXWG 1340 Wide Glide	85>86	82	-	-	-	-	-	-	N-1603	N-1602
VRSCA 1130 V-ROD	06>	06>	-	-	-	-	-	-	N-1611	N-1611
VRSCA/VRSCB 1130 V-ROD	02>04	02>04	-	-	-	-	-	-	N-1600	N-1600
VRSCAW 1250 V-ROD	08>	08>	-	-	-	-	-	-	N-1611	N-1611
VRSCD 1130 Night Rod	06>	06>	-	-	-	-	-	-	N-1611	N-1611
VRSCDX 1130 NIGHT ROD	08>	08>	-	-	-	-	-	-	N-1611	N-1611
VRSCDX 1250 Night Rod Special	08>	08>	-	-	-	-	-	-	N-1611	N-1611
VRSCF 1130 MUSCLE	09>	09>	-	-	-	-	-	-	N-1611	N-1611
VRSCF 1250 Muscle	09>	09>	-	-	-	-	-	-	N-1611	N-1611
VRSCR 1130 Street Rod	06>	06>	-	-	-	-	-	-	N-1611	N-1611
VRSCX 1130 V-ROD	08>	08>	-	-	-	-	-	-	N-1611	N-1611
VRSCX 1250 V-Rod	08>	08>	-	-	-	-	-	-	N-1611	N-1611
XL 1200 C Sportster Custom	04>	04>	-	-	-	-	-	-	N-1607	N-1615
XL 1200 C, CA, CB, CP Custom	14>	14>	-	-	-	-	-	-	N-1619	N-1621
XL 1200 E SPORTSTER ROADSTER	04>	04>	-	-	-	-	-	-	N-1607	N-1615
XL 1200 L Sportster Low	07>	07>	-	-	-	-	-	-	N-1607	N-1615
XL 1200 N Nightster (Spoke Wheel)	07>	07>	-	-	-	-	-	-	N-1607	N-1615
XL 1200 R Sportster Roadster	04>	04>	-	-	-	-	-	-	N-1607	N-1615
XL 1200 Sportster Custom	00>03	00>03	-	-	-	-	-	-	N-1600	N-1600
XL 1200 Sportster Sport*	00>03	00>03	-	-	-	-	-	-	N-1600	N-1600
XL 1200 V Seventy Two	11>13	11>13	-	-	-	-	-	-	N-1607	N-1615
XL 1200 V Seventy Two	14>	14>	-	-	-	-	-	-	N-1619	N-1621
XL 1200 X Sportster (Forty-Eight)	11>13	11>13	-	-	-	-	-	-	N-1607	N-1615
XL 1200 X Sportster (Forty-Eight)	14>	14>	-	-	-	-	-	-	N-1619	N-1621
XL 883 C Sportster Custom	04>13	04>13	-	-	-	-	-	-	N-1607	N-1615
XL 883 L Low	04>10	04>10	-	-	-	-	-	-	N-1607	N-1615
XL 883 L Sportster Low	06>13	06>13	-	-	-	-	-	-	N-1607	N-1615

H

**Street**

**Racing**

**Racing  
Extreme**

**CUSTOM**

## APLICAÇÃO

Ano



APLICAÇÃO	Ano		Street		Racing		Racing Extreme		CUSTOM	
<b>HARLEY-DAVIDSON</b>										
XL 883 L Super Low	11>13	11>13	-	-	-	-	-	-	N-1607	N-1615
XL 883 L Super Low	14>	14>	-	-	-	-	-	-	N-1619	N-1621
XL 883 N Iron	13	13	-	-	-	-	-	-	N-1607	N-1615
XL 883 N Iron	09>	09>	-	-	-	-	-	-	N-1607	N-1615
XL 883 N Iron	14>	14>	-	-	-	-	-	-	N-1619	N-1621
XL 883 R Roadster	10>13	10>13	-	-	-	-	-	-	N-1607	N-1615
XL 883 R Roadster	14>	14>	-	-	-	-	-	-	N-1619	N-1621
XL 883 R Sportster	00>03	00>03	-	-	-	-	-	-	N-1600	N-1600
XL 883 R Sportster	05>13	05>13	-	-	-	-	-	-	N-1607	N-1615
XL 883 Sportster	00>03	00>03	-	-	-	-	-	-	N-1600	N-1600
XL 883 Sportster	04>13	04>13	-	-	-	-	-	-	N-1607	N-1615
XL 883 Sportster Custom	00>03	00>03	-	-	-	-	-	-	N-1600	N-1600
XL 883 Sportster STD	04>08	04>08	-	-	-	-	-	-	N-1607	N-1615
XLCH 1000	73	-	-	-	-	-	-	-	N-1602	-
XLH 1100	87>88	87>88	-	-	-	-	-	-	N-1603	N-1605
XLH 1100 Sportster	85>86	-	-	-	-	-	-	-	N-1603	-
XLH 1200 Sportster	90>99	90>99	-	-	-	-	-	-	N-1603	N-1605
XLH 1200 Sportster	00>03	00>03	-	-	-	-	-	-	N-1600	N-1600
XLH 883 Sportster	85>86	-	-	-	-	-	-	-	N-1603	-
XLH 883 Sportster	87>89	87>89	-	-	-	-	-	-	N-1603	N-1605
XLH 883 Sportster	90>99	90>99	-	-	-	-	-	-	N-1603	N-1605
XLH 883 Sportster	00>03	00>03	-	-	-	-	-	-	N-1600	N-1600
XLH 883 Sportster Hugger	00>03	00>03	-	-	-	-	-	-	N-1600	N-1600
XLH Series	88>99	88>99	-	-	-	-	-	-	N-1603	N-1606
XLX 1100	86	-	-	-	-	-	-	-	N-1603	-
XR 1200	08>12	08>12	-	-	-	-	-	-	N-1607	N-1615
XR 1200 R	-	10>	-	-	-	-	-	-	-	N-1615
XR 1200 X	-	10>	-	-	-	-	-	-	-	N-1615
<b>HERO</b>										
ECO DELUXE FE	-	17>18	-	0320-CP	-	-	-	-	-	-
ECO DELUXE I3S	-	17>18	-	0320-CP	-	-	-	-	-	-
IGNITOR 125	-	18>19	-	0302-CP	-	-	-	-	-	-
Nipster 50	06>	-	N-1817	-	-	-	-	-	-	-
PASSION PRO 100	-	14>17	-	0302-CP	-	-	-	-	-	-
SPLENDOR ISMART 125	14>17	14>17	0302-CP	0302-CP	-	-	-	-	-	-
SUPER SPLENDOR 125	17>18	-	0302-CP	-	-	-	-	-	-	-
<b>HONDA</b>										
100 lead	00>	-	N-909	0302-CP	-	-	-	-	-	-
1100 ST ABS-TCS	92>95	92>95	-	-	N-930	-	N-930C	-	-	-
1100 ST PAN EUROPEAN	90>01	90>01	-	-	N-930	-	N-930C	-	-	-
AERO 100	90>93	90>94	-	0304-CP	-	-	-	-	-	-
ANF 125 INNOVA	03>	03>	N-949	0304-CP	-	-	-	-	-	-
ATC 250 R	85>86	85>86	N-909	N-909	-	-	-	-	-	-
ATC 250 X	85	-	N-909	-	-	-	-	-	-	-
ATC 350 X/ODISSEY	85	-	N-909	-	-	-	-	-	-	-
Biz 100	98>	98>	0302-CP	0320-CP	-	-	-	-	-	-
BIZ 100+	02>	02>	0302-CP	0320-CP	-	-	-	-	-	-
Biz 125	05>	05>	0302-CP	0320-CP	-	-	-	-	-	-
Biz 125+	05>	05>	N-917	0320-CP	-	-	-	-	-	-
C 90	80>90	80>90	0320-CP	0320-CP	-	-	-	-	-	-
C 90 E	80>90	80>90	0320-CP	0320-CP	-	-	-	-	-	-
C100 Dream	96>	96>	0304-CP	0304-CP	-	-	-	-	-	-
C70	67>90	67>90	0304-CP	0304-CP	-	-	-	-	-	-
CB 1000 F (Big One)	93>97	93>97	-	-	N-957	-	N-957C	-	-	-
CB 1000 F (Big One)	93>97	93>97	-	-	-	N-927	-	N-927C	-	-
CB 1000 R	08>	08>	-	-	N-988	N-1815	N-988C	N-1815C	-	-
CB 1000 R ABS	08>	08>	-	-	N-964	N-1815	N-964C	N-1815C	-	-
CB 110	12>17	-	0302-CP	-	-	-	-	-	-	-
CB 1100	.13	.13	N-964	N-927	-	-	N-964C	N-927C	-	-
CB 1100 HORNET	99>	99>	-	N-973	-	-	-	N-973C	-	-
CB 1100 X-11	00>03	00>03	N-973	N-973	-	-	N-973C	N-973C	-	-
CB 1100, EX	14>	14>	N-926	N-927	-	-	N-926C	N-927C	-	-
CB 125 E	14>17	-	0302-CP	-	-	-	-	-	-	-
CB 125 POWER SPORT	-	15>17	-	0302-CP	-	-	-	-	-	-

H

Street

Racing

Racing  
Extreme

CUSTOM

APLICAÇÃO

Ano



APLICAÇÃO	Ano		Street		Racing		Racing Extreme		CUSTOM	
<b>HONDA</b>										
CB 1300	05>	05>	-	-	N-926	N-927	N-926C	N-927C	-	-
CB 1300 R	-	02>	-	-	-	-	-	-	-	N-1621
CB 1300 R	02>04	02>04	-	-	N-926	-	N-977C	-	-	-
CB 1300 R	02>04	02>04	-	-	N-977	N-977	N-926C	N-977C	-	-
CB 1300 S	11>	11>	-	-	N-964	N-927	N-964C	N-927C	-	-
CB 1300 SF	-	98>	-	-	-	-	-	-	-	N-1621
CB 1300 Super Four	05>09	05>09	-	-	N-926	N-927	N-926C	N-927C	-	-
CB 1300 Super Four ABS	05>09	05>09	-	-	N-926	N-927	N-926C	N-927C	-	-
CB 1300 X-4	-	97>	-	-	-	-	-	-	-	N-1621
CB 150 INVICTA	-	11>13	-	N-1840	-	-	-	-	-	-
CB 150 INVICTA COBRA EXTREME	14>17	14>17	N-949	N-1840	-	-	-	-	-	-
CB 160 F STD	18>	-	N-949	-	-	-	-	-	-	-
CB 190 R	-	13>16	-	N-1840	-	-	-	-	-	-
CB 250 REBEL	86>	-	N-941	-	-	-	-	-	-	-
CB 250F TWISTER	15>	15>	-	-	N-930	-	N-930C	-	-	-
CB 300	09>	09>	N-940	N-1617	-	-	-	-	-	-
CB 300	-	09>	-	0302-CP	-	-	-	-	-	-
CB 300 R	09>	10>	-	-	N-1826	N-1824	N-1826C	N-1824C	-	-
CB 300 R ABS	09>	09>	-	-	N-964	N-927	N-964C	N-927C	-	-
CB 300 R ABS	09>	-	-	-	-	-	-	-	N-1619	-
CB 400	84>87	84>87	N-905	0309-CP	-	-	-	-	-	-
CB 400	>82	-	N-902	-	-	-	-	-	-	-
CB 400 I	83>	-	N-905	-	-	-	-	-	-	-
CB 400 I, II	83>	80>	N-905	0309-CP	-	-	-	-	-	-
CB 400 II	81	-	N-902	-	-	-	-	-	-	-
CB 400 II	83>84	-	N-905	-	-	-	-	-	-	-
CB 400 II	82>	-	N-907	0309-CP	-	-	-	-	-	-
CB 400 SUPER FOUR	92>95	92>95	-	-	-	N-1824	-	N-1824C	-	-
CB 450 C, E	-	-	N-905	N-905	-	-	-	-	-	-
CB 450 CUSTOM	85>87	-	N-905	-	-	-	-	-	-	-
CB 450 CUSTOM	88>	-	N-905	-	-	-	-	-	-	-
CB 450 DX (BRASIL)	88>	-	N-905	-	-	-	-	-	-	-
CB 450 SPORT	85>	-	N-905	-	-	-	-	-	-	-
CB 450 SR	-	89>	-	N-905	-	-	-	-	-	-
CB 450 TR	85>87	85>87	N-905	N-905	-	-	-	-	-	-
CB 450 TR, DX	84>87	84>87	N-905	0309-CP	-	-	-	-	-	-
CB 500	97>05	97>05	-	-	-	N-1073	-	N-1073C	-	-
CB 500 F	13>	13>	-	-	N-930	N-1824	N-930C	N-1824C	-	-
CB 500 F ABS	04>	04>	-	-	-	N-927	-	N-927C	-	-
CB 500 S	98>	98>	-	-	N-934	N-1073	N-934C	N-1073C	-	-
CB 500 VW	97>05	97>05	-	-	N-934	N-932	N-934C	N-932C	-	-
CB 500 X	13>	13>	-	-	N-930	N-1824	N-930C	N-1824C	-	-
CB 600 F	04>	04>	-	-	-	N-927	-	N-927C	-	-
CB 600 HORNET	04>06	04>06	-	-	N-930	N-927	N-930C	N-927C	-	-
CB 600 HORNET	07>	07>	-	-	N-930	N-962	N-930C	N-962C	-	-
CB 600 HORNET ABS	08>	08>	-	-	N-964	N-927	N-964C	N-927C	-	-
CB 600 JAPAN	98>	98>	-	-	N-926	N-927	N-926C	N-927C	-	-
CB 650 C	80>	-	N-902	-	-	-	-	-	-	-
CB 650 F	14>	14>	-	-	N-930	N-1824	N-930C	N-1824C	-	-
CB 750 F	77>80	77>80	N-907	N-907	-	-	-	-	-	-
CB 750 K/L	79>	-	N-902	-	-	-	-	-	-	-
CB 750 N, F, Seven Fifty	92>02	92>02	-	-	N-930	N-927	N-930C	N-927C	-	-
CB 750 PZ	81>	-	N-902	-	-	-	-	-	-	-
CB 750 SS	-	77>79	-	N-907	-	-	-	-	-	-
CB 900 F/F2	81>94	-	N-912	-	-	-	-	-	-	-
CB 900 Hornet	02>07	02>07	-	-	N-923	N-927	N-923C	N-927C	-	-
CB TWISTER 250	15>	15>	N-915	N-1840	-	-	-	-	-	-
CBF 1000	06>	06>	-	-	N-930	N-927	N-930C	N-927C	-	-
CBF 1000 ABS	06>	06>	-	-	N-964	N-964	N-964C	N-964C	-	N-1619
CBF 250	14>17	14>17	-	-	N-930	-	N-930C	-	-	-
CBR 1000 F	89>92	89>92	-	-	N-930	N-930	N-930C	N-930C	-	-
CBR 1000 F	-	89>92	-	N-915	-	-	-	-	-	-
CBR 1000 F, FP	93>99	93>99	-	-	N-968	N-968	N-968C	N-968C	-	-
CBR 1000 FIREBLADE	04>05	04>05	-	-	N-988	-	N-988C	-	-	-
CBR 1000 RR FIREBLADE	04>05	04>05	-	-	N-988	N-927	N-988C	N-927C	-	-
CBR 1000 RR FIREBLADE	06>08	06>08	-	-	N-988	N-962	N-988C	N-962C	-	-

H

**Street**

**Racing**

**Racing  
Extreme**

**CUSTOM**

### APLICAÇÃO

Ano



APLICAÇÃO	Ano								
<b>HONDA</b>									
CBR 1000 RR FIREBLADE	14>	14>	-	-	N-988	-	N-988C	-	-
CBR 1000 RR FIREBLADE / HANSSPREE Ed.	06>08	06>08	-	-	-	N-962	-	N-962C	-
CBR 1000 RR FIREBLADE ABS	09>	09>	-	-	N-988	N-962	N-988C	N-962C	-
CBR 1000 RR SP	14>	14>	-	-	N-1813	N-962	N-1813C	N-962C	-
CBR 1000 RR SP1 / SP2	17>	17>	-	-	N-962	-	N-962C	-	-
CBR 1100 XX SUPER BLACKBIRD	96>	96>	-	-	N-973	N-973	N-973C	N-973C	-
CBR 125 R	04>	-	N-949	-	-	-	-	-	-
CBR 150 R	00>	-	N-949	-	-	-	-	-	-
CBR 250 RAB/RAC/RAD ABS	12>17	12>17	-	-	-	N-1824	-	N-1824C	-
CBR 250R	11>17	11>17	-	-	N-930	-	N-930C	-	-
CBR 250R	11>	11>	N-915	N-1617	-	-	-	-	-
CBR 250R ABS	11>	11>	-	-	N-964	N-1824	N-964C	N-1824C	-
CBR 400 RR	88>94	88>94	-	-	N-930	N-1824	N-930C	N-1824C	-
CBR 450 SR	89>	89>	N-915	N-905	-	-	-	-	-
CBR 500R	13>	13>	-	-	N-930	N-1824	N-930C	N-1824C	-
CBR 600 F	11>	11>	-	-	N-930	N-962	N-930C	N-962C	-
CBR 600 F ABS	11>	11>	-	-	N-964	N-927	N-964C	N-927C	-
CBR 600 F (com ABS)	11>	11>	-	-	-	N-962	-	N-962C	-
CBR 600 F HURRICANE	87>90	-	N-909	-	-	-	-	-	-
CBR 600 F2	91>94	91>94	-	-	-	N-927	-	N-927C	-
CBR 600 F3/SJR	95>98	95>98	-	-	N-930	N-927	N-930C	N-927C	-
CBR 600 F4, SPORT	99>	99>	-	-	N-926	N-927	N-926C	N-927C	-
CBR 600 RR	03>04	03>04	-	-	N-926	-	N-926C	-	-
CBR 600 RR	05>06	05>06	-	-	N-988	N-927	N-988C	N-927C	-
CBR 600 RR	07>	07>	-	-	N-988	N-962	N-988C	N-962C	-
CBR 600 RR	99>	99>	-	-	-	N-927	-	N-927C	-
CBR 600 RR ABS	07>	07>	-	-	N-988	N-962	N-988C	N-962C	-
CBR 600 RR ABS	09>	09>	-	-	N-988	-	N-988C	-	-
CBR 600 RR / Limit Ed. / Repsol 600	07>	07>	-	-	N-988	N-962	N-988C	N-962C	-
CBR 600 SUPER SPORT	91>94	91>94	-	-	-	N-927	-	N-927C	-
CBR 600 SUPER SPORT	91>94	-	N-909	-	-	-	-	-	-
CBR 650 F	14>	14>	-	-	N-930	-	N-930C	-	-
CBR 900 RR, Fireblade	92>97	92>97	-	-	N-957	N-927	N-957C	N-927C	-
CBR 900 RR, Fireblade	98>03	98>03	-	-	N-926	N-927	N-926C	N-927C	-
CBR 919 RR, Fireblade	02>	02>	-	-	N-957	N-927	N-957C	N-927C	-
CBR 929 RR	00>01	00>01	-	-	N-926	N-927	N-926C	N-927C	-
CBR 954 RR	02>03	02>03	-	-	N-926	N-927	N-926C	N-927C	-
CBX 1000	77>80	-	N-907	-	-	-	-	-	-
CBX 1000	81>	-	N-912	-	-	-	-	-	-
CBX 1000	-	78>	-	N-907	-	-	-	-	-
CBX 125 AERO	-	89>	-	0304-CP	-	-	-	-	-
CBX 125 Custom	88>	-	N-941	-	-	-	-	-	-
CBX 150 Aero	89>	89>	N-906	0304-CP	-	-	-	-	-
CBX 200, Strada	94>04	94>04	N-906	0314-CP	-	-	-	-	-
CBX 250	84>98	-	N-941	-	-	-	-	-	-
CBX 250 TWISTER	01>	-	N-940	0302-CP	-	-	-	-	-
CBX 750 F	>	-	N-912	-	-	-	-	-	-
CBX 750 F	86>	86>	N-911	N-911	-	-	-	-	-
CBX TWISTER 250	01>09	01>09	-	-	N-1826	-	N-1826C	-	-
CBZ 160 ES	02>07	-	N-940	-	-	-	-	-	-
CD 100	98>02	-	0302-CP	-	-	-	-	-	-
CG 125	>82	>82	0304-CP	0304-CP	-	-	-	-	-
CG 125	76>82	76>82	0304-CP	0304-CP	-	-	-	-	-
CG 125	-	83>99	-	0304-CP	-	-	-	-	-
CG 125 Cargo	00>	00>	0302-CP	0302-CP	-	-	-	-	-
CG 125 Cargo ES	14>	14>	0302-CP	0302-CP	-	-	-	-	-
CG 125 Cargo ESD	14>	14>	N-949	0302-CP	-	-	-	-	-
CG 125 Cargo KS	14>	14>	0302-CP	0302-CP	-	-	-	-	-
CG 125 FAN	08>	08>	0302-CP	0302-CP	-	-	-	-	-
CG 125 FAN	05>	05>	0302-CP	0302-CP	-	-	-	-	-
CG 125 FAN ES	14>	14>	0302-CP	0302-CP	-	-	-	-	-
CG 125 FAN ESD	14>	14>	N-949	0302-CP	-	-	-	-	-
CG 125 FAN KS	14>	14>	0302-CP	0302-CP	-	-	-	-	-
CG 125 TODAY/TITAN	-	91>99	-	0304-CP	-	-	-	-	-
CG 125, CG 125 Today e CG 125 Titan	83>99	83>99	0312-CP	0304-CP	-	-	-	-	-
CG 150 Cargo ESD	14>	14>	N-949	0302-CP	-	-	-	-	-

H

Street

Racing

Racing  
Extreme

CUSTOM

APLICAÇÃO

Ano



APLICAÇÃO	Ano								
<b>HONDA</b>									
CG 150 FAN	09>	09>	N-949	0302-CP	-	-	-	-	-
CG 150 Titan ESD	09>	09>	N-949	0302-CP	-	-	-	-	-
CG 150 Titan EX	09>	09>	N-949	0302-CP	-	-	-	-	-
CG 150 TITAN MIX	09>	-	N-949	-	-	-	-	-	-
CG 160 FAN ESDi	15>	15>	N-949	0302-CP	-	-	-	-	-
CG CARGO 160	18>	-	N-1882	-	-	-	-	-	-
CG FAN 160	18>	-	N-1882	-	-	-	-	-	-
CG Titan 125 Cargo	00>	00>	0302-CP	0302-CP	-	-	-	-	-
CG Titan 125 ES	00>03	00>03	N-906	0302-CP	-	-	-	-	-
CG Titan 125 ES	04>	04>	0302-CP	0302-CP	-	-	-	-	-
CG Titan 125 KS	00>	00>	0302-CP	0302-CP	-	-	-	-	-
CG Titan 125 KSE	02>03	02>03	0302-CP	0302-CP	-	-	-	-	-
CG Titan 150 CBS	-	14>	-	0302-CP	-	-	-	-	-
CG Titan 150 ES / KS	04>	04>	0302-CP	0302-CP	-	-	-	-	-
CG Titan 150 ESD	04>08	04>08	N-906	0302-CP	-	-	-	-	-
CG Titan 150 ESD CBS	-	-	-	0302-CP	-	-	-	-	-
CG Titan 150 EX CBS	15>	15>	N-1836	0302-CP	-	-	-	-	-
CG Titan 150 JOB	04>	04>	0302-CP	0302-CP	-	-	-	-	-
CG Titan 150 SPORT	04>08	04>08	N-906	0302-CP	-	-	-	-	-
CG Titan 150 START	14>	14>	0302-CP	0302-CP	-	-	-	-	-
CG TITAN 160	18>	-	N-1882	-	-	-	-	-	-
CG Titan 160 EX ESD	15>	15>	N-1836	0302-CP	-	-	-	-	-
CH 250 FEEWAY FUSION	88>	-	N-909	-	-	-	-	-	-
CH 250 SPACY	85>	-	N-909	-	-	-	-	-	-
CH 250 SPACY	88>	-	N-909	-	-	-	-	-	-
CH 80	85>01	-	0304-CP	-	-	-	-	-	-
CLICK 125i	-	14>17	-	0302-CP	-	-	-	-	-
CM 200	-	80>82	-	0302-CP	-	-	-	-	-
CN 250 SPACY	88>89	-	N-909	-	-	-	-	-	-
CN SCOOTER 250	88>92	-	N-912	-	-	-	-	-	-
CR 125	02>	02>	-	-	N-991	N-995	N-991C	N-995C	-
CR 125 R	95>01	95>01	-	-	N-991	N-1075	N-991C	N-1075C	-
CR 125 RH, RJ , RK	87>94	87>94	-	-	N-991	N-1075	N-991C	N-1075C	-
CR 250	02>	02>	-	-	N-991	N-995	N-991C	N-995C	-
CR 250 R	87>01	87>01	-	-	N-991	N-1075	N-991C	N-1075C	-
CR 500	84>86	-	-	-	N-909	-	-	-	-
CR 500 R	87>01	87>01	-	-	N-991	N-1075	N-991C	N-1075C	-
CR 500 RE/RF	84>85	-	N-909	-	-	-	-	-	-
CR 500 RG	86	-	N-909	-	-	-	-	-	-
CR 80 R, RB	92>02	92>02	-	-	N-1831	N-1075	N-1831C	N-1075C	-
CR 85 R, R EXPERT	03>	03>	-	-	N-1831	N-1075	N-1831C	N-1075C	-
CRE 125	02>	02>	-	-	N-991	N-995	N-991C	N-995C	-
CRE 250	02>	02>	-	-	N-991	N-995	N-991C	N-995C	-
CRE 250 F	04>	04>	-	-	N-991	N-995	N-991C	N-995C	-
CRE 450 Efi	09>	09>	-	-	N-991	N-995	N-991C	N-995C	-
CRE 450 F	02>	02>	-	-	N-991	N-995	N-991C	N-995C	-
CRF 100 F	12>	12>	0302-CP	0320-CP	-	-	-	-	-
CRF 150 F	03>	03>	-	0313-CP	N-991	-	N-991C	-	-
CRF 150 F	-	03>07	-	0320-CP	-	-	-	-	-
CRF 150 R	07>	07>	-	-	N-1831	N-995	N-1831C	N-995C	-
CRF 230	04>	04>	-	0320-CP	N-991	-	N-991C	-	-
CRF 230	-	03>05	-	0320-CP	-	-	-	-	-
CRF 230 F	-	03>05	-	0320-CP	-	-	-	-	-
CRF 230 L	08>	08>	-	-	N-991	N-1075	N-991C	N-1075C	-
CRF 250 L	14>	14>	N-1834	N-1840	-	-	-	-	-
CRF 250 R, Efi	04>	04>	-	-	N-991	N-995	N-991C	N-995C	-
CRF 250 RC	04>17	04>17	-	-	N-991	-	N-991C	-	-
CRF 250 X	08>	08>	-	-	N-991	N-995	N-991C	N-995C	-
CRF 450 Efi	09>	09>	-	-	-	N-995	-	N-995C	-
CRF 450 R	02>	02>	-	-	N-991	N-995	N-991C	N-995C	-
CRF 450 X	05>	05>	-	-	N-991	N-995	N-991C	N-995C	-
CRM 250 R	91>92	91>92	-	-	N-991	-	N-991C	-	-
CROSSRUNNER 800	11>	11>	-	-	-	N-1815	-	N-1815C	-
CTX 700	14>	14>	-	-	N-930	N-1824	N-930C	N-1824C	-
CTX 700 ND ABS	14>	14>	-	-	N-930	N-1824	N-930C	N-1824C	-
CTX 700 D ABS	14>	14>	-	-	N-930	N-1824	N-930C	N-1824C	-

H

**Street**

**Racing**

**Racing  
Extreme**

**CUSTOM**

### APLICAÇÃO

Ano



APLICAÇÃO	Ano		Street		Racing		Racing Extreme		CUSTOM	
<b>HONDA</b>										
CTX 700 N	14>	14>	-	-	N-930	N-1824	N-930C	N-1824C	-	-
CUB 90	90>93	-	-	-	0304-CP	-	-	-	-	-
DREAM NEO	14>17	14>17	0302-CP	0302-CP	-	-	-	-	-	-
DUTY 125	-	83>	-	0320-CP	-	-	-	-	-	-
ECO 100	03>09	03>09	0302-CP	0320-CP	-	-	-	-	-	-
ECO 100 DELUXE ES	09>13	-	0302-CP	-	-	-	-	-	-	-
ECO 100 PLUS	09>12	09>12	0302-CP	0320-CP	-	-	-	-	-	-
ELITE 125	19>	19>	N-909	0302-CP	-	-	-	-	-	-
ELITE 125	-	08>14	-	0320-CP	-	-	-	-	-	-
ELITE 125 +	15>17	15>17	0302-CP	0302-CP	-	-	-	-	-	-
FES 125 PANTHEON	98>06	03>	-	-	N-989	N-1824	N-989C	N-1824C	-	-
FES 125 S-WING	08>	-	-	-	-	-	-	-	N-1619	-
FES 125 S-WING	07>13	07>13	-	-	N-964	-	N-964C	-	-	-
FES 150 PANTHEON	98>06	03>	-	-	N-989	N-1824	N-989C	N-1824C	-	-
FES 150 S-WING	08>	-	-	-	-	-	-	-	N-1619	-
FES 150 S-WING	07>13	07>13	-	-	N-964	-	N-964C	-	N-1619	-
FES 250 FORESIGHT	00>	00>	-	-	N-989	N-1824	N-989C	N-1824C	N-1619	-
FMX 650	05>	05>08	-	-	N-930	N-1824	N-930C	N-1824C	-	-
FMX 650	-	05>	-	-	-	N-927	-	N-927C	-	-
FORZA 250	05>	-	-	-	-	-	-	-	N-1619	-
GL 1000 K3 GOLD WING	78>79	-	N-907	-	-	-	-	-	-	-
GL 145	85>	-	N-906	-	-	-	-	-	-	-
GL 1500 F6 VALKYRIE	96>02	96>02	-	-	N-930	N-915	N-930C	-	-	-
GL 1800 GOLD WING	01>	01>	-	-	N-989	N-989	N-989C	N-989C	-	-
GL 1800 GOLD WING	01>	01>	-	-	N-973	-	N-973C	-	-	-
GL 1800 GOLD WING F6B	13>	13>	-	-	N-973	-	N-973C	-	-	-
GL 1800 GOLD WING F6B	13>	13>	-	-	N-989	N-989	N-989C	N-989C	-	-
LEAD 110	00>	00>	N-909	0302-CP	-	-	-	-	-	-
MBX 125 RWB	84>	-	N-941	-	-	-	-	-	-	-
MBX 50 SD/SF	83>85	-	N-941	-	-	-	-	-	-	-
MBX 80	-	82>	-	0320-CP	-	-	-	-	-	-
MBX 80 DX	82>	-	N-941	-	-	-	-	-	-	-
MBX 80 SW/SWD	83>	83>	N-941	0320-CP	-	-	-	-	-	-
ML 125	83>	78>87	N-906	0304-CP	-	-	-	-	-	-
ML/TURUNA 125	-	>82	-	0304-CP	-	-	-	-	-	-
NC 700 D Integra	12>	12>	-	-	N-964	N-927	N-964C	N-927C	-	-
NC 700 S	12>	12>	-	-	N-930	-	N-930C	-	-	-
NC 700 SA ABS	12>	12>	-	-	N-964	N-927	N-964C	N-927C	-	-
NC 700 SD ABS	12>	12>	-	-	N-964	N-927	N-964C	N-927C	-	-
NC 700 X	12>	12>	-	-	N-930	N-1824	N-930C	N-1824C	-	-
NC 700 XA ABS	12>	12>	-	-	N-964	N-927	N-964C	N-927C	-	-
NC 700 XD ABS	12>	12>	-	-	N-964	N-927	N-964C	N-927C	-	-
NC 750 D Integra (RC71) 750 40	14>	14>	-	-	-	N-1824	-	N-1824C	-	-
NC 750 S	14>	14>	-	-	N-930	-	N-930C	-	-	-
NC 750 S ABS	14>	14>	-	-	N-930	-	N-930C	-	-	-
NC 750 S DCT 750	14>	14>	-	-	-	N-1824	-	N-1824C	-	-
NC 750 Travel edition 745 40	18>	18>	-	-	-	N-1824	-	N-1824C	-	-
NC 750 X	14>	14>	-	-	N-930	-	N-930C	-	-	-
NC 750 X (RC72) 750 35	14>15	14>15	-	-	-	N-1824	-	N-1824C	-	-
NC 750 X (RC72) 750 40	14>	14>	-	-	-	N-1824	-	N-1824C	-	-
NC 750 X ABS	14>	14>	-	-	N-930	-	N-930C	-	-	-
NES 125 / 150	01>	-	-	-	N-909	-	-	-	-	-
NR 750	92>	92>	-	-	-	N-927	-	N-927C	-	-
NSR 50	-	89>90	-	0304-CP	-	-	-	-	-	-
NSR 50 FP/FR/FS	93>95	-	N-941	-	-	-	-	-	-	-
NSR 50 SK/SP/SR/SS	89>95	-	N-941	-	-	-	-	-	-	-
NSR 80 J-2/K/L/N (HC06)	88>92	-	N-941	-	-	-	-	-	-	-
NSS/OS 250	05>	-	-	-	-	-	-	-	N-1619	-
NT 650 V	94>	94>	-	-	-	N-1824	-	N-1824C	-	-
NT 650 V Deauville	.01	.01	-	-	N-934	N-927	N-934C	N-927C	-	-
NT 650 V Deauville	98>00	98>00	-	-	N-934	N-1824	N-934C	N-1824C	-	-
NT 650 V Deauville	02>05	02>05	-	-	N-973	N-973	N-973C	N-973C	-	-
NT 700 DEAUVILLE ABS	06>	06>	-	-	N-973	N-973	N-964C	N-973C	-	-
NT 700 DEAUVILLE ABS	06>	06>	-	-	N-964	-	N-973C	-	-	-
NT 700 V Varadero	10>	10>	-	-	N-973	N-973	N-973C	N-973C	-	-
NT 700 V Varadero	10>	10>	-	-	N-964	-	N-964C	-	-	-

H

Street

Racing

Racing  
Extreme

CUSTOM

APLICAÇÃO

Ano



APLICAÇÃO	Ano									
<b>HONDA</b>										
NT 700 V Varadero ABS	10>	10>	-	-	N-973	N-973	N-973C	N-973C	-	-
NT 700 V Varadero ABS	10>	10>	-	-	N-964	-	N-964C	-	-	-
NX 150	88>	88>	N-917	0313-CP	-	-	-	-	-	-
NX 200	93>	93>	N-917	0313-CP	-	-	-	-	-	-
NX 350 Sahara	87>	87>	N-917	0314-CP	-	-	-	-	-	-
NX 4 Falcon 400	99>08	99>08	N-917	N-943	-	-	-	-	-	-
NX 400 4 FALCON	99>	99>	-	-	-	N-1075	-	N-1075C	-	-
NX 400i Falcon	12>	12>	N-917	N-943	-	-	-	-	-	-
NX 500 DOMINATOR	97>	97>	-	-	N-993	N-1073	N-993C	N-1073C	-	-
NX 650 DOMINATOR	97>	97>	-	-	N-993	N-1073	N-993C	N-1073C	-	-
NX 650 DOMINATOR	-	93>96	-	-	-	N-1824	-	N-1824C	-	-
NX 650 DOMINATOR J-K	88>92	88>92	-	-	-	N-1824	-	N-1824C	-	-
NX 650 K	95>98	95>98	-	-	N-934	-	N-934C	-	-	-
NX R 200	94>	-	N-917	-	-	-	-	-	-	-
NXR 125 Bros KS / ES	03>	03>	0302-CP	0320-CP	-	-	-	-	-	-
NXR 125 BROS	04>11	04>11	0302-CP	0302-CP	-	-	-	-	-	-
NXR 150 BROS ES	03>	-	0302-CP	-	-	-	-	-	-	-
NXR 150 Bros ESD	03>	03>	N-917	0320-CP	-	-	-	-	-	-
NXR 160 BROS	18>	-	N-1886	-	-	-	-	-	-	-
NXR 160 Bros ESD	14>	14>	N-917	0320-CP	-	-	-	-	-	-
NXR 160 Bros ESDD	14>	14>	N-917	N-1840	-	-	-	-	-	-
NXR 160 BROS ESDD	18>	-	N-1886	-	-	-	-	-	-	-
PASSION 100	01>03	01>03	0302-CP	0302-CP	-	-	-	-	-	-
PC 800 Pacific Coast	89>97	89>97	-	-	N-930	-	N-930C	-	-	-
PCX 150	13>18	-	N-1802	-	-	-	-	-	-	-
PCX 150 (C/ABS)	19>	19>	N-1834	N-1891	-	-	-	-	-	-
PCX 150 (S/ABS)	19>	13>	N-1886	0302-CP	-	-	-	-	-	-
POP 100	Todas	Todas	0320-CP	0320-CP	-	-	-	-	-	-
POP 110i	15>	15>	0320-CP	0320-CP	-	-	-	-	-	-
RS 125 R COMPETIÇÃO	91>95	91>95	-	-	N-930	-	N-930C	-	-	-
SH 125	02>	13>18	N-909	N-1891	-	-	-	-	-	-
SH 150i	19>	09>12	N-915	N-1891	-	-	-	-	-	-
SH 300	-	07>18	-	N-1891	-	-	-	-	-	-
SH 300 i	07>	07>	-	-	N-964	-	N-964C	-	-	-
SH150	-	17>	-	N-1891	-	-	-	-	-	-
SH150	-	13>19	-	N-1891	-	-	-	-	-	-
SH300i	19>	-	N-915	-	-	-	-	-	-	-
SHi 300	07>	-	-	-	-	-	-	-	N-1619	-
SLR 650	97>98	97>98	-	-	N-934	N-932	N-934C	N-932C	-	-
SLR 650	97>	97>	-	-	-	N-1073	-	N-1073C	-	-
SPLENDOR	-	03>08	-	-	-	0320-CP	-	-	-	-
SPLENDOR 100	94>04	94>04	0302-CP	0302-CP	-	-	-	-	-	-
SPLENDOR 100 NXG	11>13	-	0302-CP	-	-	-	-	-	-	-
SPLENDOR 100 NXG ES	11>13	-	0302-CP	-	-	-	-	-	-	-
SPLENDOR NXG ES	-	03>08	-	0320-CP	-	-	-	-	-	-
ST 1100 A6 - ABS-TCS-CBS	96>	96>	-	-	N-973	-	N-973C	-	-	-
ST 1100 A6 - ABS-TCS-CBS	96>	96>	-	-	N-989	N-989	N-989C	N-989C	-	-
ST 70 DAX	78>	78>	-	-	0304-CP	0320-CP	-	-	-	-
STX 1300 PAN EUROPEAN ABS	02>	02>	-	-	-	N-973	-	N-973C	-	-
TRANSALPINO 700	08>11	08>11	-	-	-	N-1824	-	N-1824C	-	-
TRX 250 FOURTRAX	-	87	-	N-909	-	-	-	-	-	-
TRX 250 R	-	86>89	-	N-909	-	-	-	-	-	-
Turuna 125	83>	83>	N-906	0304-CP	-	-	-	-	-	-
VF 1100 C/S	83>86	-	N-912	-	-	-	-	-	-	-
VF 750 C/ MAGNA	94>98	-	N-915	-	-	-	-	-	-	-
VFR 1200 XC, XDC	12>	12>	-	-	N-964	-	N-964C	-	-	-
VFR 1200 F	10>	10>	-	-	N-1815	N-1815	N-1815C	N-1815C	-	-
VFR 750 F	88>98	88>98	-	-	N-930	N-930	N-930C	N-930C	-	-
VFR 750 F	-	88>98	-	-	-	N-915	-	-	-	-
VFR 750 R	88>93	88>93	-	-	N-957	-	N-957C	-	-	-
VFR 800 / VFR 800 ABS	06>13	06>13	-	-	N-964	N-973	N-964C	N-973C	-	-
VFR 800 / VFR 800 ABS	06>13	06>13	-	-	N-973	-	N-973C	-	-	-
VFR 800 F	14-17	14-17	-	-	N-1815	-	N-1815C	-	-	-
VFR 800 F	14-17	14-17	-	-	N-988	N-1815	N-988C	N-1815C	-	-
VFR 800 X CROSSRUNNER	15>	15>	-	-	-	-	N-988C	-	-	-
VFR 800 X CROSSRUNNER TRAVEL ED.	15>	15>	-	-	-	-	N-988C	-	-	-

H

**Street**

**Racing**

**Racing  
Extreme**

**CUSTOM**

### APLICAÇÃO

Ano

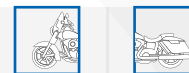

APLICAÇÃO	Ano		Street		Racing		Racing Extreme		CUSTOM	
<b>HONDA</b>										
VIGOR 650	99>02	99>	-	-	N-934	N-1073	N-934C	N-1073C	-	-
VT 1100 C2 Shadow A.C.E / Sabre	95>	95>	-	-	N-930	N-927	N-930C	N-927C	-	-
VT 1100 C3 Shadow Aero	98>	98>	-	-	N-930	N-927	N-930C	N-927C	-	-
VT 1100 T Shadow	98>	98>	-	-	N-930	N-927	N-930C	N-927C	-	-
VT 1300 Fury	10>	10>	-	-	N-930	N-927	N-930C	N-927C	-	-
VT 1300 Fury ABS	10>	10>	-	-	N-973	N-973	N-973C	N-973C	-	-
VT 1300 Fury ABS	10>	10>	-	-	N-964	-	N-964C	-	-	-
VT 600 C, Shadow	94>00	94>00	-	-	N-930	-	N-930C	-	-	-
VT 600 CD, Shadow VLT	94>00	94>00	-	-	N-930	-	N-930C	-	-	-
VT 750 RS, S	11>	11>	-	-	N-930	-	N-930C	-	-	-
VT 750 Shadow	04>	04>	-	-	N-930	-	N-930C	-	-	-
VT 750 SHADOW	97>04	-	N-915	-	-	-	-	-	-	-
VT1100 C Shadow	94>96	94>96	-	-	N-930	-	N-930C	-	-	-
VTR 1000 SP-1, SP-2	00>	00>	-	-	N-926	N-927	N-926C	N-927C	-	-
VTR 1000 Super Hawk, F Firestorm	97>	97>	-	-	N-957	N-927	N-957C	N-927C	-	-
VTX 1300	04>09	04>09	-	-	N-930	-	N-930C	-	-	-
VTX 1300 C/S	03>	03>	-	-	-	N-927	-	N-927C	-	-
VTX 1800	01>	01>	-	-	N-973	N-973	N-973C	N-973C	-	-
WAVE 110	12>16	-	N-1788	-	-	-	-	-	-	-
X-ADV	-	19>	-	N-1617	-	-	-	-	-	-
XL / XR 600R	83>87	-	N-909	-	-	-	-	-	-	-
XL 100	80>85	80>85	0320-CP	0320-CP	-	-	-	-	-	-
XL 1000 VARADERO	.99	.99	-	-	N-973	N-973	N-973C	N-973C	-	-
XL 1000 VARADERO	07>	07>	-	-	N-964	N-973	N-964C	N-973C	-	-
XL 1000 VARADERO ABS	04>	04>	-	-	N-964	N-973	N-964C	N-973C	-	-
XL 1000 VARADERO ABS	04>	04>	-	-	N-973	N-973	N-973C	N-973C	-	-
XL 125	80>00	80>00	0320-CP	0320-CP	-	-	-	-	-	-
XL 125 S	-	83>	-	0320-CP	-	-	-	-	-	-
XL 125, Duty 125	84>	84>	0312-CP	0320-CP	-	-	-	-	-	-
XL 125R	97>	97>	0312-CP	0313-CP	-	-	-	-	-	-
XL 185	80>99	80>99	0320-CP	0320-CP	-	-	-	-	-	-
XL 200	95>01	95>01	-	-	N-991	-	N-991C	-	-	-
XL 250	91>95	91>95	-	-	N-991	-	N-991C	-	-	-
XL 250, XL 250 R	82>	82>	0312-CP	0313-CP	-	-	-	-	-	-
XL 600 V TRANSALPINO	91>99	91>99	-	-	-	N-1824	-	N-1824C	-	-
XL 600 V TRANSALPINO	94>96	-	N-915	-	-	-	-	-	-	-
XL 600 V TRANSALPINO	97>99	97>99	-	-	N-991	-	N-991C	-	-	-
XL 700 TRANSALP	08>	08>	-	-	N-991	N-1824	N-991C	N-1824C	-	-
XL 700 TRANSALP ABS	08>	08>	-	-	N-964	N-927	N-964C	N-927C	-	-
XLR 125	00>	00>	0302-CP	0313-CP	-	-	-	-	-	-
XLR 250	-	82>84	-	0313-CP	-	-	-	-	-	-
XLX 250 R	-	84>	-	0313-CP	-	-	-	-	-	-
XLX 350	87>	87>	N-909	0313-CP	-	-	-	-	-	-
XR 125 BRIO	03>13	03>13	-	-	N-991	-	N-991C	-	-	-
XR 125 L	13>15	13>15	-	-	N-991	-	N-991C	-	-	-
XR 125 L II	15>17	15>17	-	-	N-991	-	N-991C	-	-	-
XR 200 R	94>	93>	N-917	0313-CP	-	-	-	-	-	-
XR 200 R	80>02	80>02	-	-	0320-CP	0320-CP	-	-	-	-
XR 250 L	93>97	93>97	-	-	N-991	N-1075	N-991C	N-1075C	-	-
XR 250 R	90>95	90>95	-	-	-	N-1075	-	N-1075C	-	-
XR 250 S/R	96>	96>	-	-	-	N-1075	-	N-1075C	-	-
XR 250 TORNADO	01>12	01>12	-	-	N-991	-	N-991C	-	-	-
XR 250 TORNADO	01>	01>	N-917	0302-CP	-	-	-	-	-	-
XR 400 R	96>	96>	-	-	N-991	N-1075	N-991C	N-1075C	-	-
XR 400 SUPER MOTARD	00>	00>	-	-	N-991	-	N-991C	-	-	-
XR 400 SUPERMOTARD	00>	00>	-	-	-	N-1075	-	N-1075C	-	-
XR 440 R	00>	00>	-	-	N-991	N-1075	N-991C	N-1075C	-	-
XR 600 R	91>00	91>00	-	-	N-991	N-1075	N-991C	N-1075C	-	-
XR 600 R	-	83>90	-	0320-CP	-	-	-	-	-	-
XR 650 L	-	-	-	-	N-991	N-1075	N-991C	N-1075C	-	-
XR 650 R	00>	93>	-	-	N-991	N-1075	N-991C	N-1075C	-	-
XRE 190	16>19	16>19	-	-	N-991	-	N-991C	-	-	-
XRE 190	16>	16>	N-917	N-1840	-	-	-	-	-	-
XRE 300	09>	09>	-	-	-	N-1075	-	N-1075C	-	-
XRE 300 ABS	09>	-	-	-	-	-	-	-	N-1619	-
XRE 300 ABS	19>	19>	N-917	N-1840	-	-	-	-	-	-

H

Street

Racing

Racing  
Extreme

CUSTOM

APLICAÇÃO

Ano



APLICAÇÃO	Ano									
<b>HONDA</b>										
XRE 300 C/ ABS	09>	09>	-	-	N-964	N-927	N-964C	N-927C	-	-
XRE 300 S/ABS	09>	09>	N-917	N-943	-	-	-	-	-	-
XRV 650 AFRICA TWIN	88>89	88>89	-	-	-	N-1824	-	N-1824C	-	-
XRV 750 AFRICA TWIN	93>	90>03	-	-	N-991	N-1824	N-991C	N-1824C	-	-
XRV 750 AFRICA TWIN	90>92	-	N-909	-	-	-	-	-	-	-
<b>HUSABERG</b>										
E 550 E	04>	04>	-	-	N-993	N-1073	N-993C	N-1073C	-	-
FC 450	03>	03>	-	-	N-993	N-1073	N-993C	N-1073C	-	-
FE 250	13>	13>	-	-	N-993	N-997	N-993C	N-997C	-	-
FE 350	13>	13>	-	-	N-993	N-997	N-993C	N-997C	-	-
FE 390	10>	10>	-	-	N-993	N-997	N-993C	N-997C	-	-
FE 400	99>03	99>03	-	-	N-993	N-1073	N-993C	N-1073C	-	-
FE 450	09>	09>	-	-	N-993	N-997	N-993C	N-997C	-	-
FE 450 E	04>	04>	-	-	N-993	N-1073	N-993C	N-1073C	-	-
FE 501	13>	13>	-	-	N-993	N-997	N-993C	N-997C	-	-
FE 501 S, E	99>04	99>04	-	-	N-993	N-1073	N-993C	N-1073C	-	-
FE 550 E	04>	04>	-	-	N-993	N-1073	N-993C	N-1073C	-	-
FE 570	09>	09>	-	-	N-993	N-997	N-993C	N-997C	-	-
FE 650 e	01>	01>	-	-	N-993	N-1073	N-993C	N-1073C	-	-
FS 400 E / C	01>03	01>03	-	-	N-929	N-1073	N-929C	N-1073C	-	-
FS 450 C	06>	06>	-	-	-	N-1073	-	N-1073C	-	-
FS 450 E / C	03>05	03>05	-	-	N-929	N-1073	N-929C	N-1073C	-	-
FS 650 e / C	01>05	01>05	-	-	-	N-1073	-	N-1073C	-	-
FS 650 e / C	06>	06>	-	-	-	N-1073	-	N-1073C	-	-
FX 450 E	03>	03>	-	-	N-993	N-1073	N-993C	N-1073C	-	-
FX 650 e	01>	01>	-	-	N-993	N-1073	N-993C	N-1073C	-	-
TE 125	12>	12>	-	-	N-993	N-997	N-993C	N-997C	-	-
TE 250	11>	11>	-	-	N-993	N-997	N-993C	N-997C	-	-
TE 250	11>	11>	-	-	-	-	-	-	-	-
TE 250	11>	11>	-	-	-	-	-	-	-	-
TE 250	11>	11>	-	-	-	-	-	-	-	-
TE 300	11>	11>	-	-	N-993	N-997	N-993C	N-997C	-	-
TE 300	11>	11>	-	-	-	-	-	-	-	-
TE 300	11>	11>	-	-	-	-	-	-	-	-
TE 300	11>	11>	-	-	-	-	-	-	-	-
CR 125	96>04	96>04	-	-	N-993	N-1073	N-993C	N-1073C	-	-
CR 125	05>	05>	-	-	N-993	N-997	N-993C	N-997C	-	-
LT 610	00>	00>	-	-	N-1804	N-1073	N-1804C	N-1073C	-	-
Nuda 900	12>	12>	-	-	N-1804	N-1073	N-1804C	N-1073C	-	-
SM 125	96>	96>	-	-	N-993	N-1073	N-993C	N-1073C	-	-
SM 450 R	05	03>04	-	-	N-1811	N-1073	N-1811C	N-1073C	-	-
SM 450 R	06>	06>	-	-	N-1811	N-997	N-1811C	N-997C	-	-
SM 510 R	05	05	-	-	N-1811	N-1073	N-1811C	N-1073C	-	-
SM 510 R	06>	06>	-	-	N-1811	N-997	N-1811C	N-997C	-	-
SM 610 ie	07>	07>	-	-	N-1811	N-997	N-1811C	N-997C	-	-
SM 610 SUPER MOTARD, S	98>	98>	-	-	N-1804	N-1073	N-1804C	N-1073C	-	-
SM 610 SUPER MOTARD/S	98>	98>	-	-	N-993	-	N-993C	-	-	-
SM 630	10>	10>	-	-	N-1811	N-997	N-1811C	N-997C	-	-
SMR 630	04>	04>	-	-	N-1804	N-1073	N-1804C	N-1073C	-	-
STR 650 CRC	07>	07>	-	-	N-1811	N-997	N-1811C	N-997C	-	-
TC 250 / 450 / 510	02>03	02>03	-	-	N-993	N-1073	N-993C	N-1073C	-	-
TC 250 / 450 / 510	04>	04>	-	-	N-993	N-997	N-993C	N-997C	-	-
TC 610	96>	96>	-	-	N-993	N-1073	N-993C	N-1073C	-	-
TE 250	02>	02>	-	-	N-993	N-1073	N-993C	N-1073C	-	-
TE 250 4T	10>	10>	-	-	N-993	N-997	N-993C	N-997C	-	-
TE 450	02>	02>	-	-	N-993	N-1073	N-993C	N-1073C	-	-
TE 510	02>10	02>10	-	-	N-993	N-1073	N-993C	N-1073C	-	-
TE 510 CENTENNIAL	04>	04>	-	-	-	N-997	-	N-997C	-	-
TE 511	11>	11>	-	-	N-993	N-997	N-993C	N-997C	-	-
TE 570	01>	01>	-	-	N-993	N-1073	N-993C	N-1073C	-	-
TE 610 RALLIE	96>	96>	-	-	N-993	N-1073	N-993C	N-1073C	-	-
TE 630	10>	10>	-	-	N-1811	N-997	N-1811C	N-997C	-	-
WR 125	96>	96>	-	-	N-993	N-1073	N-993C	N-1073C	-	-
WR 250	96>	96>	-	-	N-993	N-1073	N-993C	N-1073C	-	-
WRE 125	96>	96>	-	-	N-993	N-1073	N-993C	N-1073C	-	-

H-I-J-K

**Street**

**Racing**

**Racing  
Extreme**

**CUSTOM**

### APLICAÇÃO

Ano



APLICAÇÃO	Ano		Street		Racing		Racing Extreme		CUSTOM	
<b>HYOSUNG</b>										
AQUILA 125	00>	00>	-	-	N-1828	-	N-1828C	-	-	-
GT COMET	03>	03>	N-941	N-941	-	-	-	-	-	-
<b>INDIAN</b>										
CHIEF CLASSIC 1800	14>	14>	-	-	N-930	-	N-930C	-	-	-
CHIEF CLASSIC 1800	14>	14>	-	-	N-1812	-	N-1812C	-	-	-
CHIEF VINTAGE 1800	14>	14>	-	-	N-1812	-	N-930C	-	-	-
CHIEF VINTAGE 1800	14>	14>	-	-	N-930	-	N-1812C	-	-	-
CHIEFTAIN 1800	14>	14>	-	-	N-1812	-	N-1812C	-	-	-
CHIEFTAIN 1800	14>	14>	-	-	N-930	-	N-930C	-	-	-
ROADMASTER 1800	15>	15>	-	-	N-930	-	N-930C	-	-	-
ROADMASTER 1800	15>	15>	-	-	N-1812	-	N-1812C	-	-	-
<b>ITALIKA</b>										
AT 110 (MÉXICO)	06>15	-	N-941	-	-	-	-	-	-	-
FT 150	06>19	-	N-940	-	-	-	-	-	-	-
<b>JIALING</b>										
CICLON 125	07>10	-	N-940	-	-	-	-	-	-	-
JH 125 L	94>	94>	0320-CP	0320-CP	-	-	-	-	-	-
<b>JINCHENG</b>										
JC 100	98>	-	N-906	-	-	-	-	-	-	-
<b>KASINSKI</b>										
COMET 150	10>	-	N-906	-	-	-	-	-	-	-
COMET 250	05>	05>	N-941	N-941	-	-	-	-	-	-
COMET GT 650 / GTR	04>	04>	N-941	N-941	-	-	-	-	-	-
CRUISE 125	-	96>	-	0321-CP	-	-	-	-	-	-
CRZ 150 Off Road	11>	11>	-	-	-	-	N-1822C	-	-	-
CRZ 150 Supermoto	11>	11>	-	-	-	-	N-1822C	-	-	-
FURIA 250	02>	02>	-	-	N-970	-	N-970C	-	-	-
GF 125 EKO	-	03>	-	0304-CP	-	-	-	-	-	-
GF 125 EKO	-	97>	-	0321-CP	-	-	-	-	-	-
MAGIK 125	02>	02>	-	0321-CP	-	-	N-1013	-	-	-
MIDAS 110	-	97>	-	0321-CP	-	-	-	-	-	-
MIRAGE 150	11>	11>	-	-	-	-	N-1822C	-	-	-
MIRAGE 250	01>	-	N-941	-	-	-	-	-	-	-
MIRAGE 650	06>	06>	N-941	N-941	-	-	-	-	-	-
Prima 150 Scooter	10>	-	N-906	-	-	-	-	-	-	-
RX 125	00>	00>	N-941	0321-CP	-	-	-	-	-	-
SETA 150	08>	-	N-906	-	-	-	-	-	-	-
SF PRIMA SCOOTER 50	99>	-	N-947	-	-	-	-	-	-	-
SOFT 50	10>	-	N-906	-	-	-	-	-	-	-
SUPER CAB SCOOTER 100	96>	-	N-947	-	-	-	-	-	-	-
SUPER CAB SCOOTER 50	96>	-	N-947	-	-	-	-	-	-	-
Win 110	11>	08>	N-941	0320-CP	-	-	-	-	-	-
<b>KAWASAKI</b>										
ATV BRUTE FORCE 750	06>17	06>17	N-940	N-942	-	-	-	-	-	-
BRUTE FORCE 650	06>14	06>14	-	-	N-1828	-	N-1828C	-	-	-
CHEER	01>02	-	-	-	N-940	-	-	-	-	-
ER 6 650 F	09>12	09>12	-	-	N-959	-	N-959C	-	-	-
ER 6 650 N	06>16	06>16	-	-	N-959	-	N-959C	-	-	-
ER 6 N	06>18	06>18	-	-	N-958	-	N-958C	-	-	-
ER 650 6F	09>12	09>12	-	-	N-958	-	N-958C	-	-	-
ER-5 500	01>	01>	-	-	N-959	-	N-959C	-	-	-
ER-6f 650 (LD)	06>	06>	-	-	-	N-981	-	N-981C	-	-
ER-6n 650 (LD)	06>	06>	-	-	-	N-981	-	N-981C	-	-
EX 250 F2	08>12	-	-	-	N-940	-	-	-	-	-
GPZ 1100	95>96	95>96	-	-	N-958	-	N-958C	-	-	-
GPZ 1100	95>96	95>96	-	-	N-959	-	N-959C	-	-	-
GPZ 1100 (LD) ABS, HORIZONT	97>	97>	-	-	-	N-981	-	N-981C	-	-
GPZ 1100 (LD) (ZX 1100)	95>96	95>96	-	-	-	N-981	-	N-981C	-	-
GPZ 900R	90>96	90>96	-	-	N-929	-	N-929C	-	-	-
GTR 1400	-	07>	-	-	-	-	-	-	-	N-1621

K

Street

Racing

Racing  
Extreme

CUSTOM

APLICAÇÃO

Ano



APLICAÇÃO	Ano									
<b>KAWASAKI</b>										
GTR 1400	07>	07>	-	-	-	-	-	N-977C	-	-
GTR 1400 ABS	-	07>	-	-	-	-	-	-	-	N-1621
H2 1000 NINJA	15>	15>	-	-	N-1813	N-1818	N-1813C	N-1818C	-	-
H2R 1000 NINJA	15>	15>	-	-	N-1813	N-1818	N-1813C	N-1818C	-	-
K1 115	97>00	-	-	-	N-940	-	-	-	-	-
KAZE 125	05>10	-	-	-	N-940	-	-	-	-	-
KAZE 130	05>10	-	-	-	N-942	-	-	-	-	-
KDX 125	-	89>97	-	-	-	N-946	-	-	-	-
KDX 200	94>99	94>99	-	-	N-991	-	N-991C	-	-	-
KDX 200	95>06	95>06	-	-	N-991	-	N-991C	-	-	-
KDX 200	-	94>99	-	-	-	N-946	-	-	-	-
KDX 200 E5	93>	93>	-	-	N-1828	-	N-1828C	-	-	-
KDX 220	94>99	94>99	-	-	N-991	-	N-991C	-	-	-
KDX 220 R	97>	97>	-	-	N-991	-	N-991C	-	-	-
KDX 220 R	-	97>	-	-	-	N-946	-	-	-	-
KDX 250 SR/D14-D4	91>94	91>94	-	-	N-1828	-	N-1828C	-	-	-
KFX 700 V-FORCE	04>	04>	-	-	-	-	N-1832C	-	-	-
KL 250 SUPER SHERPA	00>	00>	-	-	-	-	N-1832C	-	-	-
KLE 650 VERSYS	07>10	07>10	-	-	N-958	-	N-958C	-	-	-
KLE 650 VERSYS	07>	07>	-	-	-	N-981	-	N-981C	-	-
KLE 650 VERSYS	15>	15>	-	-	-	N-1824	-	N-1824C	-	-
KLF 300 C1-C12 BAYOU (LE)	89>	89>	-	-	N-1828	-	N-1828C	-	-	-
KLF 400 B1-B7 BAYOU (LE)	93>99	93>99	-	-	N-1828	-	N-1828C	-	-	-
KLR 650	08>	08>	-	-	N-1826	-	N-1826C	-	-	-
KLR 650	08>	08>	-	-	N-1828	-	N-1828C	-	-	-
KLR 650	99>	99>	-	-	N-959	-	N-959C	-	-	-
KLR 650	08>	08>	-	-	-	N-1826	-	N-1826C	-	-
KLV 1000	04>	04>	-	-	N-958	-	N-958C	-	-	-
KLV 1000	04>	04>	-	-	N-959	-	N-959C	-	-	-
KLV 1000 (LD)	04>	04>	-	-	-	N-927	-	N-927C	-	-
KLV 1000 (LD)	04>	04>	-	-	-	-	-	-	-	-
KLX 150	12>16	12>16	-	-	N-942	N-906	-	-	-	-
KLX 250	09>	09>	-	-	N-1828	N-1075	N-1828C	N-1075C	-	-
KLX 250	93>96	93>96	-	-	N-991	-	N-991C	-	-	-
KLX 250	98>07	98>07	-	-	N-991	N-1075	N-991C	N-1075C	-	-
KLX 250	13>17	93>96	-	-	N-942	N-946	-	-	-	-
KLX 250 S	12>15	12>15	-	-	N-1828	-	N-1828C	-	-	-
KLX 250 S	13>17	-	-	-	N-942	-	-	-	-	-
KLX 300 A 7 F	96>00	96>00	-	-	N-991	-	N-991C	-	-	-
KLX 300 R	97>	97>	-	-	N-991	N-1075	N-991C	N-1075C	-	-
KLX 400	03>04	03>04	-	-	N-1828	-	N-1828C	-	-	-
KLX 400 R / 400 SR	03>	03>	-	-	N-991	N-1075	N-991C	N-1075C	-	-
KLX 450 R	06>	06>	-	-	N-991	N-1011C	N-991C	-	-	-
KLX 600 R	-	93>	-	-	-	N-946	-	-	-	-
KLX 650	93>96	96	-	-	N-991	N-1075	N-991C	N-1075C	-	-
KLX 650 R	-	93>97	-	-	-	N-946	-	-	-	-
KMX 125	87>02	-	-	-	N-947	-	-	-	-	-
KMX 80	87>	-	-	-	N-947	-	-	-	-	-
KR 500 ES	-	93>	-	-	-	N-946	-	-	-	-
KSV 700 V-FORCE	04>	04>	-	-	-	-	N-1832C	-	-	-
KVF 360	03>09	-	-	-	-	-	N-906	-	-	-
KVF 400	97>02	-	-	-	-	-	N-906	-	-	-
KVF 650	01>03	01>03	-	-	-	-	N-1832C	-	-	-
KVF 700 PRAIRIE	04>	04>	-	-	-	-	N-1832C	-	-	-
KVF 750 BRUTE FORCE 4x4 (LE)	05>	05>	-	-	N-1828	N-1828C	-	-	-	-
KX 100	97>	97>	-	-	-	-	N-1832C	N-1831C	-	-
KX 125	94>	95>	-	-	N-991	N-1075	N-991C	N-1075C	-	-
KX 125	89>93	89>93	-	-	N-1828	-	N-1828C	-	-	-
KX 250	94>	95>	-	-	N-991	N-1075	N-991C	N-1075C	-	-
KX 250	80>07	80>07	-	-	N-1828	-	N-1828C	-	-	-
KX 500	96>	96>	-	-	N-991	N-1075	N-991C	N-1075C	-	-
KX 500	80>93	80>93	-	-	N-1828	-	N-1828C	-	-	-
KX 500	-	89>95	-	-	-	N-946	-	-	-	-
KX 65	00>	00>	-	-	-	-	-	N-1831C	-	-
KX 65	-	12>17	-	-	-	N-906	-	-	-	-
KX 80	97>00	97>00	-	-	-	-	N-1832C	N-1831C	-	-

K

**Street**

**Racing**

**Racing  
Extreme**

**CUSTOM**

APLICAÇÃO	Ano									
<b>KAWASAKI</b>										
KX 85	01>	01>	-	-	-	-	N-1832C	N-1831C	-	-
KX-F 250	04>	04>	-	-	N-991	-	N-991C	N-1011C	-	-
KX-F 450	06>	06>	-	-	N-991	-	N-991C	N-1011C	-	-
KZ 1000	02>05	03>	-	-	N-959	N-981	N-959C	N-981C	-	-
MAGIC II	04>08	-	-	-	N-940	-	-	-	-	-
NINJA 250R	09>	09>	-	-	N-940	N-940	-	-	-	-
NINJA 300R	12>	12>	-	-	N-940	N-940	-	-	-	-
NINJA 250	08>12	08>12	-	-	N-940	N-940	-	-	-	-
NINJA 250 R	09>	09>	-	-	N-1826	N-1826	N-1826C	N-1826C	-	-
NINJA 300	13>	13>	-	-	N-1826	N-1826	N-1826C	N-1826C	-	-
NINJA 300	12>17	12>17	-	-	N-940	N-940	-	-	-	-
NINJA 300 ABS	13>	13>	-	-	N-1826	N-1826	N-1826C	N-1826C	-	-
VERSYS 1000	12>	12>	-	-	N-929	N-927	N-929C	N-927C	-	-
VERSYS 250	-	17>19	-	-	-	N-940	-	-	-	-
VERSYS 300	-	17>19	-	-	-	N-940	-	-	-	-
VERSYS 650	07>14	07>14	-	-	N-959	-	N-959C	-	-	-
VICTOR M 150	95>00	-	-	-	N-940	-	-	-	-	-
VN 1500 CLASSIC (VULCAN)	97>	97>	-	-	N-959	-	N-959C	-	-	-
VN 1500 CLASSIC Fi (VULCAN)	00>	00>	-	-	N-959	N-958	N-959C	N-958C	-	-
VN 1500 CLASSIC Fi (VULCAN)	00>	-	-	-	N-958	-	N-958C	-	-	-
VN 1500 CLASSIC TOURER (LD) (VULCAN)	00>	00>	-	-	N-958	N-958	N-958C	N-958C	-	-
VN 1500 CLASSIC TOURER Fi (LD) (VULCAN)	00>	00>	-	-	N-958	N-958	N-958C	N-958C	-	-
VN 1500 DRIFTER (VULCAN)	99>02	99>02	-	-	N-959	N-958	N-959C	N-958C	-	-
VN 1500 DRIFTER (VULCAN)	99>02	99>02	-	-	N-958	-	N-958C	-	-	-
VN 1500 MEAN STREAK (VULCAN)	02>03	02>03	-	-	N-922	N-958	N-922C	N-958C	-	-
VN 1500 MEAN STREAK (VULCAN)	02>03	02>03	-	-	N-958	-	N-958C	-	-	-
VN 1600 CLASSIC	03>	03>	-	-	N-959	-	N-959C	-	-	-
VN 1600 CLASSIC (LD) (VULCAN)	03>	03>	-	-	N-958	N-958	N-958C	N-958C	-	-
VN 1600 MEAN STREAK (VULCAN)	.04	.04	-	-	N-922	-	N-922C	-	-	-
VN 1600 MEAN STREAK (VULCAN)	.04	.04	-	-	N-958	N-958	N-958C	N-958C	-	-
VN 1600 MEAN STREAK (VULCAN)	05>	05>	-	-	N-967	N-958	N-967C	N-958C	-	-
VN 1600 MEAN STREAK (VULCAN)	05>	05>	-	-	N-958	-	N-958C	-	-	-
VN 2000 (VULCAN)	04>	04>	-	-	N-929	N-958	N-958C	N-958C	-	-
VN 2000 (VULCAN)	04>	04>	-	-	N-958	-	N-929C	-	-	-
VN 800 CLASSIC (VULCAN)	98>	98>	-	-	N-959	-	N-959C	-	-	-
VN 800 DRIFTER (VULCAN)	99>02	99>02	-	-	N-958	N-958	N-958C	N-958C	-	-
VN 800 DRIFTER (VULCAN)	99>02	99>02	-	-	N-959	-	N-959C	-	-	-
VN 900 CUSTOM (VULCAN)	07>	07>	-	-	N-959	N-958	N-959C	N-958C	-	-
VN 900 CUSTOM (VULCAN)	07>	07>	-	-	N-958	-	N-958C	-	-	-
VN 900 CLASSIC (VULCAN)	06>	06>	-	-	N-959	N-958	N-959C	N-958C	-	-
VN 900 CLASSIC (VULCAN)	06>	06>	-	-	N-958	-	N-958C	-	-	-
VULCAM 650	15>	15>	-	-	-	N-927	-	N-927C	-	-
VULCAN 650 S	15>	15>	-	-	-	N-1824	-	N-1824C	-	-
WIND 125	04>06	04>06	-	-	N-993	-	N-993C	-	-	-
WIND 125	07>10	-	-	-	N-940	-	-	-	-	-
Z 1000	03>06	03>06	-	-	N-1812	N-981	N-1812C	N-981C	-	-
Z 1000	07>09	07>09	-	-	N-967	N-927	N-967C	N-927C	-	-
Z 1000	14>	14>	-	-	N-983	N-981	N-983C	N-981C	-	-
Z 1000 NINJA (rad.cal)	14>	14>	-	-	N-983	-	N-983C	-	-	-
Z 1000 (rad.cal)	10>13	10>13	-	-	N-983	N-927	N-983C	N-927C	-	-
Z 1000 (rad.cal)	14>	14>	-	-	N-983	-	N-983C	-	-	-
Z 1000 SE	14>	14>	-	-	N-983	N-981	N-983C	N-981C	-	-
Z 1000 SX	11>13	11>13	-	-	N-983	N-981	N-983C	N-981C	-	-
Z 1000 SX	14>	14>	-	-	N-983	N-981	N-983C	N-981C	-	-
Z 250 SL	14>17	14>17	-	-	N-940	N-940	-	-	-	-
Z 300	15>	15>	-	-	N-1826	-	N-1826C	-	-	-
Z 750	07>	07>	-	-	N-930	N-927	N-930C	N-927C	-	-
Z 750 (LD)	04>	04>	-	-	-	N-981	-	N-981C	-	-
Z 750 ABS	07>	07>	-	-	N-930	N-927	N-930C	N-927C	-	-
Z 750 R	11>	07>	-	-	N-967	N-1824	N-967C	N-1824C	-	-
Z 750S	06>10	06>10	-	-	N-959	-	N-959C	-	-	-
Z 750S	06>10	06>10	-	-	N-958	-	N-958C	-	-	-
Z 800	13>	13>	-	-	N-930	N-1824	N-930C	-	-	-
Z 800	13>	13>	-	-	N-1812	-	N-1812C	N-1824C	-	-
Z 800 e	13>	13>	-	-	N-930	N-1824	N-1812C	N-1824C	-	-
Z 800 e	13>	13>	-	-	N-1812	-	N-930C	-	-	-

K

Street

Racing

Racing  
Extreme

CUSTOM

APLICAÇÃO

Ano



**KAWASAKI**

Z 800 e ABS	13>	13>	-	-	N-1812	-	N-1812C	-	-	-
ZEPHIR 1100	97>	97>	-	-	N-958	-	N-958C	-	-	-
ZEPHIR 1100	97>	97>	-	-	N-959	-	N-959C	-	-	-
ZR 1100 A1/A2/A3/A4 Zephyr	92>95	92>95	-	-	N-929	-	N-929C	-	-	-
ZR 750 SEPHIR	96>	96>	-	-	N-959	-	N-959C	-	-	-
ZR 750 ZEPHIR	96>	96>	-	-	N-958	-	N-958C	-	-	-
ZR-7 750	99>	99>	-	-	N-959	-	N-959C	-	-	-
ZR-7 750 (LD)	99>	99>	-	-	N-958	N-958	N-958C	N-958C	-	-
ZR-7S 750	01>	01>	-	-	N-959	-	N-959C	-	-	-
ZR-7S 750	01>	01>	-	-	-	-	-	-	-	-
ZR-7S 750 (LD)	01>	01>	-	-	N-958	N-958	N-958C	N-958C	-	-
ZR-7S 750 (LE)	01>	01>	-	-	N-958	N-958	N-958C	N-958C	-	-
ZRX 1100	96>00	96>00	-	-	N-922	N-924	N-922C	N-924C	-	-
ZRX 1200 / R / S	01>	01>	-	-	N-922	N-924	N-922C	N-924C	-	-
ZX 1000 10R	11>	11>	-	-	-	N-962	-	N-962C	-	-
ZX 1100 (ZX-11)	93>97	93>97	-	-	N-929	N-924	N-929C	N-924C	-	-
ZX 1100 D1-D5	93>97	93>97	-	-	-	N-924	-	N-924C	-	-
ZX-10 R 1000 NINJA	04>07	04>07	-	-	N-967	N-981	N-967C	N-981C	-	-
ZX10R NINJA	08>10	08>10	-	-	N-983	N-981	N-983C	N-981C	-	-
ZX10R NINJA	11>	11>	-	-	N-983	-	N-983C	-	-	-
ZX-10R Winter test Ed. 1000	16>	16>	-	-	-	-	N-962C	-	-	-
ZX-10RR Ninja 998	17>	17>	-	-	-	-	N-962C	-	-	-
ZX-11	93>97	93>97	-	-	-	N-924	-	N-924C	-	-
ZX-12 R 1200 NINJA	00>03	00>03	-	-	N-922	N-924	N-922C	N-924C	-	-
ZX-12R 1200 NINJA	04>	04>	-	-	-	N-924	-	N-924C	-	-
ZX-14R 1400	07>	07>	-	-	-	N-977	-	N-977C	-	-
ZX-14R 1400 ABS	07>	07>	-	-	-	N-977	-	N-977C	-	-
ZX-6 R 636 NINJA	.02	.02	-	-	N-922	N-981	N-922C	N-981C	-	-
ZX-6 R 636 NINJA	03>06	03>06	-	-	N-967	N-981	N-967C	N-981C	-	-
ZX-6 R 636 NINJA	13>	13>	-	-	N-926	N-962	N-926C	N-962C	-	-
ZX-6 RR 600 NINJA	03>06	03>06	-	-	N-967	N-981	N-967C	N-981C	-	-
ZX-6R 600 D1,D4 (ZX-6)	90>93	90>93	-	-	N-929	-	N-929C	-	-	-
ZX-6R 600 E1-E5 Ninja (ZX6)	93>97	93>97	-	-	N-929	N-981	N-929C	N-981C	-	-
ZX-6R 600 F1-F3 Ninja (ZX6R)	95>97	95>97	-	-	N-929	N-981	N-929C	N-981C	-	-
ZX-6R 600 NINJA	98>01	98>01	-	-	N-922	N-981	N-922C	N-981C	-	-
ZX-6R 600 NINJA	07>	07>	-	-	N-967	N-981	N-967C	N-981C	-	-
ZX-7R 750 NINJA/	89>95	89>95	-	-	N-929	N-924	N-929C	N-924C	-	-
ZX-7R 750 NINJA/ P1-P8	96>03	96>03	-	-	N-922	N-924	N-922C	N-924C	-	-
ZX-7RR 750 NINJA N1	96>02	96>02	-	-	-	N-977	-	N-977C	-	-
ZX-9R 900 NINJA	94>95	94>95	-	-	N-929	N-981	N-929C	N-981C	-	-
ZX-9R 900 NINJA	96>01	96>01	-	-	N-922	N-981	N-922C	N-981C	-	-
ZX-9R 900 NINJA	02>	02>	-	-	N-1812	N-981	N-1812C	N-981C	-	-
ZXR 1100	96>00	96>00	-	-	N-922	N-924	N-922C	N-924C	-	-
ZX-R 750 RR NINJA N1		96>02	-	-	-	-	-	-	-	N-1621
ZXR 750R	89>95	89>95	-	-	N-929	N-924	N-929C	N-924C	-	-
ZZR 1100	90>01	90>01	-	-	N-929	N-924	N-929C	N-924C	-	-
ZZR 1200	02>	02>	-	-	-	N-924	-	N-924C	-	-
ZZR 1400	-	06>	-	-	-	-	-	-	-	N-1621
ZZR 1400	07>	07>	-	-	-	N-977	-	N-977C	-	-
ZZR 1400 ABS	-	06>	-	-	-	-	-	-	-	N-1621
ZZR 1400 SE	-	16>	-	-	-	-	-	-	-	N-1621
ZZR600	90>92	90>92	-	-	N-929	-	N-929C	-	-	-
ZZR600	93>05	93>05	-	-	N-929	N-981	N-929C	N-981C	-	-

**KTM**

250 XC/XC-F	11>	11>	-	-	N-993	-	N-993C	-	-	-
950 ADVENTURE/S	04>06	04>06	-	-	-	N-993	-	N-993C	-	-
ADVENTURE 1190	13>	13>	-	-	N-1804	N-993	N-1804C	N-993C	-	-
ADVENTURE 900 / S	04>06	04>06	-	-	-	N-993	-	N-993C	-	-
ADVENTURE 990	06>	06>	-	-	N-934	N-993	N-934C	N-993C	-	-
ADVENTURE 990 / S	06>08	06>08	-	-	-	N-993	-	N-993C	-	-
ADVENTURE ABS 990	06>	06>	-	-	N-934	N-993	N-934C	N-993C	-	-
ADVENTURE LC8 950	02>	02>	-	-	N-934	N-932	N-934C	N-932C	-	-
ADVENTURE R 990	10>	10>	-	-	N-934	N-993	N-934C	N-993C	-	-
ADVENTURE S 990	06>	06>	-	-	N-934	N-993	N-934C	N-993C	-	-
DUKE R 690	10>11	10>11	-	-	N-1811	N-932	N-1811C	N-932C	-	-

K

**Street**

**Racing**

**Racing  
Extreme**

**CUSTOM**

### APLICAÇÃO

Ano



APLICAÇÃO	Ano	Street	Racing	Racing Extreme	Custom				
<b>KTM</b>									
DUKE R 690	14>	14>	-	N-1813	N-932	N-1813C	N-932C	-	-
DUKE 125	11>17	11>17	-	-	N-932	-	N-932C	-	-
DUKE 125	11>	11>	-	-	N-1073	-	N-1073C	-	-
DUKE 200	12>	12>	-	-	N-932	-	N-932C	-	-
DUKE 200	12>	12>	-	-	N-1073	-	N-1073C	-	-
DUKE 200	12>16	12>16	-	-	N-932	-	N-932C	-	-
DUKE 250	18>19	18>19	-	-	N-932	-	N-932C	-	-
DUKE 390	13>	13>	-	-	N-1073	-	N-1073C	-	-
DUKE 390	13>	13>	-	-	N-932	-	N-932C	-	-
DUKE 640	03>	03>	-	N-1804	N-1073	N-1804C	N-1073C	-	-
DUKE 640	>	>	-	-	N-932	-	N-932C	-	-
DUKE 690	08>11	08>11	-	N-1811	N-932	N-1811C	N-932C	-	-
DUKE ABS 690	12>	12>	-	N-1804	N-932	N-932C	N-932C	-	-
DUKE ABS 690	12>	12>	-	N-932	-	N-1804C	-	-	-
ENDURO 690	08>	08>	-	N-934	N-932	N-934C	N-932C	-	-
ENDURO R 690	09>	09>	-	N-934	N-932	N-934C	N-932C	-	-
EXC 125	92>05	92>05	-	N-993	-	N-993C	-	-	-
EXC 125 ENDURO	04>	04>	-	N-993	N-997	N-993C	N-997C	-	-
EXC 125 ENDURO	99>03	99>03	-	N-993	N-1073	N-993C	N-1073C	-	-
EXC 250 (2T)	11>	11>	-	-	N-997	-	N-997C	-	-
EXC 250 F (4T)	11>	11>	-	-	N-997	-	N-997C	-	-
EXC 300	00>08	00>08	-	N-993	-	N-993C	-	-	-
EXC 300 (2T) SIX DAYS/XC	11>	11>	-	N-993	-	N-993C	-	-	-
EXC 400 RACING	00>03	00>03	-	N-993	N-1073	N-993C	N-1073C	-	-
EXC 400 RACING / 450 RACING	04>	04>	-	N-993	N-997	N-993C	N-997C	-	-
EXC 520 RACING	00>02	00>02	-	N-993	N-1073	N-993C	N-1073C	-	-
EXC 525 RACING / SX 525 RACING	03	03	-	N-993	N-1073	N-993C	N-1073C	-	-
EXC 525 RACING / SX 525 RACING	04>	04>	-	N-993	N-997	N-993C	N-997C	-	-
EXC 530 (4T) SIX DAYS	11>	11>	-	N-993	-	N-993C	-	-	-
EXC 530 (4T) SIX DAYS	11>	11>	-	-	-	-	-	-	-
EXC ENDURO 200 / 250 / 300	04>	04>	-	N-993	N-997	N-993C	N-997C	-	-
EXC ENDURO 200 / 250 / 300	99>03	99>03	-	N-993	N-1073	N-993C	N-1073C	-	-
EXC ENDURO 380	99>	99>	-	N-993	N-1073	N-993C	N-1073C	-	-
EXC RACING 250 (4T)	06>	06>	-	-	N-997	-	N-997C	-	-
EXC-F ENDURO 250	07>	07>	-	N-993	N-997	N-993C	N-997C	-	-
EXC-F ENDURO 350	11>	11>	-	N-993	N-997	N-993C	N-997C	-	-
EXC-F/XC-F 350	11>	11>	-	N-993	-	N-993C	-	-	-
EXC-R 450 (4T)	08>	08>	-	-	N-997	-	N-997C	-	-
LC4 600 SIX DAYS	92>	92>	-	N-993	N-993C	-	-	-	-
LC4 620 COMPETITION	99>	99>	-	N-993	N-1073	N-993C	N-1073C	-	-
LC4 620 COMPETITION SUPER MOTO	00>	00>	-	N-993	N-1073	N-993C	N-1073C	-	-
LC4 620 SUPER COMPETITION	01>	01>	-	N-993	N-1073	N-993C	N-1073C	-	-
LC4 625 SC SUPERMOTO	02>	02>	-	N-993	N-1073	N-993C	N-1073C	-	-
LC4 640 ADVENTURE	05>	05>	-	N-934	N-1073	N-934C	N-1073C	-	-
LC4 640 ADVENTURE	99>04	99>04	-	N-993	N-1073	N-993C	N-1073C	-	-
LC4 640 E SUPERMOTO	99>02	99>02	-	N-993	N-1073	N-993C	N-1073C	-	-
LC4 640 ENDURO	99>	99>	-	N-993	N-1073	N-993C	N-1073C	-	-
LC4 640 SUPERMOTO	04>	03>	-	N-1804	N-1073	N-1804C	N-1073C	-	-
LC4 660 RALLYE	01>	01>	-	N-993	N-1073	N-993C	N-1073C	-	-
LC4 660 REPLICIA	02>	02>	-	-	N-1073	-	N-1073C	-	-
LC4-E 400 ENDURO	99>	99>	-	N-993	N-1073	N-993C	N-1073C	-	-
LC8 950 ADVENTURE	02>	02>	-	-	N-1073	-	N-1073C	-	-
MX 380	98>	98>	-	N-993	N-1073	N-993C	N-1073C	-	-
R 690	14>	14>	-	-	N-1073	-	N-1073C	-	-
RACING 505	07>	07>	-	N-993	N-993C	N-993	N-993C	-	-
RC 125	14>	14>	-	-	N-1073	-	N-1073C	-	-
RC 200	15>18	15>18	-	-	N-932	-	N-932C	-	-
RC 200	14>	14>	-	-	N-1073	-	N-1073C	-	-
RC 390	14>	14>	-	-	N-1073	-	N-1073C	-	-
RC8 1190	08>	08>	-	N-1818	N-1818	N-1818C	N-1818C	-	-
RC8 1190	08>	08>	-	N-1813	-	N-1813C	-	-	-
RC8 1190 R	09>	09>	-	N-1813	N-1818	N-1813C	N-1818C	-	-
RC8 1190 R Track	11>	11>	-	N-1813	N-1818	N-1813C	N-1818C	-	-
RC8 1190 Superbike R	09>	09>	-	N-1813	N-1818	N-1813C	N-1818C	-	-
SM 690	07>	07>	-	N-1811	N-932	N-1811C	N-932C	-	-
SM 950	07>	07>	-	N-1811	N-993	N-1811C	N-993C	-	-

K

Street

Racing

Racing  
Extreme

CUSTOM

APLICAÇÃO

Ano



APLICAÇÃO	Ano									
<b>KTM</b>										
SMC 625	05>	05>	-	-	N-1804	N-932	N-1804C	N-932C	-	-
SMC 660	03>	03>	-	-	-	N-1073	-	N-1073C	-	-
SMC 660 SUPERMOTO	04>	04>	-	-	N-1804	-	N-1804C	-	-	-
SMC 660 SUPERMOTO	03>	03>	-	-	N-932	N-932	N-932C	N-932C	-	-
SMC 690	08>	08>	-	-	N-1811	N-932	N-1811C	N-932C	-	-
SMC 950	08>	08>	-	-	N-1811	N-993	N-1811C	N-993C	-	-
SMR 560	06>	06>	-	-	N-993	-	N-993C	-	-	-
SUPER DUKE 990	04>	04>	-	-	N-1811	N-932	N-1811C	N-932C	-	-
SUPER DUKE 990	04>	05>06	-	-	-	N-1073	-	N-1073C	-	-
SUPER DUKE 990 R	07>	07>	-	-	-	N-1073	-	N-1073C	-	-
SUPER DUKE R 1290	11>	11>	-	-	N-1813	N-1818	N-1813C	N-1818C	-	-
SUPER DUKE R 990	09>	09>	-	-	N-1811	N-932	N-1811C	N-932C	-	-
SUPERENDURO R 950	06>	06>	-	-	N-934	N-993	N-934C	N-993C	-	-
SUPERMOTO R 690	08>	08>	-	-	N-1811	N-932	N-1811C	N-932C	-	-
SUPERMOTO 660	03>	03>	-	-	-	N-1073	-	N-1073C	-	-
SUPERMOTO 990	07>	07>	-	-	N-1811	N-993	N-1811C	N-993C	-	-
SUPERMOTO R 990	10>	10>	-	-	N-1813	N-993	N-1813C	N-993C	-	-
SUPERMOTO T 990	09>	09>	-	-	N-1811	N-993	N-1811C	N-993C	-	-
SX 125	96>03	96>03	-	-	N-993	N-1073	N-993C	N-1073C	-	-
SX 125	04>	04>	-	-	N-993	N-997	N-993C	N-997C	-	-
SX 200	03>04	03>04	-	-	N-993	N-997	N-993C	N-997C	-	-
SX 250	03>	03>	-	-	N-993	N-997	N-993C	N-997C	-	-
SX 250	96>02	96>02	-	-	N-993	N-1073	N-993C	N-1073C	-	-
SX 250 F	06>	06>	-	-	-	N-997	-	N-997C	-	-
SX 380	98>02	98>02	-	-	N-993	N-1073	N-993C	N-1073C	-	-
SX 400 RACING	00>02	00>02	-	-	N-993	N-1073	N-993C	N-1073C	-	-
SX 450	03>	03>	-	-	N-993	N-997	N-993C	N-997C	-	-
SX 450 SM FACTORY REPLICA / SMR	04>	04>	-	-	-	N-997	-	N-997C	-	-
SX 520 RACING	00>02	00>02	-	-	N-993	N-1073	N-993C	N-1073C	-	-
SX 525 RACING	03>	03>	-	-	-	N-1073	-	N-1073C	-	-
SX 525 SMR	04>	04>	-	-	-	N-997	-	N-997C	-	-
SX 620	95>99	95>99	-	-	N-993	N-1073	N-993C	N-1073C	-	-
SX 65	-	00>03	-	-	-	N-914	-	-	-	-
SXC 400 TIAINEN REPLICA	99>00	99>00	-	-	N-993	N-1073	N-993C	N-1073C	-	-
SXC 625	05>06	05>06	-	-	N-993	-	N-993C	-	-	-
SX-F 250	06>	06>	-	-	N-993	N-997	N-993C	N-997C	-	-
SX-F 350	11>	11>	-	-	N-993	N-997	N-993C	N-997C	-	-
SX-F 450	03>	03>	-	-	N-993	N-997	N-993C	N-997C	-	-
XC 250	11>	11>	-	-	-	N-997	-	N-997C	-	-
XC 300	11>	11>	-	-	-	N-997	-	N-997C	-	-
XC 380	98>	98>	-	-	N-993	N-1073	N-993C	N-1073C	-	-
XC 450 F	08>	08>	-	-	N-993	-	N-993C	-	-	-
XC 505 F	09>	09>	-	-	N-993	-	N-993C	-	-	-
XC-F 250	11>	11>	-	-	-	N-997	-	N-997C	-	-
<b>KYMCO</b>										
ACTIV 110	05>12	05>12	N-941	0304-CP	-	-	-	-	-	-
AGILIT NAKED	15>17	-	N-942	-	-	-	-	-	-	-
AGILITY 125	11>17	-	N-942	-	-	-	-	-	-	-
AGILITY 125 R16 +	15>	-	N-1802	-	-	-	-	-	-	-
AGILITY Carry 125 (4T) EURO4	17>	-	N-1802	-	-	-	-	-	-	-
AGILITY City +125 i CBS	19>	-	N-1802	-	-	-	-	-	-	-
AGILITY CITY E4 125cc	08>	-	N-1802	-	-	-	-	-	-	-
AGILITY DIGITAL	16>17	-	N-942	-	-	-	-	-	-	-
AGILITY MAXI 300i ABS	-	15>	-	N-1820	-	-	-	-	-	-
AGILITY RS	14>17	-	N-942	-	-	-	-	-	-	-
AGILITY XTREME 125	15>17	-	N-942	-	-	-	-	-	-	-
Downtown 200i	10>12	10>12	-	-	N-930	-	N-930C	-	-	-
DOWNTOWN 300	10>14	10>14	-	-	N-930	-	N-930C	-	-	-
Downtown 300i (ABS/C20010)	12>12	12>12	-	-	N-930	-	N-930C	-	-	-
Downtown/Super Dink 125i (C21000)	09>12	09>12	-	-	N-930	-	N-930C	-	-	-
Downtown/Super Dink 300i (V20000)	09>12	09>12	-	-	N-930	-	N-930C	-	-	-
FILLY 50 LX	02>	02>	-	-	N-1075	-	N-1075C	-	-	-
FILLY 50 LX	-	02>	-	0304-CP	-	-	-	-	-	-
FLY 125	13>17	-	-	-	N-942	-	-	-	-	-
HIPSTER 125	08>11	-	-	-	N-940	-	-	-	-	-

K-L-M

Street

Racing

Racing  
Extreme

CUSTOM

### APLICAÇÃO

Ano



APLICAÇÃO	Ano		Street		Racing		Racing Extreme		CUSTOM	
<b>KYMCO</b>										
JETIX 125	10>14	-	-	-	N-941	-	-	-	-	-
JETIX 150	10>	-	-	-	N-941	-	-	-	-	-
LIKE II 125 i CBS	18>	-	-	-	N-1802	-	-	-	-	-
MILER 4T	17>	-	-	-	N-1802	-	-	-	-	-
MX Road 700i	12>	12>	-	-	N-930	-	N-930C	-	-	-
MXU 300 R	-	10>12	-	N-1820	-	-	-	-	-	-
MXU 500i	-	09>12	-	N-1820	-	-	-	-	-	-
NEXXON 125	07>08	-	-	-	N-941	-	-	-	-	-
NEXXON 50	08>09	-	-	-	N-941	-	-	-	-	-
PEOPLE ONE 125i	15>	-	-	-	N-1802	-	-	-	-	-
Pulsar 125 (Luxe)/CK 125 (RJ 25 CB)	99>06	-	-	-	N-941	-	-	-	-	-
ROCKET 125	15>17	-	-	-	N-942	-	-	-	-	-
SPIKE 110	03>08	-	-	-	N-941	-	-	-	-	-
SPIKE 125 R	07>10	-	-	-	N-941	-	-	-	-	-
SUPER 50 9	00>01	00>01	-	-	N-1075	-	N-1075C	-	-	-
TOP BOY	03>06	03>06	-	-	N-1828	-	N-1828C	-	-	-
TOP BOY	97>05	97>05	-	0304-CP	N-942	-	-	-	-	-
TRACK 125	15>17	-	-	-	N-942	-	-	-	-	-
TRACK 125	15>17	15>17	-	0304-CP	N-941	-	-	-	-	-
TWIST 125	17>19	-	-	-	N-942	-	-	-	-	-
UNI K 100	-	14>17	-	0304-CP	-	-	-	-	-	-
VIVIO 125	00>01	00>01	-	0304-CP	N-942	-	-	-	-	-
Xciting 250 05	05>	05>	-	-	N-930	-	N-930C	-	-	-
Xciting 250/250i	05>07	05>07	-	-	N-930	-	N-930C	-	-	-
Xciting 250i 06-08	06>08	06>08	-	-	N-930	-	N-930C	-	-	-
Xciting 300i (T72000) (EFI Model)	08>	08>	-	-	N-930	-	N-930C	-	-	-
Xciting 300i R (T72001/72011)	08>12	08>12	-	-	N-930	-	N-930C	-	-	-
Xciting 500 (T70000) (Carb Model)	05>	05>	-	-	N-930	-	N-930C	-	-	-
Xciting 500 Ri (T70021) (EFI Model)	09>12	09>12	-	-	N-930	-	N-930C	-	-	-
Xciting 500i (T70020) (EFI Model)	06>08	06>08	-	-	N-930	-	N-930C	-	-	-
YUP 50	01>	01>	-	-	N-1075	-	N-1075C	-	-	-
ZX 50 SUPER FEVER	02>	02>	-	-	N-1075	-	N-1075C	-	-	-
<b>LAVERDA</b>										
SFC 1000	04>	04>	-	-	-	N-1818	-	N-1818C	-	-
TTS 800	99>	99>	-	-	-	N-1818	-	N-1818C	-	-
<b>LONGIN</b>										
LX 6 150	02>	02>	-	-	N-970	-	N-970C	-	-	-
<b>MACBOR</b>										
LORD MARTIN 125	18>	-	N-941	-	-	-	-	-	-	-
<b>MOTO-GUZZI</b>										
750 BREVA/NEVADA/NEVADA CLUB	03>	03>	-	-	N-1804	N-1818	N-1804C	N-1818C	-	-
CALIFORNIA 1100 JACKAL	01>	01>	-	-	-	N-934	-	N-934C	-	-
CALIFORNIA 1100 SPECIAL SPORT ALLOY	02>	02>	-	-	-	N-934	-	N-934C	-	-
CALIFORNIA 1100 TITANIUM	03>	03>	-	-	-	N-934	-	N-934C	-	-
GRIESO 1100	05>	05>	-	-	-	N-934	-	N-934C	-	-
MGS-1 1200 CORSA	05>	05>	-	-	-	N-1818	-	N-1818C	-	-
V 1100 BREVA	04>	04>	-	-	N-1804	N-1818	N-1804C	N-1818C	-	-
V BREVA 1100	05>	05>	-	-	-	N-934	-	N-934C	-	-
<b>MOTOMEL</b>										
BIT 110	05>	-	N-941	-	-	-	-	-	-	-
C 110	05>	-	N-941	-	-	-	-	-	-	-
FUSION 110	05>	-	N-941	-	-	-	-	-	-	-
<b>MV AGUSTA</b>										
Brutale , Brutale S 750	01>05	01>05	-	-	-	N-1830	-	N-1830C	-	-
Brutale 1090 R	12>	12>	-	-	N-1804	N-1830	N-1804C	N-1830C	-	-
Brutale 1090 RR	10>	10>	-	-	N-1813	N-1830	N-1813C	N-1830C	-	-
Brutale 675	12>	12>	-	-	N-1804	N-1818	N-1804C	N-1818C	-	-
Brutale 800	13>	13>	-	-	N-1804	N-1818	N-1804C	N-1818C	-	-
Brutale 900 R	10>	10>	-	-	N-1804	N-1830	N-1804C	N-1830C	-	-
Brutale 920	12>	12>	-	-	N-1804	N-1830	N-1804C	N-1830C	-	-

M-P-Q-R-S

Street

Racing

Racing  
Extreme

CUSTOM

APLICAÇÃO

Ano



APLICAÇÃO	Ano	Ano								
<b>MV AGUSTA</b>										
Brutale 989 R	.09	.09	-	-	N-1804	N-1830	N-1804C	N-1830C	-	-
Brutale Corse 1090	14>	14>	-	-	N-1813	N-1830	N-1813C	N-1830C	-	-
Brutale, R, S 910	06>08	06>08	-	-	-	N-1830	-	N-1830C	-	-
F3 675	13>	13>	-	-	N-1804	N-1818	N-1804C	N-1818C	-	-
F3 675	11>12	11>12	-	-	N-1804	N-1830	N-1804C	N-1830C	-	-
F3 800	13>	13>	-	-	N-1813	N-1830	N-1813C	N-1830C	-	-
F4 1000 R	06>07	06>07	-	-	N-1811	N-1830	N-1811C	N-1830C	-	-
F4 1000 R Corsa Corta	12>	12>	-	-	N-1813	N-1830	N-1813C	N-1830C	-	-
F4 1000 RR Corsa Corta	12>	12>	-	-	N-1813	N-1830	N-1813C	N-1830C	-	-
F4 1078 CC, RR	08>11	08>11	-	-	N-1813	N-1830	N-1813C	N-1830C	-	-
F4 750 SPR, F4S	01>	01>	-	-	-	N-1830	-	N-1830C	-	-
Rivale 800	13>	13>	-	-	-	N-1818	-	N-1818C	-	-
<b>PEUGEOT</b>										
SQUAB 50 SCOOTER	-	94>01	-	0304-CP	-	-	-	-	-	-
<b>PGO</b>										
DR 50 BIG	01>	-	N-1800	-	-	-	-	-	-	-
T-REX 50 3	02>	-	N-1800	-	-	-	-	-	-	-
<b>PIAGGIO</b>										
LIBERTY 150	00>02	-	N-940	-	-	-	-	-	-	-
TYPHOON	-	94>95	-	0304-CP	-	-	-	-	-	-
<b>PIAGGIO VESPA</b>										
BEVERLY 500	03>	03>	-	-	N-1818	N-1818	N-1818C	N-1818C	-	-
X8 125	01>03	01>03	-	-	N-1818	N-1818	N-1818C	N-1818C	-	-
X8 200	04>	04>	-	-	-	N-1818	-	N-1818C	-	-
X9 125	01>03	01>03	-	-	N-1818	N-1818	N-1818C	N-1818C	-	-
X9 200	03>	03>	-	-	N-1818	N-1818	N-1818C	N-1818C	-	-
X9 250	00>	00>	-	-	N-1818	N-1818	N-1818C	N-1818C	-	-
X9 500	01>03	01>03	-	-	N-1818	N-1818	N-1818C	N-1818C	-	-
X9 500 EVOLUTION	04>	04>	-	-	N-993	N-1818	N-993C	N-1818C	-	-
X9 500 EVOLUTION ABS	04>	04>	-	-	N-993	N-1818	N-993C	N-1818C	-	-
<b>QINGQI</b>										
QMR 200	08>16	-	N-942	-	-	-	-	-	-	-
<b>ROYAL ENFIELD</b>										
BULLET 500	16>20	-	N-942	-	-	-	-	-	-	-
CLASSIC 350	15>18	15>18	-	-	N-993	-	N-993C	-	-	-
CLASSIC 500	15>18	15>18	-	-	N-993	-	N-993C	-	-	-
CLASSIC 500 ABS	16>20	16>20	-	-	N-993	-	N-993C	-	-	-
CONTINENTAL GT 535	16>17	16>17	-	-	-	N-932	-	N-932C	-	-
HIMALAYAN	19>21	19>21	-	-	N-993	N-932	N-993C	N-932C	-	-
HIMALAYAN 411	15>18	15>18	-	-	N-993	N-932	N-993C	N-932C	-	-
METEOR	2021>	2021>	-	-	N-993	N-932	N-993C	N-932C	-	-
TWIN 650	2019>	2019>	-	-	N-934	N-932	N-934C	N-932C	-	-
<b>SCOMADI</b>										
TL 125	17>	-	N-941	-	-	-	-	-	-	-
<b>SHINERAY</b>										
BIKE 50 - X050QTG11	-	07>	-	0304-CP	-	-	-	-	-	-
DISCOVER 250	07>	07>	N-941	N-940	-	-	-	-	-	-
EXPLORER 150	07>	07>	N-942	N-940	-	-	-	-	-	-
EXPLORER 150 - X150EXP10	07>	07>	N-942	0320-CP	-	-	-	-	-	-
INDIANAPOLIS - XY 200	07>	07>	N-941	N-941	-	-	-	-	-	-
JET 125 +XY	07>	07>	N-941	0304-CP	-	-	-	-	-	-
JET 50	07>	-	N-941	-	-	-	-	-	-	-
LIBERTY 50	07>	07>	N-941	0304-CP	-	-	-	-	-	-
MAX 150 - XY150MAX	07>	07>	N-940	0312-CP	-	-	-	-	-	-
NEW WAVE 125	07>	07>	N-940	0320-CP	-	-	-	-	-	-
PHOENIX + 50 - W050PH011	07>	07>	N-941	0320-CP	-	-	-	-	-	-
PHOENIX 50 - X050PH10	07>	07>	0304-CP	0320-CP	-	-	-	-	-	-
RACING 200 - XY200-5	07>	07>	N-915	N-942	-	-	-	-	-	-

S

**Street**

**Racing**

**Racing  
Extreme**

**CUSTOM**

### APLICAÇÃO

Ano



APLICAÇÃO	Ano		Street		Racing		Racing Extreme		CUSTOM	
<b>SHINERAY</b>										
SPEED 150	-	07>	-	0304-CP	-	-	-	-	-	-
SUPER SMART 50 - X050Q2M	>	>	0304-CP	0320-CP	-	-	-	-	-	-
WAVE 110	-	07>	-	0304-CP	-	-	-	-	-	-
WUYANG 125	07>	-	N-947	-	-	-	-	-	-	-
WUYANG 150	07>	-	N-947	-	-	-	-	-	-	-
X2 250 - X250GY2	99>	99>	N-917	N-943	-	-	-	-	-	-
<b>SIGMA</b>										
SG 125	14>17	-	N-1013	-	-	-	-	-	-	-
SIGMA 100 5A	09>12	-	N-1800	-	-	-	-	-	-	-
<b>SUNDOWN</b>										
ERGON 50	97>	-	N-947	-	-	-	-	-	-	-
FIFTY 50	94>	-	N-1817	-	-	-	-	-	-	-
FUTURE 125	04>	04>	N-906	0301-CP	-	-	-	-	-	-
HUNTER 125	03>	03>	0301-CP	0301-CP	-	-	-	-	-	-
MAX 125 SE	03>	03>	0301-CP	0301-CP	-	-	-	-	-	-
MAX 125 SED	03>	03>	-	-	N-970	-	N-970C	-	-	-
MAX 125 SED	-	03>	-	0301-CP	-	-	-	-	-	-
PGO 50	94>	-	-	-	N-947	-	-	-	-	-
STX 200	07>	07>	-	0301-CP	N-942	-	-	-	-	-
STX 200 MOTARD	07>	07>	-	0301-CP	N-942	-	-	-	-	-
SUPER FIFTY	97>	-	-	-	N-1817	-	-	-	-	-
SUPER FIFTY 50	94>97	-	-	-	N-947	-	-	-	-	-
WEB 100	02>	02>	-	0304-CP	0304-CP	-	-	-	-	-
WEB 100 EVO	06>	06>	-	-	N-1826	-	N-1826C	-	-	-
WEB EVO 100	06>	06>	N-940	0302-CP	-	-	-	-	-	-
WEB NEW 100	04>	04>	0302-CP	0304-CP	-	-	-	-	-	-
<b>SUZUKI</b>										
800 C INTRUDER/M INTRUDER	05>	05>	-	-	N-958	-	N-958C	-	-	-
AH 100	91>01	-	N-947	-	-	-	-	-	-	-
AN 100 SPACE	01>	-	N-947	-	-	-	-	-	-	-
AN 125 BURGMAN i	05>	05>	N-947	0322-CP	-	-	-	-	-	-
AN 125X STAR	04>10	-	N-1800	-	-	-	-	-	-	-
AN 250 BURGMAN	98>00	-	-	-	N-976	-	N-976C	-	-	-
AN 250 BURGMAN	01>06	01>06	-	-	N-976	-	N-976C	-	-	-
AN 250 BURGMAN	-	98>00	-	N-909	-	-	-	-	-	-
AN 400 BURGMAN	99>00	99>00	-	-	N-976	-	N-976C	-	-	-
AN 400 BURGMAN	01>06	01>06	-	-	N-976	-	N-976C	-	-	-
AN 400 BURGMAN	-	99>00	-	N-909	-	-	-	-	-	-
AN 400 BURGMAN	-	01>	-	N-909	-	-	-	-	-	-
AN 400 BURGMAN ( LD )	07>	07>	-	-	N-1828	-	N-1828C	-	-	-
AN 400 BURGMAN ( LE )	07>	07>	-	-	N-1826	-	N-1826C	-	-	-
AN 650 BURGMAN	02>	02>	-	-	N-930	-	N-930C	-	-	-
AN 650 BURGMAN	-	02>	-	N-909	-	-	-	-	-	-
AN 650 BURGMAN EXECUTIVE	04>	04>	-	-	N-930	-	N-930C	-	-	-
ATV OZARK 250	02>06	-	N-906	-	-	-	-	-	-	-
ATV VINSON	03>04	-	N-906	-	-	-	-	-	-	-
AX 4	13>19	13>19	0304-CP	0304-CP	-	-	-	-	-	-
BANDIT 650	07>16	07>16	-	-	N-959	-	N-959C	-	-	-
BANDIT 650	07>16	07>16	-	-	N-958	-	N-958C	-	-	-
BEST 125	08>17	08>17	N-940	0304-CP	-	-	-	-	-	-
B-KING 1300	07>	07>	-	-	-	N-927	-	N-927C	-	-
B-KING 1340	08>	08>	-	-	N-1812	N-984	N-1812C	N-984C	-	-
BURGMAN 400 ABS	09>17	09>17	-	-	N-1828	-	N-1828C	-	-	-
BURGMAN SKYWAVE	07>08	-	N-940	-	-	-	-	-	-	-
C 1500 BOULEVARD (LD)	05>	05>	-	-	N-929	N-929	N-929C	N-929C	-	-
C 1500 INTRUDER	05>	05>	-	-	N-959	-	N-959C	-	-	-
C 1500 INTRUDER (LD)	>	>	-	-	N-929	N-929	N-929C	N-929C	-	-
C 1500 INTRUDER T	13>	13>	-	-	N-930	N-958	N-958C	N-958C	-	-
C 1500 INTRUDER T	13>	13>	-	-	N-958	-	N-930C	-	-	-
C 90 1500 BOULEVARD	05>	05>	-	-	N-958	-	N-958C	-	-	-
C90 1500 BOULEVARD	05>	05>	-	-	N-959	-	N-959C	-	-	-
CR 1800 INTRUDER	08>	08>	-	-	-	N-958	-	N-958C	-	-
DL 1000 V-STROM	14>	14>	-	-	N-983	N-984	N-983C	N-984C	-	-

S

Street

Racing

Racing  
Extreme

CUSTOM

APLICAÇÃO

Ano



APLICAÇÃO	Ano								
<b>SUZUKI</b>									
DL 1000 V-STROM	02>13	02>13	-	-	N-958	-	N-958C	-	-
DL 1000 V-STROM (LD)	02>	02>	-	-	-	N-927	-	N-927C	-
DL 650 V-STROM (LD)	04>	04>	-	-	-	N-927	-	N-927C	-
DL 650 V-STROM ABS	12>	12>	-	-	-	N-927	-	N-927C	-
DR 200	96>16	-	N-906	-	-	-	-	-	-
DR 250	90>93	-	N-942	-	-	-	-	-	-
DR 250	82>94	-	N-906	-	-	-	-	-	-
DR 350	90>00	-	N-942	-	-	-	-	-	-
DR 350 L/M/N/P/R/S	90>	90>	-	-	N-1828	-	N-1828C	-	-
DR 350 S/SH/SL/SM/SN/SP/SR/SE	90>96	90>96	-	-	N-1828	-	N-1828C	-	-
DR 350 V, W, X	97>	97>	-	-	N-991	-	N-991C	-	-
DR 350 V, W, X	-	97>	-	N-946	-	-	-	-	-
DR 650	04>	04>	-	-	N-993	-	N-993C	-	-
DR 650 SE T / W	96>	96>	-	-	N-991	-	N-991C	-	-
DR 650 SE T / W	-	96>	-	N-946	-	-	-	-	-
DR 800 ST BIG	96>	96>	-	-	N-1826	N-1826	N-1826C	N-1826C	-
DR 800 ST BIG	96>	96>	-	-	N-959	-	N-959C	-	-
DR-Z 250	01>	01>	-	-	N-991	N-1075	N-991C	N-1075C	-
DR-Z 250	-	00>	-	N-946	-	-	-	-	-
DR-Z 400 S/E	00>	00>	-	-	N-991	N-1075	N-991C	N-1075C	-
DR-Z 400 SM	05>	05>	-	-	N-991	N-1075	N-991C	N-1075C	-
DR-Z 400 SM	05>	05>	-	-	-	N-1011C	-	-	-
EIGER	02>05	-	N-906	-	-	-	-	-	-
EN 125 YES	04>	04>	-	-	N-1828	-	N-1828C	-	-
EN YES 125	04>	04>	N-942	0321-CP	-	-	-	-	-
EN YES 125 C	09>	09>	N-942	0321-CP	-	-	-	-	-
EN YES 125 SE	12>	12>	N-942	0321-CP	-	-	-	-	-
FW 110 SD	04>07	04>07	N-1788	0304-CP	-	-	-	-	-
GIXXER 150 SF	-	18>19	-	N-1840	-	-	-	-	-
GLADIUS 650	03>11	03>11	-	-	N-958	-	N-958C	-	-
GLADIUS 650	03>11	03>11	-	-	N-959	-	N-959C	-	-
GN 125	03>07	-	N-1013	-	-	-	-	-	-
GN 125 NOVA	17>18	-	N-1013	-	-	-	-	-	-
GS 125	08>	08>	-	-	N-1828	-	N-1828C	-	-
GS 125	07>15	-	N-942	-	-	-	-	-	-
GS 500	04>	04>	-	-	N-958	-	N-958C	-	-
GS 500	96>05	96>05	-	-	N-959	-	N-959C	-	-
GS 500 / GS 500 F	04>	04>	-	-	-	N-924	-	N-924C	-
GS 500 E	96>03	96>03	-	-	N-958	N-924	N-958C	N-924C	-
GS 500 EK/EL/EM/E/ER/ES/ET/EV/EW	89>	89>	-	-	-	N-924	-	N-924C	-
GS 500 F	04>	04>	-	-	N-958	-	N-958C	-	-
GS 750 KATANA / 750 RF	85>	85>	-	-	-	N-924	-	N-924C	-
GSF 1200 BANDIT	.06	.06	-	-	N-929	N-927	N-929C	N-927C	-
GSF 1200 BANDIT	95>96	95>96	-	-	N-956	N-924	N-956C	N-924C	-
GSF 1200 BANDIT	97>00	97>00	-	-	N-957	N-924	N-957C	N-924C	-
GSF 1200 BANDIT	01>05	01>05	-	-	N-922	N-924	N-922C	N-924C	-
GSF 1200 S BANDIT	.06	.06	-	-	N-929	N-927	N-929C	N-927C	-
GSF 1200 S BANDIT	01>05	01>05	-	-	N-922	N-924	N-922C	N-924C	-
GSF 1250 BANDIT ABS	06>	06>	-	-	N-929	N-927	N-929C	N-927C	-
GSF 1250 S BANDIT ABS	06>	06>	-	-	N-929	N-927	N-929C	N-927C	-
GSF 400 Bandit	93>97	93>97	-	-	N-929	N-924	N-929C	N-924C	-
GSF 600 BANDIT / S BANDIT (LD)	00>04	00>04	-	-	-	N-924	-	N-924C	-
GSF 600 BANDIT / S BANDIT (LE)	00>04	00>04	-	-	-	N-924	-	N-924C	-
GSF 600 BANDIT/S BANDIT	00>04	00>04	-	-	N-959	-	N-959C	-	-
GSF 600 BANDIT/S BANDIT	00>04	00>04	-	-	-	-	-	-	-
GSF 600N, BANDIT / S BANDIT	95>99	95>99	-	-	N-930	N-924	N-930C	N-924C	-
GSF 650 BANDIT	07>	07>	-	-	N-929	N-927	N-929C	N-927C	-
GSF 650 BANDIT / S BANDIT (LD)	.05	.05	-	-	-	N-977	-	N-977C	-
GSF 650 BANDIT / S BANDIT (LD)	.06	.06	-	-	-	N-927	-	N-927C	-
GSF 650 BANDIT ABS	07>	07>	-	-	N-929	N-927	N-929C	N-927C	-
GSF 650 BANDIT/S BANDIT	-	05>	-	-	-	-	-	-	N-1621
GSF 650 S BANDIT	07>	07>	-	-	N-929	N-927	N-929C	N-927C	-
GSF 650 S BANDIT ABS	07>	07>	-	-	N-929	N-927	N-929C	N-927C	-
GSR 125	12>	12>	N-942	0321-CP	-	-	-	-	-
GSR 125 S	12>	12>	N-942	0321-CP	-	-	-	-	-
GSR 150 I	12>	12>	N-942	0321-CP	-	-	-	-	-

S

**Street**

**Racing**

**Racing  
Extreme**

**CUSTOM**

APLICAÇÃO	Ano									
<b>SUZUKI</b>										
GSR 600	06>	06>	-	-	N-929	N-984	N-929C	N-984C	-	-
GSR 750	16>17	16>17	-	-	N-959	-	N-959C	-	-	-
GSR 750	16>17	16>17	-	-	N-958	-	N-958C	-	-	-
GSR 750 (LD)	11>	11>	-	-	-	N-927	-	N-927C	-	-
GSRI 150	11>	11>	-	-	N-1828	-	N-1828C	-	-	-
GSX 1000 R	-	01>06	-	-	-	-	-	-	-	N-1621
GSX 1000 R	01>02	01>02	-	-	N-922	-	N-922C	-	-	-
GSX 1000 S	15>	15>	-	-	-	N-962	-	N-962C	-	-
GSX 1000 S F	15>	15>	-	-	-	N-962	-	N-962C	-	-
GSX 1100 G	96>	96>	-	-	N-958	-	N-958C	-	-	-
GSX 1100 G	96>	96>	-	-	N-959	-	N-959C	-	-	-
GSX 1100 G (LD)	96>	96>	-	-	-	N-924	-	N-924C	-	-
GSX 1100 R G/H/J	86>88	86>88	-	-	N-975	-	N-975C	-	-	-
GSX 1200 Inazuma	98>01	98>01	-	-	N-1804	N-924	N-1804C	N-924C	-	-
GSX 1250 FA	10>	10>	-	-	N-929	N-927	N-929C	N-927C	-	-
GSX 1400	-	02>	-	-	-	-	-	-	-	N-1621
GSX 1400	02>	02>	-	-	N-922	N-977	N-922C	N-977C	-	-
GSX 600 R	-	04>05	-	-	-	-	-	-	-	N-1621
GSX 650 F	08>	08>	-	-	N-929	N-927	N-929C	N-927C	-	-
GSX 750 FW	98>02	98>02	-	-	N-959	-	N-959C	-	-	-
GSX 750 FW	98>02	98>02	-	-	N-958	-	N-958C	-	-	-
GSX 750 FW (LD)	98>	98>	-	-	-	N-924	-	N-924C	-	-
GSX 750 KATANA	89>96	89>96	-	-	N-966	N-924	N-966C	N-924C	-	-
GSX 750 R	-	04>05	-	-	-	-	-	-	-	N-1621
GSX R 150	-	18>19	-	N-1840	-	-	-	-	-	-
GSX S 150	-	18>19	-	N-1840	-	-	-	-	-	-
GSX-R 1000	.03	.03	-	-	N-967	N-977	N-967C	N-977C	-	-
GSX-R 1000	04>06	04>06	-	-	N-983	N-977	N-983C	N-977C	-	-
GSX-R 1000	07>08	07>08	-	-	N-983	N-984	N-983C	N-984C	-	-
GSX-R 1000	09>11	09>11	-	-	N-983	N-962	N-983C	N-962C	-	-
GSX-R 1000	12>	12>	-	-	N-1813	N-962	N-1813C	N-962C	-	-
GSX-R 1000 (com ABS)	15>	15>	-	-	-	-	-	N-962C	-	-
GSX-R 1100	89>92	89>92	-	-	N-956	N-924	N-956C	N-924C	-	-
GSX-R 1100	93>97	93>97	-	-	N-922	N-924	N-922C	N-924C	-	-
GSX-R 1100	01>02	01>02	-	-	N-922	N-977	N-922C	N-977C	-	-
GSX-R 1300 HAYABUSA	99>07	99>07	-	-	N-922	N-924	N-922C	N-924C	-	-
GSX-R 1300 HAYABUSA	08>12	08>12	-	-	N-983	N-984	N-983C	N-984C	-	-
GSX-R 1300 HAYABUSA	13>	13>	-	-	N-1813	N-984	N-1813C	N-984C	-	-
GSX-R 600	97>03	97>03	-	-	N-929	N-924	N-929C	N-924C	-	-
GSX-R 600	04>05	04>05	-	-	N-983	N-977	N-983C	N-977C	-	-
GSX-R 600	06>10	06>10	-	-	N-983	N-984	N-983C	N-984C	-	-
GSX-R 600	11>	11>	-	-	N-1813	N-962	N-1813C	N-962C	-	-
GSX-R 750	04>05	04>05	-	-	N-983	N-977	N-983C	N-977C	-	-
GSX-R 750	06>10	06>10	-	-	N-983	N-984	N-983C	N-984C	-	-
GSX-R 750	11>	11>	-	-	N-1813	N-962	N-1813C	N-962C	-	-
GSX-R 750 F	89>91	89>91	-	-	N-956	-	N-956C	-	-	-
GSX-R 750 W	92>93	92>93	-	-	N-956	-	N-956C	-	-	-
GSX-R 750 WR/WS/T/V/W	94>99	94>99	-	-	N-922	N-924	N-922C	N-924C	-	-
GSX-S 1000 ABS	15>	15>	-	-	-	-	-	N-962C	-	-
GSX-S 1000 F ABS	15>	15>	-	-	-	-	-	N-962C	-	-
GW 250 INAZUMA	13>	13>	-	-	N-930	N-1824	N-930C	N-1824C	-	-
INTRUDER 125	02>	02>	N-1013	0321-CP	-	-	-	-	-	-
INTRUDER 150	-	18>20	-	N-1840	-	-	-	-	-	-
INTRUDER 250	-	86>	-	0321-CP	-	-	-	-	-	-
KATANA 125	-	97>	-	0321-CP	-	-	-	-	-	-
LT-A 500 FY QUADMASTER (LE)	00>	00>	-	-	N-1828	-	N-1828C	-	-	-
LT-F 300 KING QUAD (LE)	02>	02>	-	-	N-1828	-	N-1828C	-	-	-
LT-F 500 F	98>	98>	-	-	N-1828	-	N-1828C	-	-	-
LT-F500 FW / FX - LE	98>99		N-942	-	-	-	-	-	-	-
LT-V 7010 QUADRUNNER TWIN PEAKS	04>	04>	-	-	N-1832	N-958	N-1832C	N-958C	-	-
M 1500 R BOULEVARD (LD)	>	>	-	-	-	N-958	-	N-958C	-	-
M 1600 INTRUDER	05>	05>	-	-	N-967	N-958	N-967C	N-958C	-	-
M 1800 R BOULEVARD, INTRUDER	06>	06>	-	-	N-983	N-958	N-983C	N-958C	-	-
M 1800 R2 BOULEVARD, INTRUDER	08>	08>	-	-	N-983	N-958	N-983C	N-958C	-	-
M 800 BOULEVARD	05>	05>	-	-	N-958	-	N-958C	-	-	-
M 800 BOULEVARD	05>	05>	-	-	N-958	-	N-958C	-	-	-

S

Street

Racing

Racing  
Extreme

CUSTOM

APLICAÇÃO

Ano



APLICAÇÃO	Ano		Street		Racing		Racing Extreme		CUSTOM	
<b>SUZUKI</b>										
M 800 INTRUDER	05>	05>	-	-	N-958	-	N-958C	-	-	-
M 800R BOULEVARD	05>	05>	-	-	N-958	-	N-958C	-	-	-
M 95 1600 BOULEVARD	05>06	05>06	-	-	N-958	-	N-958C	-	-	-
RF 600 R	93>96	93>96	-	-	N-930	N-924	N-930C	N-924C	-	-
RF 900 RR	94>97	94>97	-	-	N-957	-	N-957C	-	-	-
RF 900 RS	94>97	94>97	-	-	N-957	-	N-957C	-	-	-
RF 900 RS2	94>97	94>97	-	-	N-957	-	N-957C	-	-	-
RF 900 T	94>97	94>97	-	-	N-957	-	N-957C	-	-	-
RF 900 V	94>97	94>97	-	-	N-957	-	N-957C	-	-	-
RM 100 L	03>	03>	-	-	N-1832	-	N-1832C	-	-	-
RM 125 J	88>	88>	-	-	N-1828	-	N-1828C	-	-	-
RM 125 K - L - M	-	89>95	-	-	-	N-946	-	-	-	-
RM 125 K/L	89>90	89>90	-	-	N-1828	-	N-1828C	-	-	-
RM 125 M/N/P/R/S	91>95	91>95	-	-	N-1828	-	N-1828C	-	-	-
RM 125 T / K	96>04	96>04	-	-	N-991	N-1075	N-991C	N-1075C	-	-
RM 250 H/J	87>88	87>88	-	-	N-1828	-	N-1828C	-	-	-
RM 250 K/L	89>90	89>90	-	-	N-1828	-	N-1828C	-	-	-
RM 250 M/N/P/R/S	91>95	91>95	-	-	N-1828	-	N-1828C	-	-	-
RM 250 T / K	96>04	96>04	-	-	N-991	N-1075	N-991C	N-1075C	-	-
RM 65	03>05	-	-	-	N-906	-	-	-	-	-
RM 85 L	05>	05>	-	-	N-1832	-	N-1832C	-	-	-
RMX 250	91>95	91>95	-	-	N-991	N-991C	-	-	-	-
RMX 250 K/L/M/N/P/R/S	89>95	89>95	-	-	N-1828	N-1828C	-	-	-	-
RMX 250 T / W	96>98	96>98	-	-	N-991	N-991C	-	-	-	-
RMX 250 T / W	-	96>98	-	N-946	-	-	-	-	-	-
RMX 250 X / K1	99>	99>	-	-	N-991	N-1075	N-991C	N-1075C	-	-
RM-Z 250	04>	04>	-	-	N-991	N-991C	-	-	-	-
RM-Z 250	05>	05>	-	-	-	N-1011	-	N-1011C	-	-
RM-Z 250 Efi	10>	10>	-	-	N-991	N-991C	N-1011	N-1011C	-	-
RM-Z 450	05>	05>	-	-	N-991	N-991C	N-1011	N-1011C	-	-
S83 1400 BOULEVARD	05>	05>	-	-	N-975	N-975	N-975C	N-975C	-	-
SFV 650 GLADIUS	09>17	09>17	-	-	N-958	-	N-958C	-	-	-
SFV 650 GLADIUS	09>17	09>17	-	-	N-959	-	N-959C	-	-	-
SFV 650 GLADIUS (LD)	09>	09>	-	-	-	N-1824	-	N-1824C	-	-
SV 1000 S	03>	03>	-	-	-	N-927	-	N-927C	-	-
SV 650 S	03>	03>	-	-	N-958	-	N-958C	-	-	-
SV 650 S	03>	03>	-	-	N-959	-	N-959C	-	-	-
SV 650 S (LD)	03>	03>	-	-	-	N-927	-	N-927C	-	-
TL 1000 RW	98>02	98>02	-	-	N-922	N-924	N-922C	N-924C	-	-
TL 1000 S V-twin	97>01	97>01	-	-	N-929	N-924	N-929C	N-924C	-	-
TS 125	07>09	07>09	-	-	N-1828	-	N-1828C	-	-	-
TS 125	80>07	-	N-942	-	-	-	-	-	-	-
TS 125 CROSS	88>00	-	N-942	-	-	-	-	-	-	-
TS 125 RK	-	89>	-	N-946	-	-	-	-	-	-
TS 125 X	84>88	-	N-942	-	-	-	-	-	-	-
TS 125 X CR	91>95	-	N-942	-	-	-	-	-	-	-
TS 125 Z	93>98	-	N-942	-	-	-	-	-	-	-
TS 125ERC	94>00	94>00	-	-	N-1828	-	N-1828C	-	-	-
TS 125ERCN	90>06	90>06	-	-	N-1828	-	N-1828C	-	-	-
TS 125XC	99>02	99>02	-	-	N-1828	-	N-1828C	-	-	-
TS 200 R	-	90>94	-	N-946	-	-	-	-	-	-
VIVA R 115	15>17	-	N-1788	-	-	-	-	-	-	-
VIVAX 115	99>	-	N-940	-	-	-	-	-	-	-
VL 1500 INTRUDER	02>	02>	-	-	N-959	-	N-959C	-	-	-
VL 1500 INTRUDER LC	98>01	98>01	-	-	N-975	N-975	N-975C	N-975C	-	-
VL 1500 INTRUDER LC (LD)	02	02	-	-	-	N-929	-	N-929C	-	-
VL 800 INTRUDER LC	01>04	01>04	-	-	N-958	-	N-958C	-	-	-
VL 800 INTRUDER LC VOLUSIA	01>04	01>04	-	-	N-958	-	N-958C	-	-	-
VS 1400 INTRUDER LC	87>04	87>04	-	-	N-975	N-975	N-975C	N-975C	-	-
VS 800 INTRUDER	91>99	91>99	-	-	N-975	-	N-975C	-	-	-
V-STROM 1000	07>16	07>16	-	-	N-958	-	N-958C	-	-	-
V-STROM 1000	07>16	07>16	-	-	N-959	-	N-959C	-	-	-
V-STROM 250	17>18	17>18	-	-	N-930	-	N-930C	-	-	-
V-STROM 650	07>17	07>17	-	-	N-958	-	N-958C	-	-	-
V-STROM 650	07>17	07>17	-	-	N-959	-	N-959C	-	-	-
V-STROM 650 DL	04>18	04>18	-	-	N-959	-	N-959C	-	-	-

S-T

**Street**

**Racing**

**Racing  
Extreme**

**CUSTOM**

### APLICAÇÃO

Ano



APLICAÇÃO	Ano		Street		Racing		Racing Extreme		CUSTOM	
<b>SUZUKI</b>										
V-STROM 650 DL	04>18	04>18	-	-	N-958	-	N-958C	-	-	-
VZ 1600 MARAUDER	04	04	-	-	N-922	N-958	N-922C	N-958C	-	-
VZ 800 MARAUDER	97>04	97>04	-	-	N-958	-	N-958C	-	-	-
XF 650 FREEWIND	97>02	97>02	-	-	N-959	-	N-959C	-	-	-
XF 650 V Freewind	97>04	97>04	-	-	N-958	N-1824	N-958C	N-1824C	-	-
<b>SYM</b>										
CITYCOM 125	-	08>13	-	N-1819	-	-	-	-	-	-
CITYCOM 300	15>17		N-1800	-	-	-	-	-	-	-
CROX 125	14>17		N-1800	-	-	-	-	-	-	-
CROX 150	14>17		N-1800	-	-	-	-	-	-	-
FIDDLE 125	14>17	14>17	N-1800	0304-CP	-	-	-	-	-	-
JET 50 EURO	99>00	99>00	N-1800	0304-CP	-	-	-	-	-	-
Joymax 250 i GTS	-	09>15	-	N-1819	-	-	-	-	-	-
Joymax 300 GTS	-	08>15	-	N-1819	-	-	-	-	-	-
Joymax 300 i GTS Sport	-	16>	-	N-1819	-	-	-	-	-	-
Joyride 125 i	-	07>09	-	N-1819	-	-	-	-	-	-
Joyride 200 i	-	07>09	-	N-1819	-	-	-	-	-	-
SPORT BONUS 115 5R	2020	-	N-1800	-	-	-	-	-	-	-
<b>SYM / SANYANG</b>										
ENJOY 50	TODOS	TODOS	0304-CP	0304-CP	-	-	-	-	-	-
PASSING 110	TODOS	TODOS	N-1800	0304-CP	-	-	-	-	-	-
<b>TRAXX</b>										
FLY 125	08>	08>	N-915	N-1013	-	-	-	-	-	-
FLY 135	09>	-	N-1013	-	-	-	-	-	-	-
JOTO 125	08>	-	N-915	-	-	-	-	-	-	-
MOBY/STAR/SKY 50	-	TODOS	-	0320-CP	-	-	-	-	-	-
SKY 110	08>	08>	N-941	0304-CP	-	-	-	-	-	-
SKY 125	08>	08>	N-941	0304-CP	-	-	-	-	-	-
Work 125	10>	-	N-906	-	-	-	-	-	-	-
<b>TRIUMPH</b>										
1000 DAYTONA	91>95	91>95	-	-	N-956	N-1826	N-956C	N-1826C	-	-
1000 TROPHY ( LE)	91>95	91>95	-	-	N-1828	N-1828	N-1828C	N-1828C	-	-
1000 TROPHY (LD)	91>95	91>95	-	-	N-1826	-	N-1826C	-	-	-
1050 SPEED TRIPLE	05>07	05>07	-	-	N-1812	N-1828	N-1812C	N-1828C	-	-
1050 SPEED TRIPLE	08>	08>	-	-	N-1811	N-1828	N-1811C	N-1828C	-	-
1050 SPEED TRIPLE	05>	05>	-	-	N-956	-	N-956C	-	-	-
1050 SPRINT GT ABS	11>	11>	-	-	N-956	N-1828	N-956C	N-1828C	-	-
1050 SPRINT ST	05>	05>	-	-	N-956	N-1828	N-956C	N-1828C	-	-
1050 TIGER	07>	07>	-	-	N-1812	N-1826	N-1812C	N-1826C	-	-
1050 TIGER SE	07>	07>	-	-	N-1812	N-1826	N-1812C	N-1826C	-	-
1200 DAYTONA	91>	91>	-	-	N-956	N-1826	N-956C	N-1826C	-	-
1200 TIGER EXPLORER	12>	12>	-	-	N-956	N-1828	N-956C	N-1828C	-	-
1200 TROPHY	96>03	96>03	-	-	N-956	N-1826	N-956C	N-1826C	-	-
1200 TROPHY	13>	13>	-	-	N-976	N-1828	N-976C	N-1828C	-	-
1200 TROPHY ( LE)	91>95	91>95	-	-	N-1828	N-1828	N-1828C	N-1828C	-	-
1200 TROPHY (LD)	91>95	91>95	-	-	N-1826	-	N-1826C	-	-	-
1600 THUNDERBIRD	09>	09>	-	-	N-956	N-934	N-956C	N-934C	-	-
1700 THUNDERBIRD Commander	14>	14>	-	-	N-956	N-934	N-956C	N-934C	-	-
1700 THUNDERBIRD LT	14>	14>	-	-	N-956	N-934	N-956C	N-934C	-	-
1700 THUNDERBIRD STORM	11>	11>	-	-	N-956	N-934	N-956C	N-934C	-	-
2300 ROCKET III	04>	04>	-	-	N-956	N-934	N-956C	N-934C	-	-
2300 ROCKET III ROADSTER	10>	10>	-	-	N-956	N-934	N-956C	N-934C	-	-
2300 ROCKET III TOURING	13>	13>	-	-	N-956	N-934	N-956C	N-934C	-	-
2300 ROCKET III CLASSIC	07>	07>	-	-	N-956	N-934	N-956C	N-934C	-	-
600 DAYTONA	04>	04>	-	-	N-956	-	N-956C	-	-	-
600 SPEED FOUR	03>	03>	-	-	N-956	N-1824	N-956C	N-1824C	-	-
600 TT	00>03	00>03	-	-	N-956	N-1824	N-956C	N-1824C	-	-
650 DAYTONA	05>	05>	-	-	N-956	N-1824	N-956C	N-1824C	-	-
675 DAYTONA	06>08	06>08	-	-	N-1812	N-1824	N-1812C	N-1824C	-	-
675 DAYTONA TRIPLE	09>12	09>12	-	-	-	N-1824	-	N-1824C	-	-
675 DAYTONA TRIPLE	13>	13>	-	-	-	N-932	-	N-932C	-	-
675 DAYTONA R. TRIPLE	11>12	11>12	-	-	N-1813	N-1824	N-1813C	N-1824C	-	-

T-U

Street

Racing

Racing  
Extreme

CUSTOM

APLICAÇÃO

Ano



APLICAÇÃO	Ano									
<b>TRIUMPH</b>										
675 DAYTONA R. TRIPLE	13>	13>	-	-	N-1813	N-932	N-1813C	N-932C	-	-
675 STREET TRIPLE	08>12	08>12	-	-	N-930	N-1824	N-930C	N-1824C	-	-
675 STREET TRIPLE	13>	13>	-	-	N-930	N-932	N-930C	N-932C	-	-
675 STREET TRIPLE R	09>12	09>12	-	-	N-1812	N-1824	N-1812C	N-1824C	-	-
675 STREET TRIPLE R	13>	13>	-	-	N-1812	N-932	N-1812C	N-932C	-	-
750 TRIDENT (LD)	91>95	91>95	-	-	N-1826	-	N-1826C	-	-	-
750 TRIDENT (LE)	91>95	91>95	-	-	N-1828	N-1828	N-1828C	N-1828C	-	-
800 AMERICA	03>06	03>06	-	-	N-930	N-1828	N-930C	N-1828C	-	-
800 BONNEVILLE	01>04	01>04	-	-	N-930	N-1828	N-930C	N-1828C	-	-
800 BONNEVILLE AMERICA	02>	02>	-	-	N-930	N-1828	N-930C	N-1828C	-	-
800 BONNEVILLE T100	02>08	02>08	-	-	N-930	N-1828	N-930C	N-1828C	-	-
800 SPEEDMASTER	03>	03>	-	-	N-930	N-1828	N-930C	N-1828C	-	-
800 TIGER	11>	11>	-	-	N-930	N-1824	N-930C	N-1824C	-	-
800 TIGER XC	11>	11>	-	-	N-930	N-1824	N-930C	N-1824C	-	-
800 TIGER XC ABS	12>	12>	-	-	N-930	N-1824	N-930C	N-1824C	-	-
800 TIGER XCR/XC/XRX	15>	15>	-	-	N-930	-	N-930C	-	-	-
900 ADVENTURER	96>	96>	-	-	N-930	N-930	N-930C	N-930C	-	-
900 AMERICA	96>	96>	-	-	N-930	N-1828	N-930C	N-1828C	-	-
900 BONNEVILLE	05>08	05>08	-	-	N-930	N-1826	N-930C	N-1826C	-	-
900 BONNEVILLE	09>	09>	-	-	N-930	N-1828	N-930C	N-1828C	-	-
900 BONNEVILLE SE	09>	09>	-	-	N-930	N-1828	N-930C	N-1828C	-	-
900 BONNEVILLE T100	05>08	05>08	-	-	N-930	N-1828	N-930C	N-1828C	-	-
900 BONNEVILLE T100	09>	09>	-	-	N-930	N-1828	N-930C	N-1828C	-	-
900 DAYTONA	91>94	91>94	-	-	N-956	N-1826	N-956C	N-1826C	-	-
900 DAYTONA , SPRINT	94>	94>	-	-	N-956	N-1826	N-956C	N-1826C	-	-
900 DAYTONA SUPER III	94>	94>	-	-	-	N-1826	-	N-1826C	-	-
900 LEGEND TT	99>	99>	-	-	N-930	N-930	N-930C	N-930C	-	-
900 SCRAMBER	06>	06>	-	-	N-930	N-1828	N-930C	N-1828C	-	-
900 SPEED TRIPLE	97>98	97>98	-	-	N-956	N-1828	N-956C	N-1828C	-	-
900 SPEEDMASTER	05>	05>	-	-	N-930	N-1828	N-930C	N-1828C	-	-
900 THRUXTON	04>	04>	-	-	N-930	N-1828	N-930C	N-1828C	-	-
900 THUNDERBIRD	96>	96>	-	-	N-930	N-930	N-930C	N-930C	-	-
900 THUNDERBIRD SPORT	03>	03>	-	-	N-930	N-930	N-930C	N-930C	-	-
900 TIGER	99>00	99>00	-	-	N-930	N-930	N-930C	N-930C	-	-
900 TIGER (LD)	93>98	93>98	-	-	N-1826	N-1828	N-1826C	N-1828C	-	-
900 TIGER (LE)	93>98	93>98	-	-	N-1828	N-1828	N-1828C	N-1828C	-	-
900 TRIDENT (LD)	91>	91>	-	-	N-1826	N-1828	N-1826C	N-1828C	-	-
900 TRIDENT (LE)	91>	91>	-	-	N-1828	N-1828	N-1828C	N-1828C	-	-
900 TROPHY	96>	96>	-	-	N-956	N-1826	N-956C	N-1826C	-	-
900 TROPHY (LE)	91>95	91>95	-	-	N-1828	N-1828	N-1828C	N-1828C	-	-
900 TROPHY (LD)	91>95	91>95	-	-	N-1826	-	N-1826C	-	-	-
950 DAYTONA	96>98	96>98	-	-	N-956	N-1828	N-956C	N-1828C	-	-
950 T 595 DAYTONA	95>98	95>98	-	-	N-956	-	N-956C	-	-	-
955 DAYTONA	99>	99>	-	-	N-956	N-1828	N-956C	N-1828C	-	-
955 DAYTONA CENTENNIAL	02>	02>	-	-	N-956	N-1828	N-956C	N-1828C	-	-
955 SPEED TRIPLE	99>	99>	-	-	N-956	N-1828	N-956C	N-1828C	-	-
955 SPRINT RS	00>	00>	-	-	N-956	N-1828	N-956C	N-1828C	-	-
955 SPRINT ST	99>04	99>04	-	-	N-956	N-1828	N-956C	N-1828C	-	-
955 TIGER	01>04	01>04	-	-	N-930	N-930	N-930C	N-930C	-	-
955 TIGER	04>06	04>06	-	-	N-930	N-1826	N-930C	N-1826C	-	-
ADVENTURER 900	-	96>	-	-	-	N-915	-	-	-	-
DAYTONA 600	04	04	-	-	-	N-1824	-	N-1824C	-	-
LEGEND 900 TT	-	99>	-	-	-	N-915	-	-	-	-
THUNDERBIRD 900	-	96>	-	-	-	N-915	-	-	-	-
THUNDERBIRD 900 SPORT	-	03>	-	-	-	N-915	-	-	-	-
TIGER 800 XCR/XC/XRX	15>	15>	-	-	-	N-1824	-	N-1824C	-	-
TIGER 900	-	99>00	-	N-915	-	-	-	-	-	-
TIGER 955	-	01>	-	N-915	-	-	-	-	-	-
<b>TVS</b>										
ROCKZ	16>17	-	N-940	-	-	-	-	-	-	-
<b>UM</b>										
150 FENIX	05>	-	N-906	-	-	-	-	-	-	-
200 WIND SPEED	05>	-	N-1013	-	-	-	-	-	-	-
DINAMIC	05>	-	N-941	-	-	-	-	-	-	-

U-V-Y

**Street**

**Racing**

**Racing  
Extreme**

**CUSTOM**

### APLICAÇÃO

Ano



APLICAÇÃO	Ano		Street		Racing		Racing Extreme		CUSTOM	
<b>UM</b>										
DSF 200	07>10	-	N-942	-	-	-	-	-	-	-
DSR 200	11>16	-	N-942	-	-	-	-	-	-	-
FASTWIND 200 R	08>11	-	N-941	-	-	-	-	-	-	-
GP1 125	05>09	-	N-942	-	-	-	-	-	-	-
GP1 125 POWERMAX	04>	04>	-	-	N-1828	-	N-1828C	-	-	-
GP1 150	06>09	-	N-942	-	-	-	-	-	-	-
MAGNETIC 125	06>10	-	N-1013	-	-	-	-	-	-	-
MAX 125 R	08>11	-	N-1013	-	-	-	-	-	-	-
NITROX 125 R	09>13	09>13	0302-CP	0302-CP	-	-	-	-	-	-
POWER MAX 125 GPI	06>11	06>11	N-942	N-942	-	-	-	-	-	-
REV 180 R	10>11	-	N-1013	-	-	-	-	-	-	-
SMF ENDURO 150	06>09	-	N-941	-	-	-	-	-	-	-
STREET 200	10>	10>	N-941	N-941	-	-	-	-	-	-
V2S 250 R	-	09>17	-	N-941	-	-	-	-	-	-
V2S 650 R	-	09>11	-	N-941	-	-	-	-	-	-
VENUS 115 R	10>16	-	N-941	-	-	-	-	-	-	-
XTREET 200	11>13	-	N-941	-	-	-	-	-	-	-
<b>VESPA</b>										
MEDLEY 150	16>18	-	N-1834	-	-	-	-	-	-	-
<b>VICTORY</b>										
MRX 125	16>17	-	N-941	-	-	-	-	-	-	-
MXR 150	16>17	-	N-941	-	-	-	-	-	-	-
ONE 100	17>	-	N-941	-	-	-	-	-	-	-
<b>YAMAHA</b>										
125 D'elight	18>	-	N-1880	-	-	-	-	-	-	-
1600 A WILD STAR	99>	99>	-	-	-	N-987	-	N-987C	-	-
AT 115	06>	-	N-954	-	-	-	-	-	-	-
Axis 90	90>	90>	N-1817	0308-CP	-	-	-	-	-	-
BT 1100 BULLDOG	02>	02>	-	-	N-925	N-980	N-925C	N-980C	-	-
BW'S	93>	93>	0308-CP	0308-CP	-	-	-	-	-	-
Crypton 105	98>05	98>05	0308-CP	0308-CP	-	-	-	-	-	-
CRYPTON 105	-	10>	-	0301-CP	-	-	-	-	-	-
CRYPTON 105 (MÉXICO)	99>05	-	N-954	-	-	-	-	-	-	-
CRYPTON 110 ED	14>17	-	N-954	-	-	-	-	-	-	-
CRYPTON FI 150	17>18	-	N-1880	-	-	-	-	-	-	-
Crypton T 115 ED	10>	10>	N-951	0323-CP	-	-	-	-	-	-
Crypton T 115 K	10>	10>	0308-CP	0323-CP	-	-	-	-	-	-
CRYPTON T135	06>	-	N-951	-	-	-	-	-	-	-
CR-Z 50 (3WN)	91>95	-	N-1817	-	-	-	-	-	-	-
CY 50 RS Jog R	96>	-	N-1817	-	-	-	-	-	-	-
DT 125 D / DS	96>07	-	N-954	-	-	-	-	-	-	-
DT 125 X	05>06	05>06	-	-	N-934	-	N-934C	-	-	-
DT 175 D	00>07	-	N-954	-	-	-	-	-	-	-
DT 180	>87	-	0307-CP	-	-	-	-	-	-	-
DT 180	82>87	82>87	0301-CP	0301-CP	-	-	-	-	-	-
DT 180	-	>87	-	0307-CP	-	-	-	-	-	-
DT 180	-	93>	-	0301-CP	-	-	-	-	-	-
DT 180 Z	-	88>92	-	0301-CP	-	-	-	-	-	-
DT 180, TDR 180	93>	93>	N-919	0307-CP	-	-	-	-	-	-
DT 200	91>	91>	N-919	0307-CP	-	-	-	-	-	-
DT 200	-	93>	-	0301-CP	-	-	-	-	-	-
DT 200 R	>95	>95	N-919	N-919	-	-	-	-	-	-
DT 200 R	95>	95>	N-919	0307-CP	-	-	-	-	-	-
DT 200 WR	-	91>	-	N-946	-	-	-	-	-	-
DTZ, TDR 180	88>92	88>	N-913	0307-CP	-	-	-	-	-	-
EXCITER 135/150	15>	-	N-1880	-	-	-	-	-	-	-
FACTOR 150 ED/ESD	-	14>	-	0301-CP	-	-	-	-	-	-
FAZER 150	19>20	19>20	-	-	N-993	-	N-993C	-	-	-
FAZER 16	11>15	11>15	-	-	N-993	-	N-993C	-	-	-
FAZER 250	04>15	04>15	-	-	N-1826	-	N-1826C	-	-	-
FAZER 600 FZS	-	98>03	-	N-910	-	-	-	-	-	-
FAZER 600 FZS S	-	01>03	-	N-910	-	-	-	-	-	-
Fazer YS 150 ED	13>	13>	N-951	0323-CP	-	-	-	-	-	-

Y

Street

Racing

Racing  
Extreme

CUSTOM

APLICAÇÃO

Ano



APLICAÇÃO	Ano								
<b>YAMAHA</b>									
FAZER YS 150 ED	16>	-	N-1788	-	-	-	-	-	-
Fazer YS 150 SED	13>	13>	N-951	0323-CP	-	-	-	-	-
FAZER YS 150 SED	16>	-	N-1788	-	-	-	-	-	-
Fazer YS 250	05>	05>	N-940	0323-CP	-	-	-	-	-
Fazer YS 250	-	11>	-	N-946	-	-	-	-	-
Fazer YS 250 BlueFlex	12>15	12>15	N-940	N-946	-	-	-	-	-
FAZER YS 250	16>	-	N-949	-	-	-	-	-	-
FINO AF 115 S	12>14	-	N-951	-	-	-	-	-	-
FJ 1200 ABS	91>93	91>93	-	-	N-987	N-980	N-987C	N-980C	-
FJR 1300	01>	01>	-	-	N-925	N-1805	N-925C	N-1805C	-
FJR 1300 A, AS	13>	13>	-	-	N-976	N-1805	N-976C	N-1805C	-
FJR 1300 ABS	03>05	03>05	-	-	N-925	N-1805	N-925C	N-1805C	-
FJR 1300 ABS	06>12	06>12	-	-	N-976	N-1805	N-976C	N-1805C	-
FZ 16	11>15	11>15	-	-	N-993	-	N-993C	-	-
FZ 16 2.0	15>18	15>18	-	-	N-993	-	N-993C	-	-
FZ 25	18>	18>	-	-	N-993	-	N-993C	-	-
FZ 750 GENESIS	87>88	87>88	-	-	N-980	N-980	N-980C	N-980C	-
FZ 750 GENESIS	89>92	89>92	-	-	N-987	N-980	N-987C	N-980C	-
FZ1 1000 FAZER	06>	06>	-	-	N-925	N-927	N-925C	N-927C	-
FZ6 600 FAZER	04>	04>	-	-	N-970	N-927	N-970C	N-927C	-
FZ6 600 S2	07>	07>	-	-	N-925	N-927	N-925C	N-927C	-
FZ6 600 S2 ABS	07>	07>	-	-	N-925	N-927	N-925C	N-927C	-
FZ6 600 S2 FAZER	07>	07>	-	-	N-925	N-927	N-925C	N-927C	-
FZ6 R 600	09>	09>	-	-	N-970	N-1824	N-970C	N-1824C	-
FZR 1000	94>95	94>95	-	-	-	N-980	-	N-980C	-
FZR 1000 EX UP	90>91	90>91	-	-	N-986	N-980	N-986C	N-980C	-
FZR 1000 GENESIS	87>89	87>89	-	-	-	N-980	-	N-980C	-
FZR 600 R	90>91	90>91	-	-	N-986	N-980	N-986C	N-980C	-
FZR 600 R	-	92>95	-	-	-	N-980	-	N-980C	-
FZR 600 R	.89	.89	-	-	N-980	N-980	N-980C	N-980C	-
FZR 750 R	89>90	89>90	-	-	N-956	N-980	N-956C	N-980C	-
FZR 750 R GENESIS	87>88	87>88	-	-	-	N-980	-	N-980C	-
FZX 700 FAZER	87>	87>	-	-	N-980	N-980	N-980C	N-980C	-
FZX 750 FAZER	86>	86>	-	-	N-980	N-980	N-980C	N-980C	-
GDR125RI	17>	-	-	-	N-1880	-	-	-	-
GPD125-A	16>	-	-	-	N-1880	-	-	-	-
GRAN AXIS 100	98>03	-	-	-	N-1817	-	-	-	-
Jog 50	-	93>	-	-	-	0308-CP	-	-	-
Jog 90	90>	-	-	-	N-1817	-	-	-	-
JUPITER MX	16>	-	-	-	N-1880	-	-	-	-
LIBERO 125	10>13	-	-	-	N-951	-	-	-	-
MT 01 1700	05>06	05>06	-	-	N-925	N-930	N-925C	N-930C	-
MT 01 1700	07>	07>	-	-	N-978	N-930	N-978C	N-930C	-
MT 07 700	14>	14>	-	-	N-925	N-927	N-925C	N-927C	-
MT 07 700 ABS	14>	14>	-	-	N-925	N-927	N-925C	N-927C	-
MT 09 850	13>	13>	-	-	N-925	N-927	N-925C	N-927C	-
MT 09 850 ABS	13>	13>	-	-	N-925	N-927	N-925C	N-927C	-
MT-03	16>	16>	-	-	-	N-1878	-	-	-
MT-03 321	16>	16>	-	-	N-1876	-	-	-	-
MT-03 321	-	16>	-	N-951	-	-	-	-	-
MT-03 660	06>	06>	-	-	N-970	N-932	N-970C	N-932C	-
MT-03 660	06>	06>	-	-	-	N-1073	-	N-1073C	-
N MAX 150	17>18	17>18	N-1880	N-951	-	-	-	-	-
NEO 115 AT	04>	04>	N-954	0323-CP	-	-	-	-	-
NEO 125 UBS	19>	19>	N-1788	0323-CP	-	-	-	-	-
NEXT 115	08>10	-	N-954	-	-	-	-	-	-
NMAX 160 C/ ABS	17>	17>	N-1880	N-951	-	-	-	-	-
R 15 V3	19>20	19>20	-	-	N-993	-	N-993C	-	-
R1 1000	98>01	98>01	-	-	-	N-972	-	N-972C	-
R3 321	-	15>	-	N-951	-	-	-	-	-
RD 125	86>92	86>92	0301-CP	0301-CP	-	-	-	-	-
RD 125 Z	-	83>92	-	0301-CP	-	-	-	-	-
RD 125, RX 180	>87	>87	0307-CP	0307-CP	-	-	-	-	-
RD 135	87>	87>	0307-CP	0307-CP	-	-	-	-	-
RD 135	93>	93>	0301-CP	0301-CP	-	-	-	-	-
RD 135 Z	-	93>	-	0301-CP	-	-	-	-	-

Y

**Street**

**Racing**

**Racing  
Extreme**

**CUSTOM**

### APLICAÇÃO

Ano



APLICAÇÃO	Ano		Street		Racing		Racing Extreme		CUSTOM	
	1	2	1	2	1	2	1	2	1	2
<b>YAMAHA</b>										
RD 350 LC	87>	87>	N-910	N-910	-	-	-	-	-	-
RD 350 LC YPVS	83>84	83>84	-	-	-	N-980	-	N-980C	-	-
RD 350 LC YPVS	83>84	-	N-901	-	-	-	-	-	-	-
RD 350 R	91>	91>	N-910	N-910	-	-	-	-	-	-
RD 350 R	-	-	-	-	-	-	-	-	-	-
RDZ 125, RDZ II 125	todos	87>	N-901	0307-CP	-	-	-	-	-	-
RDZ 135	todos	87>	N-901	0307-CP	-	-	-	-	-	-
RHINO 660 (LE)	05>	05>	-	-	N-1828	-	N-1828C	-	-	-
RT 180 A,B,D	90>92	-	N-913	-	-	-	-	-	-	-
RT 180 E	93	-	N-913	-	-	-	-	-	-	-
RX 125	79>84	79>84	0301-CP	0301-CP	-	-	-	-	-	-
RX 180 AVANT	81>83	81>83	0301-CP	0301-CP	-	-	-	-	-	-
RX 180 Custom	todos	87>	N-901	0307-CP	-	-	-	-	-	-
RX 180 CUSTOM	todos	80>83	N-901	0301-CP	-	-	-	-	-	-
SEROW 250 (3C51/52)	-	05>	-	N-946	-	-	-	-	-	-
SR 125	92>96	-	N-901	-	-	-	-	-	-	-
SZ 16 R	13>15	13>15	-	-	N-993	-	N-993C	-	-	-
T 105E	99>	-	N-954	-	-	-	-	-	-	-
TDM 900	02>13	02>13	-	-	N-925	N-1805	N-925C	N-1805C	-	-
TDM 900 A ABS	05>13	05>13	-	-	N-925	N-1805	N-925C	N-1805C	-	-
TDM 225	97>	97>	N-919	0301-CP	-	-	-	-	-	-
TDM 225	-	97>	-	0307-CP	-	-	-	-	-	-
TDM 850	91>95	91>95	-	-	N-987	N-980	N-987C	N-980C	-	-
TDM 850	96>01	96>01	-	-	N-986	N-980	N-986C	N-980C	-	-
TDR 180	88>92	88>92	N-913	0301-CP	-	-	-	-	-	-
Tricity 155 ABS	18>	-	N-951	-	-	-	-	-	-	-
TT 125	-	79>84	-	0301-CP	-	-	-	-	-	-
TT 125 e 80cc	>84	>84	0307-CP	0307-CP	-	-	-	-	-	-
TT 250 R	-	93>99	-	N-946	-	-	-	-	-	-
TT 600	89>	93>	N-913	N-946	-	-	-	-	-	-
TT-R 125	-	00>	-	0308-CP	-	-	-	-	-	-
TT-R 230	05>	05>	-	-	N-1828	-	N-1828C	-	-	-
TT-R 230	-	05>	-	0301-CP	-	-	-	-	-	-
VITY 125	08>	-	N-951	-	-	-	-	-	-	-
V-MAX 1200	93>	93>	-	-	N-986	N-980	N-986C	N-980C	-	-
V-MAX 1200	85>92	85>92	-	-	N-980	N-980	N-980C	N-980C	-	-
V-MAX 1700	09>	09>	-	-	N-978	N-1805	N-978C	N-1805C	-	-
WR 125	91>97	91>97	-	-	N-1828	N-1075	N-1828C	N-1075C	-	-
WR 125	98>02	98>02	-	-	N-991	N-1075	N-991C	N-1075C	-	-
WR 125	91>97	-	N-942	-	-	-	-	-	-	-
WR 125	-	90>92	-	N-946	-	-	-	-	-	-
WR 200	92>97	92>97	-	-	N-1828	-	N-1828C	-	-	-
WR 200	91>92	91>92	-	-	N-1828	-	N-1828C	-	-	-
WR 200 B	-	91>94	-	N-946	-	-	-	-	-	-
WR 250	92>97	92>97	-	-	N-1828	N-1075	N-1828C	N-1075C	-	-
WR 250	98>02	98>02	-	-	N-991	N-1075	N-991C	N-1075C	-	-
WR 250	90>	90>	-	-	N-1828	-	N-1828C	-	-	-
WR 250 (Z 2T)	-	91>97	-	N-946	-	-	-	-	-	-
WR 250 F	01>02	01>02	-	-	N-991	N-1075	N-991C	N-1075C	-	-
WR 250 F	03>	03>	-	-	N-991	N-1011	N-991C	N-1011C	-	-
WR 250 F	91>97	-	N-942	-	-	-	-	-	-	-
WR 250 F	-	17>18	-	N-954	-	-	-	-	-	-
WR 250 F Efi	15>	15>	-	-	N-1838	N-1011	N-1838C	N-1011C	-	-
WR 250 X	08>17	08>17	-	-	N-930	-	N-930C	-	-	-
WR 250 ZB	91>	91>	-	-	N-1828	-	N-1828C	-	-	-
WR 250 ZD/ZE/ZF/ZG/ZH/ZJ/R	92>97	92>97	-	-	N-1828	-	N-1828C	-	-	-
WR 400 F	98>00	99>00	-	-	N-991	N-1075	N-991C	N-1075C	-	-
WR 400 F	-	98>	-	N-946	-	-	-	-	-	-
WR 426 F	01>02	01>02	-	-	N-991	N-1075	N-991C	N-1075C	-	-
WR 450 F	03>	03>	-	-	N-991	N-1011	N-991C	N-1011C	-	-
WR 500 B	91>	91>	-	-	N-1828	-	N-1828C	-	-	-
WR 500 B	-	91>	-	N-919	-	-	-	-	-	-
WR 500 ZD/ZE	92>93	92>93	-	-	N-1828	-	N-1828C	-	-	-
X CITY 250	07>17	07>17	-	-	N-930	-	N-930C	-	-	-
X CITY 250	-	07>17	-	N-954	-	-	-	-	-	-
X MAX 250	08>09	-	N-954	-	-	-	-	-	-	-

Y

Street

Racing

Racing  
Extreme

CUSTOM

APLICAÇÃO

Ano



APLICAÇÃO	Ano		Street		Racing		Racing Extreme		CUSTOM	
<b>YAMAHA</b>										
XG 250	10>17	-	N-954	-	-	-	-	-	-	-
XJ 600	83>91	83>91	-	-	N-980	N-980	N-980C	N-980C	-	-
XJ 600 N	91>97	91>97	-	-	N-970	-	N-970C	-	-	-
XJ 600 N	98>	98>	-	-	N-970	-	N-970C	-	-	-
XJ 600 N	-	91>97	-	N-910	-	-	-	-	-	-
XJ 600 N	-	98>	-	N-910	-	-	-	-	-	-
XJ 600 S DIVERSION	91>97	91>97	-	-	N-971	-	N-971C	-	-	-
XJ 600 S DIVERSION	98>03	98>03	-	-	N-970	-	N-970C	-	-	-
XJ 600 S DIVERSION	-	91>97	-	N-910	-	-	-	-	-	-
XJ 600 S DIVERSION	-	98>03	-	N-910	-	-	-	-	-	-
XJ 900 , F	83>94	83>94	-	-	N-980	N-980	N-980C	N-980C	-	-
XJ 900 S DIVERSION	95>03	95>03	-	-	N-971	N-980	N-971C	N-980C	-	-
XJ6-F 600 DIVERSION	13>	13>	-	-	N-970	N-927	N-970C	N-927C	-	-
XJ6-F 600 DIVERSION ABS	10>12	10>12	-	-	N-970	N-1824	N-970C	N-1824C	-	-
XJ6-F 600 DIVERSION ABS	13>	13>	-	-	N-970	N-927	N-970C	N-927C	-	-
XJ6-N 600 DIVERSION	09>12	09>12	-	-	N-970	N-1824	N-970C	N-1824C	-	-
XJ6-N 600 DIVERSION	13>	13>	-	-	N-970	N-927	N-970C	N-927C	-	-
XJ6-N 600 DIVERSION ABS	09>12	09>12	-	-	N-970	N-1824	N-970C	N-1824C	-	-
XJ6-N 600 DIVERSION ABS	13>	13>	-	-	N-970	N-927	N-970C	N-927C	-	-
XJ6-N SP 600 DIVERSION	13>	13>	-	-	N-970	N-927	N-970C	N-927C	-	-
XJ6-N SP 600 DIVERSION ABS	13>	13>	-	-	N-970	N-927	N-970C	N-927C	-	-
XJ6-S 600 DIVERSION	09>12	09>12	-	-	N-970	N-1824	N-970C	N-1824C	-	-
XJ6-S 600 DIVERSION	13>	13>	-	-	N-970	N-927	N-970C	N-927C	-	-
XJ6-S 600 DIVERSION ABS	09>12	09>12	-	-	N-970	N-1824	N-970C	N-1824C	-	-
XJ6-S 600 DIVERSION ABS	13>	13>	-	-	N-970	N-927	N-970C	N-927C	-	-
X-Max 125 ABS	18>	18>	-	-	N-1876	N-1878	-	-	-	-
X-Max 300 ABS	17>	17>	-	-	N-1876	N-1878	-	-	-	-
X-Max 300 Iron Max	19>	19>	-	-	N-1876	-	-	-	-	-
XP 500 T-MAX	08>12	08>12	-	-	N-925	-	N-925C	-	-	-
XP 500 T-MAX ABS	08>12	08>12	-	-	N-925	-	N-925C	-	-	-
XP 530 BLACK-MAX	13>	13>	-	-	N-925	N-1805	N-925C	N-1805C	-	-
XP 530 T-MAX	12>	12>	-	-	N-925	N-1805	N-925C	N-1805C	-	-
XP 530 T-MAX ABS	12>	12>	-	-	N-925	N-1805	N-925C	N-1805C	-	-
XT 1200 Z Super Ténéré	10>	10>	-	-	N-925	N-1805	N-925C	N-1805C	-	-
XT 225	02>	02>	N-919	0301-CP	-	-	-	-	-	-
XT 225	00>08	97>	N-954	0301-CP	-	-	-	-	-	-
XT 250 X	06>17	-	N-954	-	-	-	-	-	-	-
XT 350	85>	-	N-919	-	-	-	-	-	-	-
XT 600 E	90>	90>	-	-	N-1791	-	N-1791C	-	-	-
XT 600 E	-	90>	-	N-919	-	-	-	-	-	-
XT 600 Ténéré	88>92	88>92	N-913	0303-CP	-	-	-	-	-	-
XT 600 X	04>	04>	-	-	-	N-1073	-	N-1073C	-	-
XT 600 Z TÉNÉRÉ	-	87>	-	N-919	-	-	-	-	-	-
XT 660 R	04>	04>	-	-	N-934	N-932	N-934C	N-932C	-	-
XT 660 R	04>	04>	-	-	-	N-1073	-	N-1073C	-	-
XT 660 R	04>15	04>15	-	-	-	N-932	-	N-932C	-	-
XT 660 R	05>	05>	-	-	-	N-1073	-	N-1073C	-	-
XT 660 Z Ténéré	12>	12>	-	-	-	N-932	-	N-932C	-	-
XT Z 125 E / K	02>	02>	N-942	0301-CP	-	-	-	-	-	-
XT Z 125X E	02>	02>	N-942	0301-CP	-	-	-	-	-	-
XT Z 250 Ténéré	11>	11>	N-942	N-946	-	-	-	-	-	-
XT Z 600	86>	-	N-913	-	-	-	-	-	-	-
XT Z 600 TÉNÉRÉ	87>93	-	N-913	-	-	-	-	-	-	-
XT Z 660 TÉNÉRÉ	08>	08>	-	-	-	N-1073	-	N-1073C	-	-
XT Z 660 TÉNÉRÉ ABS	11>	11>	-	-	-	N-1073	-	N-1073C	-	-
XTR 660 TENERE	08>16	08>16	-	-	-	N-932	-	N-932C	-	-
XTX 660	04>	04>	-	-	N-1804	-	N-1804C	-	-	-
XTZ 125	02>	02>	-	-	N-1828	-	N-1828C	-	-	-
XTZ 125	-	02>	-	0301-CP	-	-	-	-	-	-
XTZ 125 E	15>17	15>17	N-942	0301-CP	-	-	-	-	-	-
XTZ 125 K	06>15	-	N-942	-	-	-	-	-	-	-
XTZ 150 ED	-	15>	-	0301-CP	-	-	-	-	-	-
XTZ 250	05>16	-	N-942	-	-	-	-	-	-	-
XTZ 250 LANDER	07>	07>	-	-	N-1828	-	N-1828C	-	-	-
XTZ 250 LANDER	06>	06>	N-942	N-946	-	-	-	-	-	-
XTZ 250 LANDER	16>	-	N-1834	-	-	-	-	-	-	-

Y

**Street**

**Racing**

**Racing  
Extreme**

**CUSTOM**

### APLICAÇÃO

Ano



APLICAÇÃO	Ano		Street		Racing		Racing Extreme		CUSTOM	
<b>YAMAHA</b>										
XTZ 250 TENERE	16>	-	N-1834	-	-	-	-	-	-	-
XTZ 250 TÉNÉRÉ	11>15	11>15	-	-	N-1828	-	N-1828C	-	-	-
XTZ 250 X	08>	08>	-	-	N-1828	-	N-1828C	-	-	-
XTZ 250 X	06>	06>	N-942	N-946	-	-	-	-	-	-
XTZ 660 "Tenere"	91>98	91>98	-	-	N-1791	-	N-1791C	-	-	-
XTZ 660 TÉNÉRÉ	08>	08>	-	-	N-993	-	N-993C	-	-	-
XTZ 660 TÉNÉRÉ	-	91>98	-	N-919	-	-	-	-	-	-
XTZ 660 TÉNÉRÉ ABS	11>	11>	-	-	N-993	-	N-993C	-	-	-
XTZ 750 Super Ténéré ( LD )	88>	93>98	-	-	N-1826	N-1826	N-1826C	N-1826C	-	-
XTZ 750 Super Ténéré ( LE )	88>	88>	-	-	N-1828	-	N-1828C	-	-	-
XTZ CROSSER 150 E	14>	14>	0323-CP	0323-CP	-	-	-	-	-	-
XTZ CROSSER 150 ED	14>	14>	N-1834	0323-CP	-	-	-	-	-	-
XV 1100	94>97	94>97	-	-	N-980	-	N-980C	-	-	-
XV 1100 VIRAGO	86>93	86>93	-	-	N-980	-	N-980C	-	-	-
XV 1000	84>	84>	-	-	N-980	N-980	N-980C	N-980C	-	-
XV 1100	94>97	94>97	-	-	N-980	-	N-980C	-	-	-
XV 1100 VIRAGO	86>93	86>93	-	-	N-980	-	N-980C	-	-	-
XV 1100 VIRAGO	94>98	94>98	-	-	N-971	-	N-971C	-	-	-
XV 1200 VENTURE ROYALE, DL, DC2	85>	85>	-	-	N-980	N-980	N-980C	N-980C	-	-
XV 1600 A WILD STAR	99>	99>	-	-	N-971	-	N-971C	-	-	-
XV 1700 PC ROAD STAR WARRIOR	03>	03>	-	-	N-925	N-1805	N-925C	N-1805C	-	-
XV 1700 PC ROAD STAR WARRIOR	03>	03>	-	-	-	N-987	-	N-987C	-	-
XV 1700 ROAD STAR WARRIOR	.02	.02	-	-	N-925	N-987	N-925C	N-987C	-	-
XV 250 Virago	95>	95>	-	-	N-970	-	N-970C	-	-	-
XV 250 Virago	-	89>	-	-	-	0301-CP	-	-	-	-
XV 250 VIRAGO	-	89>94	-	-	-	0301-CP	-	-	-	-
XV 250 VIRAGO	-	95>	-	-	-	0301-CP	-	-	-	-
XV 250 VIRAGO ROUTE 66	95>97	95>97	-	-	N-970	-	N-970C	-	-	-
XV 535 DX VIRAGO	98>03	98>03	-	-	N-971	-	N-971C	-	-	-
XV 535 S VIRAGO	96>03	96>03	-	-	N-971	-	N-971C	-	-	-
XV 535 VIRAGO	95>97	95>97	-	-	N-971	-	N-971C	-	-	-
XV 700 VIRAGO	87>	87>	-	-	N-980	-	N-980C	-	-	-
XV 750 VIRAGO	94>	94>	-	-	N-971	-	N-971C	-	-	-
XV 920 VIRAGO	81>	81>	-	-	-	N-980	-	N-980C	-	-
XV 920 VIRAGO	-	83>	-	N-901	-	-	-	-	-	-
XV S 250 Virago	95>	95>	-	-	N-970	-	N-970C	-	-	-
XV S 250 Virago	-	95>	-	0301-CP	-	-	-	-	-	-
XVS 1100 V- STAR	99>	99>	-	-	N-970	N-980	N-970C	N-980C	-	-
XVS 1100 V-STAR CLASSIC	00>	00>	-	-	N-970	N-980	N-970C	N-980C	-	-
XVS 1300 A Midnight Star	07>	07>	-	-	N-970	N-1805	N-970C	N-1805C	-	-
XVS 1300 STRYKER	11>	07>	-	-	N-971	N-1805	N-971C	N-1805C	-	-
XVS 1900 A Midnight Star	06>	06>	-	-	N-925	N-1805	N-925C	N-1805C	-	-
XVS 250 DRAG STAR	01>	01>	-	-	N-970	-	N-970C	-	-	-
XVS 250 DRAG STAR	-	01>	-	0301-CP	-	-	-	-	-	-
XVS 650 A DRAG STAR CLASSIC	98>	98>	-	-	N-971	-	N-971C	-	-	-
XVS 650 DRAG STAR	98>	98>	-	-	N-971	-	N-971C	-	-	-
XVS 950 A MIDNIGHT STAR	09>	09>	-	-	N-971	N-1805	N-971C	N-1805C	-	-
XVS 950 BOLT	14>	14>	-	-	N-971	N-1805	N-971C	N-1805C	-	-
XVZ 1300 ROYAL STAR BOULEVARD	99>	99>	-	-	N-987	N-987	N-987C	N-987C	-	-
XVZ 1300 ROYAL STAR TOUR CLASSIC	97>	97>	-	-	-	N-987	-	N-987C	-	-
XVZ 1300 TF ROYAL STAR BOULEVARD	99>	99>	-	-	N-971	N-987	N-971C	N-987C	-	-
YA 50 ZA Jog	95>	-	N-1817	-	-	-	-	-	-	-
YBR 125 D	98>01	-	N-954	-	-	-	-	-	-	-
YBR 125 DX	07>08	07>08	-	-	N-993	-	N-993C	-	-	-
YBR 125 E / K	00>	00>	0301-CP	0301-CP	-	-	-	-	-	-
YBR 125 ED	01>08	01>08	-	-	N-1826	-	N-1826C	-	-	-
YBR 125 ED	00>	-	N-940	-	-	-	-	-	-	-
YBR 125 ED	13>15	01>08	N-951	0301-CP	-	-	-	-	-	-
YBR 125 ESD	13>15	-	N-951	-	-	-	-	-	-	-
YBR 125 FACTOR	09>	09>	N-951	0323-CP	-	-	-	-	-	-
YBR 125 K/E	99>	99>	0301-CP	0301-CP	-	-	-	-	-	-
YBR 125 K/E	-	-	-	-	-	-	-	-	-	-
YBR 125 SS	08>10	08>10	-	-	N-993	-	N-993C	-	-	-
YBR 125 ZR	13>19	-	N-951	-	-	-	-	-	-	-
YBR 150 FACTOR E	16>	16>	0323-CP	0323-CP	-	-	-	-	-	-
YBR 150 FACTOR ED	16>	16>	N-1788	0323-CP	-	-	-	-	-	-

Y

Street

Racing

Racing  
Extreme

CUSTOM

APLICAÇÃO

Ano



APLICAÇÃO	Ano		Street		Racing		Racing Extreme		CUSTOM	
<b>YAMAHA</b>										
YC Z 110	19>	-	N-1788	-	-	-	-	-	-	-
YFM 350 XT/XU WARRIOR	87>88	-	N-919	-	-	-	-	-	-	-
YFM 700 R RAPTOR (LE)	06>	06>	-	-	N-1828	-	N-1828C	-	-	-
YZF 350 T-W BANSHEE	87>89	-	N-919	-	-	-	-	-	-	-
YW 100 T Booster BWs	96>	-	N-1817	-	-	-	-	-	-	-
YZ 125	90>97	93>97	-	-	N-1828	N-1075	N-1828C	N-1075C	-	-
YZ 125	98>02	98>02	-	-	N-991	N-1075	N-991C	N-1075C	-	-
YZ 125	03>07	03>07	-	-	N-991	N-1011	N-991C	N-1011C	-	-
YZ 125	08>	08>	-	-	N-1838	N-1011	N-1838C	N-1011C	-	-
YZ 125 all models	-	90>97	-	N-946	-	-	-	-	-	-
YZ 250	98>02	98>02	-	-	N-991	N-1075	N-991C	N-1075C	-	-
YZ 250	03>07	03>07	-	-	N-991	N-1011	N-991C	N-1011C	-	-
YZ 250	08>	08>	-	-	N-1838	N-1011	N-1838C	N-1011C	-	-
YZ 250 B1/J1	91>97	91>97	-	-	N-1828	N-1828C	-	-	-	-
YZ 250 F	01>02	01>02	-	-	N-991	N-1075	N-991C	N-1075C	-	-
YZ 250 F	03>06	03>06	-	-	N-991	N-1011	N-991C	N-1011C	-	-
YZ 250 F	07>13	07>13	-	-	-	-	N-1838C	N-1011C	-	-
YZ 250 F	07>09	07>09	-	-	-	-	N-1838C	N-1011C	-	-
YZ 250 F Efi	14>	14>	-	-	N-1838	N-1011	N-1838C	N-1011C	-	-
YZ 250 FX Efi	15>	15>	-	-	N-1838	N-1011	N-1838C	N-1011C	-	-
YZ 250 N/S/T	-	85>87	-	0301-CP	-	-	-	-	-	-
YZ 250 U	-	88	-	N-919	-	-	-	-	-	-
YZ 250 V/W/WRW	89>	89>	-	-	N-1828	-	N-1828C	-	-	-
YZ 250 WRA/WRB	90>91	90>91	-	-	N-1828	-	N-1828C	-	-	-
YZ 400 F	98>99	98>99	-	-	N-991	N-1075	N-991C	N-1075C	-	-
YZ 426 F	00>02	00>02	-	-	N-991	N-1075	N-991C	N-1075C	-	-
YZ 450 F	03>07	03>07	-	-	N-991	N-1011	N-991C	N-1011C	-	-
YZ 450 F	08>09	08>09	-	-	N-1838C	N-1011	-	N-1011C	-	-
YZ 450 F Efi	10>13	10>13	-	-	N-1838	N-1011	N-1838C	N-1011C	-	-
YZ 450 F Efi	14>	14>	-	-	N-1838	N-1011	N-1838C	N-1011C	-	-
YZ15R Sniper150	15>	-	N-1880	-	-	-	-	-	-	-
YZ250F	16>18	-	N-1880	-	-	-	-	-	-	-
YZF 1000 R THUNDER ACE	96>	96>	-	-	N-925	N-980	N-925C	N-980C	-	-
YZF 1000 R1	98>01	98>01	-	-	N-925	N-972	N-925C	N-972C	-	-
YZF 1000 R1	02>03	02>03	-	-	N-925	-	N-925C	-	-	-
YZF 1000 R1	04>06	04>06	-	-	N-925	N-927	N-925C	N-927C	-	-
YZF 1000 R1	07>	07>	-	-	N-978	N-927	N-978C	N-927C	-	-
YZF 1000 R1	07>14	07>14	-	-	N-978	N-927	N-978C	N-927C	-	-
YZF 1000 R1	15>	15>	-	-	N-925	N-962	N-925C	N-962C	-	-
YZF 1000 R1 60th Anniversary	16>	16>	-	-	-	N-962	-	N-962C	-	-
YZF 1000 R1 C/ABS	12>	12>	-	-	N-978	N-927	N-978C	N-927C	-	-
YZF 1000 R1 C/ABS	12>14	12>14	-	-	N-978	N-927	N-978C	N-927C	-	-
YZF 1000 R1 M	15>	15>	-	-	N-925	N-962	N-925C	N-962C	-	-
YZF 600 R THUNDER CAT	96>03	96>03	-	-	N-925	N-980	N-925C	N-980C	-	-
YZF 600 R6	99>02	99>02	-	-	N-925	-	N-925C	-	-	-
YZF 600 R6	03>	03>	-	-	N-925	N-927	N-925C	N-927C	-	-
YZF 750 R / SP	93>97	93>97	-	-	-	N-980	-	N-980C	-	-
YZF 750 R7	99>	99>	-	-	N-925	-	N-925C	-	-	-
YZF 750 R7 OW 02	99>	99>	-	-	N-925	N-972	N-925C	N-972C	-	-
YZF R 15	11>16	-	N-951	-	-	-	-	-	-	-
YZF R1	-	02>03	-	N-954	-	-	-	-	-	-
YZF R3	16>	16>	-	-	-	N-1878	-	-	-	-
YZF R3 321	16>	16>	-	-	N-1876	-	-	-	-	-
YZF-R 125	-	08>	-	N-1820	-	-	-	-	-	-
YZF-R25 (RG10)	15>	15>	-	-	N-1876	-	-	-	-	-
YZF-R25 (RG10) 250cc	15>	15>	-	-	-	N-1878	-	-	-	-
<b>ZANELLA</b>										
ZB 110D	05>	-	N-941	-	-	-	-	-	-	-

# CUBO, ESPELHO E FLANGE

MONTADORA	APLICAÇÃO	DIANTEIRA		TRASEIRA		MODELO
		COBREQ REF.	ANO	COBREQ REF.	ANO	
HONDA	BIZ C-100	0007-CB	02>07	0004-CB	TODAS	CUBOS
HONDA	BIZ C-125	0007-CB	02>07	0004-CB	TODAS	CUBOS
HONDA	BIZ C -125 / 125	0022-CB	08>	-	-	CUBOS
HONDA	CG 125	0005-CB	83-89	-	-	CUBOS
HONDA	CG 125	-	-	0001-CB	-99	CUBOS
HONDA	CG FAN 125	0015-CB	08-	0014-CB	08-	CUBOS
HONDA	CG TODAY	-	-	0005-CB	83-89	CUBOS
HONDA	CG TODAY	-	-	0001-CB	-99	CUBOS
HONDA	CG TITAN	-	-	0005-CB	83-89	CUBOS
HONDA	CG TITAN	-	-	0001-CB	-99	CUBOS
HONDA	CG TITAN	0006-CB	00-	0002-CB	00-	CUBOS
HONDA	CG TITAN (DISCO)	0010-CB	00-	-	-	CUBOS
HONDA	CG TITAN 150	0015-CB	08-	0003-CB	04-	CUBOS
HONDA	CG TITAN 150	0011-CB	04-	-	-	CUBOS
HONDA	NXR BROS 125	-	-	0016-CB	03-	CUBOS
HONDA	NXR BROS 150	-	-	0016-CB	03-	CUBOS
HONDA	POP 100	0017-CB	TODAS	0018-CB	TODAS	CUBOS
HONDA	XL 125	0009-CB	TODAS	0008-CB	TODAS	CUBOS
HONDA	Titan ES 125 / 150	0019-CB	TODAS	-	-	CUBOS
HONDA	Titan 150 ES / ESD - BROS 150	0020-CB	TODAS	-	-	CUBOS
YAMAHA	RD 125	0013-CB	87>	0012-CB	87>	CUBOS
YAMAHA	RD 135	0013-CB	87>	0012-CB	87>	CUBOS
YAMAHA	RDZ 125	-	-	0012-CB	87>	CUBOS
YAMAHA	RDZ 125II	-	-	0012-CB	87>	CUBOS
YAMAHA	RX 180	0013-CB	87>	0012-CB	87>	CUBOS
YAMAHA	YBR 125	0013-CB	00>	0012-CB	00>	CUBOS
YAMAHA	YBR 125 ED	0021-CB	TODAS	-	-	CUBOS
HONDA	BIZ C-100	0018-EP	TODAS	0004-EP	TODAS	ESPELHO
HONDA	BIZ C-125	0019-EP	TODAS	0004-EP	TODAS	ESPELHO
HONDA	CG 125	-	-	0001-EP	>99	ESPELHO
HONDA	CG TODAY	-	-	0001-EP	>99	ESPELHO
HONDA	CG TITAN	-	-	0001-EP	>99	ESPELHO
HONDA	CG TITAN	-	-	0002-EP	00>	ESPELHO
HONDA	CG TITAN 150	-	-	0003-EP	04>	ESPELHO
HONDA	Pop 100	-	TODAS	0007 - EP	TODAS	ESPELHO
HONDA	BROS 125 / 150	0015-EP	TODAS	0008 - EP	TODAS	ESPELHO
HONDA	NX - XR200 - XLS	-	TODAS	0009 - EP	TODAS	ESPELHO
HONDA	Tornado 250	-	TODAS	0011 - EP	TODAS	ESPELHO
HONDA	Titan / Cargo 1999	0014 - EP	TODAS	-	-	ESPELHO
HONDA	Titan 150 Sport	-	-	0006-EP	TODAS	ESPELHO
HONDA	Titan 2000 / Fan	0016 - EP	TODAS	-	-	ESPELHO
HONDA	Titan 150	0017 - EP	TODAS	-	-	ESPELHO
HONDA	TWISTER / STRADA	-	-	0010-EP	TODAS	ESPELHO
HONDA	-	-	-	-	-	ESPELHO
HONDA	XLS 125	0021 - EP	TODAS	-	-	ESPELHO
YAMAHA	RD 125	-	-	0005-EP	87>	ESPELHO
YAMAHA	RD 135	-	-	0005-EP	87>	ESPELHO
YAMAHA	RX 180	-	-	0005-EP	87>	ESPELHO
YAMAHA	YBR 125	-	-	0005-EP	00>	ESPELHO
YAMAHA	Fazer 250	-	TODAS	0012 - EP	TODAS	ESPELHO
YAMAHA	YBR 125 E/K	0020 - EP	TODAS	-	-	ESPELHO
YAMAHA	XTZ 125	-	-	0013-EP	TODAS	ESPELHO
HONDA	CG TITAN 150	-	-	0001-FL	04>	FLANGE
HONDA	Bros 125	005-FL	-	0003-FL	-	FLANGE
HONDA	Titan 1999	-	-	0003-FL	-	FLANGE
HONDA	Titan /Cargo	005-FL	-	0003-FL	-	FLANGE
HONDA	BIZ 100	-	-	0004-FL	TODAS	FLANGE
HONDA	BIZ 125	-	-	0006-FL	TODAS	FLANGE
YAMAHA	RD 125	-	-	0002-FL	87>	FLANGE
YAMAHA	RD 135	-	-	0002-FL	87>	FLANGE
YAMAHA	RX 180	-	-	0002-FL	87>	FLANGE
YAMAHA	YBR 125	-	-	0002-FL	00>	FLANGE

## DISCOS DE FREIO

MONTADORA	APLICAÇÃO	DIANTEIRA		TRASEIRA	
		ANO	COBREQ REF.	ANO	COBREQ REF.
DAFRA	NEXT 250	-	-	Todas	0019-DIS
HONDA	BIZ 125	Todas	0022-DIS	-	-
HONDA	BROS 150	Todas	0011-DIS	-	-
HONDA	CB 300	Todas	0004-DIS	Todas	0014-DIS
HONDA	CBX 200 STRADA	Todas	0021-DIS	-	-
HONDA	CRF 230	Todas	0007-DIS	-	-
HONDA	FALCON	Todas	0016-DIS	Todas	0002-DIS
HONDA	TITAN ES	00>04	0010-DIS	-	-
HONDA	TITAN ESD	00>04	0010-DIS	-	-
HONDA	TITAN150 ESD	04>08	0001-DIS	-	-
HONDA	TITAN150 ESD	09>14	0008-DIS	-	-
HONDA	TITAN160	Todas	0008-DIS	-	-
HONDA	TORNADO	Todas	0007-DIS	-	-
HONDA	TWISTER	>08	0004-DIS	-	-
HONDA	XLX 350	Todas	0007-DIS	-	-
HONDA	XR 200	Todas	0007-DIS	-	-
HONDA	XRE 300	-	0015-DIS	Todas	0003-DIS
SUZUKI	BURGMAN CARB	-	0023-DIS	-	-
SUZUKI	BURGMAN INJ	-	0024-DIS	-	-
SUZUKI	YES 125	-	0017-DIS	-	-
YAMAHA	FACTOR 125	Todas	0018-DIS	-	-
YAMAHA	FAZER 250	Todas	0009-DIS	Todas	0006-DIS
YAMAHA	LANDER 250	Todas	0013-DIS	Todas	0005-DIS
YAMAHA	TÉNÉRÉ	-	-	Todas	0005-DIS
YAMAHA	XTZ 125	Todas	0012-DIS	-	-
YAMAHA	YBR 125	00>08	0020-DIS	-	-

## DISCOS DE EMBREAGEM

MONTADORA	APLICAÇÃO	COBREQ REF.	ANO	MONTADORA	APLICAÇÃO	COBREQ REF.	ANO
DAFRA	SPEED 150	0021-DE	08>15	HONDA	XLX 350R	0015-DE	-
HONDA	CG 125	0001-DE	-	HONDA	CB 500	0017-DE	-
HONDA	CG 125 FAN	0021-DE	05>13	JONNY	HYPE 50	0008-DE	-
HONDA	CG 125 TITAN	0021-DE	94>04	KASINSKI	SOFT 50	0016-DE	-
HONDA	CG TITAN 150	0001-DE	-	SHINERAY	XY 50Q	0003-DE	-
HONDA	CG 150 FAN	0021-DE	09>15	SHINERAY	PHOENIX	0009-DE	-
HONDA	CG 150 TITAN	0021-DE	04>08	SUZUKI	INTRUDER 125	0019-DE	-
HONDA	CG 160 TITAN/FAN/ START/CARGO	0021-DE	2016>	SUZUKI	YES 125	0019-DE	-
HONDA	NXR 125	0001-DE	-	TRAXX	STAR 50	0010-DE	-
HONDA	NXR 125 BROSS	0021-DE	03>05	YAMAHA	YBR 125	0002-DE	-
HONDA	NXR 150 BROS	0021-DE	06>15	YAMAHA	XTZ 125	0002-DE	-
HONDA	NXR 160 BROS	0021-DE	2016>	YAMAHA	FAZER 250	0012-DE	-
HONDA	BIZ 125	0004-DE	-	YAMAHA	XTZ 250 LANDER	0012-DE	-
HONDA	CBX 250	0005-DE	-	YAMAHA	CRYPTON 105	0013-DE	98>05
HONDA	XR 250	0005-DE	-	YAMAHA	XT 225	0014-DE	-
HONDA	C 100 DREAM	0006-DE	-	YAMAHA	DT 200	0018-DE	-
HONDA	C 100 BIZ	0006-DE	-	YAMAHA	YZ80	0018-DE	95>01
HONDA	CBX 200	0007-DE	-	YAMAHA	FACTOR 150 ED/ESD	0020-DE	-
HONDA	NXR 125	0001-DE	-	YAMAHA	FAZER 150	0020-DE	14>
HONDA	NXR 150	0007-DE	-	YAMAHA	XTZ CROSSER 150 ED	0020-DE	14>
HONDA	CB 300R	0011-DE	-	YAMAHA	YBR 125 FACTOR	0020-DE	17>
HONDA	NX4 FALCON 400	0011-DE	99>				
HONDA	XLX 250R	0015-DE	-				



CABOS DE COMANDO

MONTADORA	APLICAÇÃO	COBREQ.REF.	ANO	OBS	MONTADORA	APLICAÇÃO	COBREQ.REF.	ANO	OBS
<b>CABOS DE ACELERADOR</b>					<b>CABOS DE AFOGADOR</b>				
DAFRA	SUPER 100	0024-CABOA	-	-	DAFRA	KANSAS 150	002-CABOAF	-	-
DAFRA	KANSAS 150	0025-CABOA	-	-	HONDA	BIZ 125	003-CABOAF	-	-
DAFRA	LASER 150	0026-CABOA	-	-	HONDA	NX4 FALCON	005-CABOAF	-	-
HONDA	CG 125	0001-CABOA	83>87	-	HONDA	C100 DREAM	006-CABOAF	-	-
HONDA	ML 125	0001-CABOA	83>84	-	HONDA	TWISTER	007-CABOAF	-	-
HONDA	CG TODAY 125	0002-CABOA	91>94	-	HONDA	CBX 150 AERO	008-CABOAF	-	-
HONDA	CG CARGO	0002-CABOA	-	-	HONDA	NX 150	009-CABOAF	-	-
HONDA	CG 125	0002-CABOA	>99	-	HONDA	NX 200	010-CABOAF	-	-
HONDA	CBX 200 STRADA	0003-CABOA	00>	B	HONDA	XR 200R	010-CABOAF	-	-
HONDA	CG TITAN 125 KS/ES	0004-CABOA	00>	-	HONDA	CBX 200 STRADA	011-CABOAF	-	-
HONDA	CG TITAN ES/KS/KSE/CA	0005-CABOA	02>	-	SUNDOWN	WEB 100	001-CABOAF	-	-
HONDA	CG 125	0006-CABOA	-	-	YAMAHA	TT-R125	004-CABOAF	08>10	-
HONDA	ML 125	0006-CABOA	>81	-	<b>CABOS DE EMBREAGEM</b>				
HONDA	CBX 200 STRADA	0007-CABOA	-	A	DAFRA	SUPER 100	0022-CABOE	-	-
HONDA	XR 200R	0008-CABOA	-	A	DAFRA	KANSAS 150	0023-CABOE	-	-
HONDA	XLR 125	0009-CABOA	-	-	HONDA	CG 125	0001-CABOE	83>87	-
HONDA	C 100 BIZ	0010-CABOA	-	-	HONDA	ML	0001-CABOE	83	-
HONDA	TWISTER	0011-CABOA	-	A	HONDA	XL 125-S	0002-CABOE	-	-
HONDA	TWISTER	0012-CABOA	-	B	HONDA	CG TODAY	0003-CABOE	-	-
HONDA	NXR 125 BROS	0013-CABOA	2003	-	HONDA	CARGO E/D	0003-CABOE	91	-
HONDA	TITAN 150 ES/KS/ESD/J	0014-CABOA	-	-	HONDA	CBX 200 STRADA	0004-CABOE	-	-
HONDA	XL 125-S	0015-CABOA	-	-	HONDA	XR 200R	0005-CABOE	-	-
HONDA	XR TORNADO	0016-CABOA	00>08	A	HONDA	CG 125 TITAN	0006-CABOE	>99	-
HONDA	XR 200R	0030-CABOA	-	B	HONDA	XLR 125	0007-CABOE	-	-
HONDA	BIZ 125	0031-CABOA	05>08	-	HONDA	TITAN KS/ES	0008-CABOE	2000	-
HONDA	BIZ 125 I.E.	0032-CABOA	09>	-	HONDA	TITAN KS/ES/KSE/CARGO	0009-CABOE	-	-
HONDA	POP 100	0033-CABOA	>13	-	HONDA	NXR 125 KS BROS	0010-CABOE	2003	-
HONDA	CG TITAN MIX	0034-CABOA	>09	-	HONDA	TITAN 150 ES/KS/ESD	0011-CABOE	-	-
HONDA	CG 125 FAN ES/KS/CARGO	0035-CABOA	-	-	HONDA	CG 125	0012-CABOE	-	-
HONDA	NXR 150 BROS	0036-CABOA	2009	-	HONDA	ML	0012-CABOE	>82	-
HONDA	CG 150 SPORT	0037-CABOA	-	-	HONDA	TORNADO	0013-CABOE	-	-
HONDA	NX 350 SAHARA	0038-CABOA	-	B	HONDA	TWISTER	0014-CABOE	-	-
HONDA	NX 200	0039-CABOA	-	B	HONDA	NXR 150 KS BROS	0015-CABOE	-	-
HONDA	XRE 300	0040-CABOA	2009	A	HONDA	NXR 150 BROS KS/ES/ESD	0017-CABOE	-	-
HONDA	XRE 300	0041-CABOA	2009	B	HONDA	POP 100	0026-CABOE	2009	-
HONDA	CB 300R	0042-CABOA	2010	A	HONDA	CG 150 TITAN MIX	0027-CABOE	2009	-
HONDA	CB 300R	0043-CABOA	2010	B	HONDA	CG 125 FAN ES/KS/CARGO	0028-CABOE	-	-
HONDA	CB 300R C/ABS	0044-CABOA	2010	A	HONDA	NXR 150 BROS	0029-CABOE	2009	-
HONDA	CB 300R C/ABS	0045-CABOA	2010	B	HONDA	CB300R E.D/CB300R C/ABS	0031-CABOE	2010	-
HONDA	NXR 150 BROS ES/KS/ES	0046-CABOA	-	-	HONDA	CG 150 SPORT	0036-CABOE	-	-
HONDA	C 100 DREAM	0050-CABOA	-	-	HONDA	CG 125 FAN	0037-CABOE	>08	-
HONDA	XR 250 TORNADO	0051-CABOA	-	B	HONDA	CRF 203F	0038-CABOE	03>11	-
HONDA	CG 125 FAN ES/KS/CARGO	0052-CABOA	2009	-	SHINERAY	XY 50Q	0025-CABOE	-	-
HONDA	NX4 FALCON	0053-CABOA	06>	A	SUNDOWN	MAX SE/SED	0020-CABOE	-	-
HONDA	NX4 FALCON	0054-CABOA	06>	B	SUNDOWN	HUNTER 125	0020-CABOE	-	-
HONDA	NX4 FALCON	0063-CABOA	00>05	B	SUNDOWN	HUNTER 90CC	0035-CABOE	-	-
HONDA	NX4 FALCON	0065-CABOA	00>05	A					
HONDA	CRF 230F	0066-CABOA	03>07	B					
HONDA	CRF 230F	0067-CABOA	08>11	B					
HONDA	CRF 230F	0068-CABOA	03>07	A					
HONDA	CRF 230F	0069-CABOA	08>11	A					
HONDA	BIZ 125 KS/ES/EX	0070-CABOA	2011	-					
HONDA	CG 150 FAN E.D.	0071-CABOA	2010	-					
HONDA	CB 300	0072-CABOA	2011	B					
SHINERAY	XY 50Q	0029-CABOA	-	-					
SUNDOWN	WEB 100	0010-CABOA	-	-					
SUNDOWN	HUNTER	0021-CABOA	-	-					
SUNDOWN	MAX SE/SED	0021-CABOA	-	-					
SUNDOWN	NEW WEB	0022-CABOA	-	-					
SUNDOWN	HUNTER 90	0023-CABOA	-	-					
SUNDOWN	STX MOTARD	0048-CABOA	-	A					
SUNDOWN	STX MOTARD	0049-CABOA	-	B					

**CABOS DE COMANDO**

MONTADORA	APLICAÇÃO	COBREQ REF.	ANO	OBS	MONTADORA	APLICAÇÃO	COBREQ REF.	ANO	OBS
SUZUKI	YES 125	0019-CABOE	-		HONDA	C 100 DREAM	0034-CABOV	-	
SUZUKI	INTRUDER 125	0024-CABOE	>05		SHINERAY	XY 50Q	0027-CABOV	-	
SUZUKI	YES 125 E.D.	0032-CABOE	2008		SUZUKI	YES 125	0025-CABOV	-	
YAMAHA	YBR ED/E-K	0016-CABOE	00>08		SUZUKI	KATANA 125	0025-CABOV	-	
YAMAHA	XTZ 125	0018-CABOE	2003		SUZUKI	INTRUDER 125	0023-CABOV	-	
YAMAHA	YBR 125 FACTOR ED/E/K	0030-CABOE	-		SUZUKI	INTRUDER 125	0024-CABOV	-	
YAMAHA	TT-R125	0033-CABOE	08>10		SUZUKI	YES 125	0017-CABOV	-	
YAMAHA	XTZ 125	0034-CABOE	2009		SUZUKI	KATANA 125	0017-CABOV	-	
YAMAHA	XTZ 125 X E/K0	0034-CABOE	2009		SUZUKI	BURGMAN 125	0026-CABOV	-	
<b>CABOS DE FREIO</b>					SUNDOWN	WEB 100	0018-CABOV	-	
DAFRA	LASER 150	0016-CABOF	-	-	SUNDOWN	HUNTER	0019-CABOV	-	
HONDA	TITAN KS	0001-CABOF	2000	-	SUNDOWN	MAX SED	0020-CABOV	-	
HONDA	TITAN FAN	0002-CABOF	02>08	DIANTEIRO	SUNDOWN	NEW WEB	0021-CABOV	-	
HONDA	CG 125	0003-CABOF	83>88	-	YAMAHA	YBR 125 KS	0013-CABOV	00>02	
HONDA	CG TITAN 125/CARGO	0003-CABOF	>97	-	YAMAHA	ZTX 125	0016-CABOV	2003	
HONDA	CG TITAN 125/CARGO	0005-CABOF	98>99	-	YAMAHA	YBR 125 FACTOR EK	0013-CABOV	-	
HONDA	C 100 BIZ	0006-CABOF	-	-	YAMAHA	YBR 125	0036-CABOV	-	
HONDA	NXR 125 KS BROS	0007-CABOF	-	DIANTEIRO	YAMAHA	NEO	0037-CABOV	2010	
HONDA	TITAN 150 ES/KS/JOB	0008-CABOF	>2008	-					
HONDA	XL 125	0009-CABOF	>91	-					
HONDA	BIZ 125 KS/ES/EX	0010-CABOF	05>12	DIANTEIRO					
HONDA	BIZ 125 I.E.	0019-CABOF	-	DIANTEIRO					
HONDA	POP 100	0020-CABOF	2009	-					
HONDA	CG 150 TITAN MIX	0021-CABOF	-	DIANTEIRO					
HONDA	CG 125 FAN ES/KS/CARGO	0022-CABOF	2009	-					
HONDA	C 100 DREAM	0024-CABOF	-	DIANTEIRO					
HONDA	CG 125 FAN	0025-CABOF	2007	DIANTEIRO					
SHINERAY	XY 50Q	0018-CABOF	-	DIANTEIRO					
SUNDOWN	WEB 100	0012-CABOF	-	DIANTEIRO					
SUNDOWN	HUNTER	0013-CABOF	-	-					
SUNDOWN	NEW WEB	0014-CABOF	-	-					
SUNDOWN	HUNTER 90	0015-CABOF	-	DIANTEIRO					
SUZUKI	NA 125 BURGMAN	0017-CABOF	-	TRASEIRO					
YAMAHA	YBR 125	0011-CABOF	00>08	-					
YAMAHA	YBR 125 FACTOR ED/EK	0023-CABOF	2009	-					
<b>CABOS DE VELOCIMETRO</b>									
DAFRA	SPEED 150	0022-CABOV	-						
HONDA	CG 125	0001-CABOV	83>84						
HONDA	CG 125 TITAN	0002-CABOV	>99						
HONDA	NX 150	0003-CABOV	-						
HONDA	XR 200	0003-CABOV	-						
HONDA	CBX 200 STRADA	0004-CABOV	-						
HONDA	NX 200	0005-CABOV	-						
HONDA	XLR 125	0005-CABOV	-						
HONDA	NX4 FALCON	0005-CABOV	-						
HONDA	C 100 BIZ	0006-CABOV	-						
HONDA	TITAN	0005-CABOV	00>08						
HONDA	NXR 125	0005-CABOV	2013						
HONDA	TWISTER	0008-CABOV	-						
HONDA	CG TITAN ES	0009-CABOV	00>02						
HONDA	TORNADO	0005-CABOV	-						
HONDA	TITAN 150 ES/KS/ESD	0011-CABOV	-						
HONDA	BIZ 125	0012-CABOV	05>08 /2012						
HONDA	XLS 125 DUTY	0014-CABOV	-						
HONDA	NXR 150 KS BROS	0015-CABOV	-						
HONDA	BIZ 125	0028-CABOV	2009						
HONDA	POP 100	0029-CABOV	2009						
HONDA	CG 150 TITAN MIX	0030-CABOV	-						
HONDA	CG 125 FAN ES/KS/CARGO	0011-CABOV	-						
HONDA	LEAD 110	0032-CABOV	2009						
HONDA	NXR 150 BROS	0033-CABOV	2009						

REFERÊNCIAS CRUZADAS | PASTILHAS

COBREQ	ORIGINAL	EBC	DIAFRAG	FISCHER
N-901	11HW004500	FA 081	DFP-10810	FJ 810
N-902	45105413003	FA 045	DFP-10808	FJ 720
N-905	43105KK9691	FA 122	DFP-10808	FJ 790
N-906	06455-GBZ-006	FA 054	DFP-40800	FJ 780
N-907	45105 461 771	FA 29 / FA 30	DFP-10822	FJ 740
N-909	06455KCW425	FA 092	DFP-40807	FJ 840
N-910	1KTW004652	FA 104	DFP-10809	FJ 830
N-911	06435 MT8 405	FA 069	-	FJ 820
N-912	06455 443 405	FA 069-2	-	FJ 825
N-913	55W W0045 00	FA 118	-	FJ 850
N-914	8113104	FA 060	DFP-10812	FJ 770
N-915	06455K40F11	-	DFP-40820	FJ 870
N-917	06455 GZ8 405	FA 185	DFP-40801	FJ 860
N-919	1UYW004500	FA 101	DFP-40805	FJ 900
N-922	430821199	FA 188	-	FJ 1050
N-922C	430821199	FA 188	-	FJ 1050
N-923	06455MAS305	FA 187	-	FJ 1420
N-923C	06455MAS305	FA 187	-	FJ 1420
N-924	5910016820	FA 063	DFP-40824	FJ 920
N-924C	5910016820	FA 063	DFP-40824	FJ 920
N-925	3JD W0046 00	FA 252	-	FJ 1780
N-925C	3JD W0046 00	FA 252	-	FJ 1780
N-926	06455 MAS E01	FA 265	-	FJ 1660
N-926C	06455 MAS E01	FA 265	-	FJ 1660
N-927	06435 MEJ 016	FA 174	DFP-20834/40849	FJ 1150
N-927C	06435 MEJ 016	FA 174	DFP-20834/40849	FJ 1150
N-929	43082 1097	FA 158	-	FJ 1100
N-929C	43082 1097	FA 158	-	FJ 1100
N-930	06435-MT3-405	FA196	DFP-40821/40842	FJ 875
N-930C	06435-MT3-405	FA196	DFP-40821/40842	FJ 875
N-932	06435-MAK-003	FA 213	DFP-40813	FJ 1070
N-932C	06435-MAK-003	FA 213	DFP-40813	FJ 1070
N-934	06455 MAK 000	FA 209/2	DFP-40814	FJ 1480
N-934C	06455 MAK 000	FA 209/2	DFP-40814	FJ 1480
N-940	06455-KW6-844	FA 165	DFP-20802/40802	FJ 1850
N-941	-	-	DFP-20846/40846	FJ 945
N-942	43082 0082	FA 135	DFP-20803/40803	FJ 940
N-943	06435 KCZ 000	FA 131	DFP-20804/40804	FJ 1030
N-946	3C5-25806-00	FA 152	DFP-40839	FJ 2190
N-947	43050 1040	FA 083TT	DFP-20818/40818	FJ 1290
N-949	0000 640 7210	-	DFP-20841/40841	FJ 2090
N-951	2DP-F582W-00	FA 464	DFP-20840/40840	FJ 2320
N-954	4730480	FA 275	-	FJ 1730
N-956	2020073 T0301	FA 236	-	FJ 922
N-956C	2020073 T0301	FA 236	-	FJ 922
N-957	06455 MAS 305	FA 187	-	FJ 927
N-957C	06455 MAS 305	FA 187	-	FJ 927
N-958	43082 1178	FA 231	DFP-40828	FJ 1440
N-958C	43082 1178	FA 231	DFP-40828	FJ 1440
N-959	43082 1177	FA 229	DFP-40829	FJ 1450
N-959C	43082 1177	FA 229	DFP-40829	FJ 1450
N-962	06435 MEL D21	FA 436	DFP-40843	FJ 2260
N-962C	06435 MEL D21	FA 436	DFP-40843	FJ 2260
N-964	06455-KYJ-912	FA388	DFP-40886	FJ 2360
N-964C	06455-KYJ-912	FA388	DFP-40886	FJ 2360
N-966	59100 19820	FA 146	-	FJ 1170
N-966C	59100 19820	FA 146	-	FJ 1170
N-967	-	FA369	-	FJ 2070
N-967C	-	FA369	-	FJ 2070
N-968	06455 MZ2 405	FA 189	-	FJ 1240
N-968C	06455 MZ2 405	FA 189	-	FJ 1240
N-970	1B7 W0045 00	FA 199	-	FJ 1430
N-970C	1B7 W0045 00	FA 199	-	FJ 1430
N-971	3YX W0045 00	FA 179	-	FJ 1090
N-971C	3YX W0045 00	FA 179	-	FJ 1090
N-972	4XV W0046 00	FA 267	-	FJ 1810
N-972C	4XV W0046 00	FA 267	-	FJ 1810

## REFERÊNCIAS CRUZADAS | PASTILHAS

COBREQ	ORIGINAL	EBC	DIAFRAG	FISCHER
N-973	06435 MAJ G41	FA 261HH	-	FJ 1610
N-973C	06435 MAJ G41	FA 261HH	-	FJ 1610
N-975	-	FA103	-	FJ 1340
N-975C	-	FA103	-	FJ 1340
N-976	59300 14870	SFA 283	-	FJ 1890
N-976C	59300 14870	SFA 283	-	FJ 1890
N-977	43082 1182	FA 254	-	FJ 1790
N-977C	43082 1182	FA 254	-	FJ 1790
N-978	4C8 W0045 00	FA 442/4	-	FJ 2370
N-978C	4C8 W0045 00	FA 442/4	-	FJ 2370
N-980	1FK W0045 00	FA 088	-	FJ 1010
N-980C	1FK W0045 00	FA 088	-	FJ 1010
N-981	43082 0111	FA 192	-	FJ 1330
N-981C	43082 0111	FA 192	-	FJ 1330
N-983	43082 0091	FA 379HH	-	FJ 2150
N-983C	43082 0091	FA 379HH	-	FJ 2150
N-984	69101 44810	FA 419	-	FJ 2350
N-984C	69101 44810	FA 419	-	FJ 2350
N-986	3GM W0045 00	FA 160	-	FJ 1002
N-986C	3GM W0045 00	FA 160	-	FJ 1002
N-987	1NL W0045 00	FA 123	-	FJ 1590
N-987C	1NL W0045 00	FA 123	-	FJ 1590
N-988	06455 MEL 003	FA 390	-	FJ 2250
N-988C	06455 MEL 003	FA 390	-	FJ 2250
N-989	06435 MAJ G41	FA 261HH	-	FJ 1620
N-989C	06435 MAJ G41	FA 261HH	-	FJ 1620
N-991	06455 GZ8 405	FA 185	DFP-40837	FJ 865
N-991C	06455 GZ8 405	FA 185	DFP-40837	FJ 865
N-993	2GS-W0045-00	FA 181	-	-
N-993C	2GS-W0045-00	FA 181	-	-
N-995	06435 KZ4 J41	FA 346	DFP-40835	FJ 1880
N-995C	06435 KZ4 J41	FA 346	DFP-40835	FJ 1880
N-997	548 13 090 000	FA 368	-	FJ 2000
N-997C	548 13 090 000	FA 368	-	FJ 2000
N-1011	5UN W0046 00	FA 367	DFP-40827	FJ 1910
N-1011C	5UN W0046 00	FA 367	DFP-40827	FJ 1910
N-1013	-	-	-	FJ 1520
N-1073	800079072	FA 208	-	FJ 1070
N-1073C	800079072	FA 208	-	FJ 1070
N-1075	06435 KCZ 000	FA 131	DFP-40804	FJ 1030
N-1075C	06435 KCZ 000	FA 131	DFP-40804	FJ 1030
N-1600	44082 00C	FA 400	-	FJ 1820
N-1602	44005 74	FA 024/2	-	FJ 990
N-1603	4306383	FA 094	-	FJ 1630
N-1605	44209 87B	FA 200	-	FJ 1670
N-1606	43957 86	FA 201	-	FJ 1400
N-1607	42831-04A	FA381	-	FJ 2230
N-1609	44082-08	FA 457HH	-	FJ 2720
N-1611	41852-08	FA 409HH	-	FJ 2430
N-1613	42298-08	FA 458	-	FJ 2340
N-1615	42836-04	FA387	-	FJ 2240
N-1617	06435 KYJ 901	FA 140	DFP-20857/40857	-
N-1619	06455 MBT D51	FA 388	-	FJ 2360
N-1621	43082 1182	FA 254	-	FJ 1790
N-1788	06455 KWB 601	-	-	FJ 2680
N-1790	-	FA630	-	-
N-1790C	-	FA630	-	-
N-1791	4PT-W0045-00	FA 172	-	FJ 1120
N-1791C	4PT-W0045-00	FA 172	-	FJ 1120
N-1800	-	-	-	FJ 1460
N-1802	-	-	-	-
N-1804	06455 MY9 871	FA 244	-	FJ 1760
N-1804C	06455 MY9 871	FA 244	-	FJ 1760
N-1805	3D8-25806-00	FA 319/2	-	FJ 2450
N-1805C	5JW W0046 00	FA 319/2	-	FJ 2450
N-1806	34 21 2 314 947	FA 363	-	-
N-1806C	34 21 2 314 947	FA 363	-	-

REFERÊNCIAS CRUZADAS | PASTILHAS

COBREQ	ORIGINAL	EBC	DIAFRAG	FISCHER
N-1808	-	FA 294HH	-	-
N-1808C	-	FA 294HH	-	-
N-1809	34 11 7 660 448	FA 335HH	-	-
N-1809C	34 11 7 660 448	FA 335HH	-	-
N-1810	34 11 7 714 800	FA 604/4HH	-	-
N-1810C	34 11 7 714 800	FA 604/4HH	-	-
N-1811	61013030100	FA 322/4HH	-	-
N-1811C	613 403 01A	FA 322/4HH	-	-
N-1812	43082 1290	FA 347	-	-
N-1812C	43082 1290	FA 347	-	-
N-1813	-	FA447	-	-
N-1813C	-	FA447	-	-
N-1815	06435 MFN D01	FA 488HH	-	FJ 2560
N-1815C	06435 MFN D01	FA 488HH	-	FJ 2560
N-1817	2NA W0045 01	SFA 169	-	FJ 1140
N-1818	613 4 021 1A	FA 266	-	FJ 1770
N-1818C	613 4 021 1A	FA 266	-	FJ 1770
N-1819	G7131 LRAO 000	FA 427	-	FJ 2510
N-1820	45105 LB17 3050	FA 377	-	FJ 2520
N-1822	-	-	-	FJ 2420
N-1822C	-	-	-	FJ 2420
N-1824	06435 KYJ 901	FA 140	-	FJ 1160
N-1824C	06435 KYJ 901	FA 140	-	FJ 1160
N-1826	43020 CEK 000	FA 165	DFP-40802	FJ 1850
N-1826C	43020 CEK 000	FA 165	DFP-40802	FJ 1850
N-1828	43082 0082	FA 135	DFP-40803	FJ 940
N-1828C	43082 0082	FA 135	DFP-40803	FJ 940
N-1830	8000 82748	FA 320HH	-	-
N-1830C	8000 82748	FA 320HH	-	-
N-1831	06435 HA5 405	FA 084/3	-	-
N-1831C	06435 HA5 405	FA 084/3	-	-
N-1832	43082 1196	FA 258	-	FJ 2010
N-1832C	43082 1196	FA 258	-	FJ 2010
N-1834	06455-K43-911	-	DFP-20850	FJ 2660
N-1836	06455 K21 921	-	-	FJ 2650
N-1838	5XC W0045 00	FA 450	-	FJ2380M
N-1838C	5XC W0045 00	FA 450	-	FJ2380M
N-1840	06435-KRE-G31	FA629	-	FJ 2670
N-1876	1WD-25805-00	FA663HH	-	FJ2790
N-1878	1WD-25806-00	FA662HH	-	-
N-1880	2BM-F5805-00	FA694	-	FJ2780
N-1882	064455-k67-951	-	DFP-20906	FJ2840
N-1886	-	-	-	-
N-1889	59300Z2DY00A00	-	-	FJ2900
N-1891	06435-K40-F02	-	-	FJ 2880
N-1892C	34 11 8 405 104	FA 724HH	-	-

REFERÊNCIAS CRUZADAS | DISCO DE FREIO

COBREQ	ORIGINAL	COBREQ	ORIGINAL	COBREQ	ORIGINAL	COBREQ	ORIGINAL
0001-DIS	-	0008-DIS	45251-KVS-901	0015-DIS	45351KWT900	0022-DIS	45351KSS950
0002-DIS	43251MCG000	0009-DIS	1S4F582U00	0016-DIS	45351KAS970	0023-DIS	-
0003-DIS	43251KWT900	0010-DIS	45251-KGA-940	0017-DIS	-	0024-DIS	-
0004-DIS	45251-KPF-900	0011-DIS	-	0018-DIS	-		
0005-DIS	53PF582W00	0012-DIS	-	0019-DIS	-		
0006-DIS	44C-F582W-00	0013-DIS	4B4F582T01	0020-DIS	5HH- F582U-00		
0007-DIS	45351-KPS-900	0014-DIS	43251-KVK-770	0021-DIS	-		

**REF. CRUZADAS | CUBOS**

COBREQ	ORIGINAL	DIAFRAG
0001-CB	42611-397-630	DFH-00500
0002-CB	42601-KGA-900	DFH-00501
0003-CB	42635-KRM-860	DFH-00510
0004-CB	44635-GCE-900	DFH-00502
0005-CB	44601-397-630	DFH-00504
0006-CB	44635-KGA-K00	DFH-00505
0007-CB	42635-GCE-900	DFH-00506
0008-CB	42601-437-000	DFH-00507
0009-CB	44801-437-970	DFH-00511
0010-CB	44601-KGA-940	DFH-00512
0011-CB	44635-KRM-860	DFH-00513
0012-CB	5HHF5-311-0035	DFY-00600
0013-CB	2H3F5-111-A035	DFY-00601
0014-CB	42635-KWG-600	DFH-00514
0015-CB	44635-KRM-B90	DFH-00515
0016-CB	42635-KRE-850	DFH-00517
0017-CB	44635-GFP-900	-
0018-CB	42635-GFO-900	-
0022-CB	-	DFH-00520

**REF. CRUZADAS | ESPELHO**

COBREQ	ORIGINAL	DIAFRAG
0001-EP	43100-KYO-930	DFH-00125
0002-EP	43100-KGA-900	DFH-00503
0003-EP	43100-KRM-860	DFH-00516
0004-EP	43100-GCE-900	DFH-00508
0005-EP	5HHF5-321-0235	DFY-00602

**REF. CRUZADAS | FLANGE**

COBREQ	ORIGINAL	DIAFRAG
0001-FL	42615-KRM-860	DFH-00509
0001-FL	42615-KRM-840	DFH-00509
0002-FL	23LF5-366-00	DFY-00603

**REF. CRUZADAS | PATIM**

COBREQ	ORIGINAL	DIAFRAG	FISCHER
0301-CP	5HH-53300-0	DFY-00211	PV 0901
0302-CP	06430-KGA-900	DFH-00127	PV 0200
0303-CP	-	DFY-00209	PV 1294
0304-CP	06430-KYO-860	DFH-00120	PV 1092
0307-CP	-	DFY-00206	-
0308-CP	-	DFY-00210	-
0309-CP	-	DFH-00124	PV 1194
0311-CP	-	DFC-00401	-
0312-CP	45120-KB7-005	DFH-00122	-
0313-CP	06430-KBB-405	DFH-00121	PV 0294
0314-CP	06450-KAS-890	DFH-00126	-
0318-CP	-	DFA-00303	-
0320-CP	06430-GCE-F20	DFH-00123	PV 1094
0321-CP	54410-45F-00-H000	DFS-00402	PV 1096
0322-CP	54410E00	DFS-00403	PV 0908
0323-CP	18D-WF53A-00	DFY-00215	PV 0609

**REFERÊNCIAS CRUZADAS  
KIT TRANSMISSÃO**

COBREQ	RIFFEL	COFAP	NAKATA
0001-KR	71782	TMC410002	TM10105
0002-KR	71877	TMC413800	TM10100
0003-KR	96094	-	TM10190
0004-KR	71848	TMC413567	TM10130
0005-KR	91176	-	-
0006-KR	91048	TMC410005	TM10115
0007-KR	71879	TMC424510	TM10255
0008-KR	71827	TMC413673	TM10120
0009-KR	96097	-	TM10185
0011-KR	71790	TMC411190	TM10125
0012-KR	71788	TMC411104	TM10110
0013-KR	71761	TMC410001	TM10140
0014-KR	71343	-	TM11205
0015-KR	70709	TMC430001	TM10300

**REFERÊNCIAS CRUZADAS  
DISCOS DE EMBREAGEM**

COBREQ	ORIGINAL	COBREQ	ORIGINAL
0001-DE	H2220-KBW-901	0014-DE	36X-16321-00
0002-DE	598-16321-01	0015-DE	22201-377-000
0003-DE	-	0016-DE	-
0004-DE	22201-KPH-900	0017-DE	22201-KAE-000
0005-DE	22201-MAL-600	0018-DE	3XP-16321-00
0006-DE	22201-KPH-900	0019-DE	21441J13A20J000
0007-DE	22201-MJ8-000	0020-DE	1STE632100
0008-DE	-		1STE633100
0009-DE	-		
0010-DE	-		
0011-DE	2201-HM3-A60		
0012-DE	1S4-E6331-00		
0013-DE	4ST-16321-00		

**REFERÊNCIAS CRUZADAS  
KIT DE EMBREAGEM**

COBREQ	ORIGINAL	COBREQ	ORIGINAL
0001-KE	H0620-KGA-900	0009-KE	-
0002-KE	H0620-KRM-900	0010-KE	-
0003-KE	-	0011-KE	-
0004-KE	H0620-K19-900	0012-KE	-
0005-KE	5RMWE63100	0014-KE	19562333
0006-KE	-	0015-KE	-
0007-KE	-	0016-KE	-
0008-KE	06222KSS-900		

REFERÊNCIAS CRUZADAS | CABOS

COBREQ	ORIGINAL	COBREQ	ORIGINAL	COBREQ	ORIGINAL
0001-CABOA	17910.397.6302	0013-CABOE	22870.KPE.9000	0029-CABOV	44830.GFP.900
0001-CABOAF	022GUI0010	0013-CABOF	042ACI0006	0030-CABOA	17920.KBB.9000
0001-CABOE	22870.397.6302	0013-CABOV	18D.H3550.10	0030-CABOE	18D.26335.00
0001-CABOF	45450.KGA.9000	0013-CABOV	5HH.H3550.01	0030-CABOV	44830.KVS.600
0001-CABOV	44830.397.6301	0014-CABOA	17910.KRM.860	0031-CABOA	17910.KSS.9000
0002-CABOA	17910.KY0.9700	0014-CABOE	22870.KPF.900	0031-CABOE	22870.KVK-960
0002-CABOAF	D02531690000SI	0014-CABOF	072GUI0005	0031-CABOE	22870.KVK.900
0002-CABOE	22870.437.971	0014-CABOV	448304379700	0031-CABOV	44830.KWG.600
0002-CABOF	45450.KGA.B00	0015-CABOA	179104379702	0032-CABOA	17910.KSS.B31
0002-CABOV	44830.KCH.9000	0015-CABOE	22870.KRE.9000	0032-CABOE	58200-45F41
0003-CABOA	17920.KBW.9000	0015-CABOF	044ACI0006	0032-CABOV	44830.GFM.970
0003-CABOAF	17950.KSS.900	0015-CABOV	44830.KRE.900	0033-CABOA	17910.GFP.900
0003-CABOE	22870.KY0.9701	0016-CABOA	17910.KPE.9000	0033-CABOE	5HP.26335.00
0003-CABOF	45450.397.6303	0016-CABOE	5HH.F6335.02	0033-CABOV	44830.KRE.850
0003-CABOF	45450.KCH.9000	0016-CABOF	D06531030000SI	0034-CABOA	17910.KVS.600
0003-CABOV	44830.KW8.9000	0016-CABOV	5RM.H3550.00	0034-CABOE	21D.26335.00
0004-CABOA	17910.KGA.9000	0017-CABOA	5HH.F6311.10	0034-CABOV	44830.GN5.9000
0004-CABOAF	-	0017-CABOE	22870.KRE.850	0035-CABOA	17910.KWG.600
0004-CABOE	22870.KBW.9001	0017-CABOE	22870.KRE.B00	0035-CABOE	044ACI0001
0004-CABOF	45450.KCH.9000	0017-CABOF	58510.37G00	0035-CABOV	18D.H3550.10
0004-CABOV	44830.KW1.9005	0017-CABOV	3491026411	0036-CABOA	17910.KRE.B00
0005-CABOA	17910.KGA.B00	0018-CABOA	5HH.F6311.01	0036-CABOE	22870.KRM.870
0005-CABOAF	17950.MCG.0000	0018-CABOE	5RM.F6335.00	0036-CABOV	5HH.H3550.00
0005-CABOE	22870.KBB.9000	0018-CABOF	-	0037-CABOA	17910.KRM.870
0005-CABOF	45450.KCH.9100	0018-CABOV	022INS0006	0037-CABOE	22870.KGA.B400
0005-CABOV	44830.KCC.9000	0019-CABOA	022GUI0008	0037-CABOV	1P7.H3550.00
0005-CABOV	44830.KY7.0000	0019-CABOE	58200.45F00	0038-CABOA	17920.KAS.9000
0005-CABOV	44830.KY7.0002	0019-CABOF	45450.KSS.B30	0038-CABOE	22870.KPS.900
0006-CABOA	17910.397.3050	0019-CABOV	042INS0033	0039-CABOA	17920.KBZ.9000
0006-CABOAF	17950.KAS.9001	0020-CABOA	042ACI0001	0039-CABOE	22870-KVK-960
0006-CABOE	22870.KCH.9000	0020-CABOE	032GUI0002	0040-CABOA	17910.KWT.900
0006-CABOE	22870.KY0.9701	0020-CABOF	042ACI0002	0041-CABOA	17920.KWT.900
0006-CABOF	45450.GCE.9100	0020-CABOV	45450.GFP.900	0042-CABOA	17910.KVK.900
0006-CABOV	44830.GCE.9000	0020-CABOV	032INS0023	0043-CABOA	17920.KVK.900
0007-CABOA	17910.KBW.9000	0021-CABOA	032GUI0003	0044-CABOA	17910.KVK.960
0007-CABOAF	17950.GN5.9800	0021-CABOA	042ACI0001	0045-CABOA	17920.KVK.960
0007-CABOE	22870.KFC.9000	0021-CABOE	042ACI0002	0046-CABOA	17910.KRE.9000
0007-CABOF	45450.KRE.900	0021-CABOF	45450.KVS.600	0047-CABOA	18D.26311.00
0007-CABOV	44830.KCC.9000	0021-CABOV	072INS0008	0048-CABOA	062.GUI.0013
0008-CABOA	17910.KBB.9000	0022-CABOA	072GUI0006	0049-CABOA	062.GUI.0014
0008-CABOAF	17950.KW1.900	0022-CABOE	-	0050-CABOA	17910.GN5.9000
0008-CABOE	22870.KEH.9300	0022-CABOF	45450.KWG.600	0051-CABOA	17920.KPE.9000
0008-CABOF	45450.KRM.850	0022-CABOV	D01531030000SI	0052-CABOA	17910.KWG.600
0008-CABOV	44830.KPF.9000	0023-CABOA	044ACI0002	0053-CABOA	17910.MCG.770
0009-CABOA	17910.KFC.9000	0023-CABOE	D02531690000SI	0054-CABOA	17920.MCG.0000
0009-CABOAF	17950.KW8.9000	0023-CABOF	18D.26341.00	0054-CABOV	17920.MCG.770
0009-CABOE	22870.KGA.B00	0023-CABOV	3491005310	0055-CABOA	062.GUI.0004
0009-CABOE	22870.KGA.B400	0024-CABOA	D03531610000SI	0056-CABOA	58300-45F32
0009-CABOF	-	0024-CABOE	5820005391	0057-CABOA	5RM.F6311.00
0009-CABOV	44830.GE2.7400	0024-CABOF	45450.GN5.9002	0058-CABOA	1S4.26311.00
0010-CABOA	022GUI0008	0024-CABOV	3494005300	0059-CABOA	2D5.F6311.10
0010-CABOA	17910.GCE.9000	0025-CABOA	D02531700000SI	0060-CABOA	31S.F6301.00
0010-CABOAF	17950.KBB.9001	0025-CABOE	-	0061-CABOA	2D5.F6311.10
0010-CABOE	22870.KSM.900	0025-CABOF	45450.KGA.000	0061-CABOA	5LW.F6311.02
0010-CABOF	45450.KSS.900	0025-CABOV	3494005311	0062-CABOA	21D.26311.00
0010-CABOF	45450.KSS.C00	0026-CABOA	D06531020000SI	0063-CABOA	17920.MCG.0000
0010-CABOV	44830.KY7.0000	0026-CABOE	22870.GFP.900	0064-CABOA	4B4.26302.00
0011-CABOA	17910.KPF.9000	0026-CABOF	45450.KSS.C00	0065-CABOA	17910.MCG.0000
0011-CABOAF	-	0026-CABOV	34910.20E20	0066-CABOA	-
0011-CABOE	22870.KRM.860	0027-CABOA	5830005302	0066-CABOA	17920.KPS.900
0011-CABOF	5HH.F6341.01	0027-CABOE	22870.KVS.600	0067-CABOA	-
0011-CABOV	44830.KRM.860	0027-CABOV	-	0068-CABOA	17910.KPS.900
0011-CABOV	44830.KWG.600	0028-CABOA	58300-45F32	0069-CABOA	-
0012-CABOA	17920.KPF.9000	0028-CABOA	58300.45F10	0069-CABOA	17910.KPS.900
0012-CABOE	22870.397.0000	0028-CABOE	22870.KWG.600	0070-CABOA	17910.KSS.C00
0012-CABOF	022GUI0009	0028-CABOV	44830.KSS.B30	0071-CABOA	17910.KVS.890
0012-CABOV	44830.KSS.900	0029-CABOA	-	0072-CABOA	17920-KVK-841
0013-CABOA	17910.KSM.900	0029-CABOE	22870.KRE.B00		

# Desenhos **Técnicos** Pastilhas

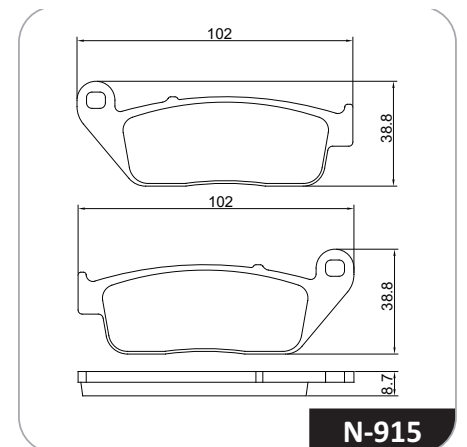
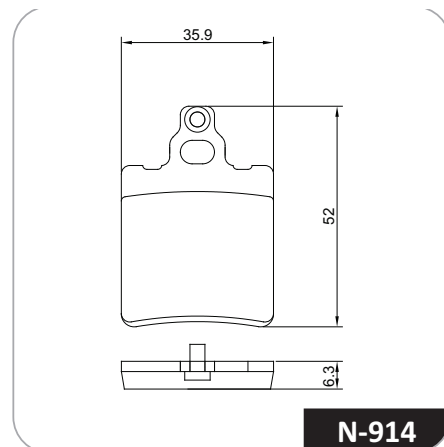
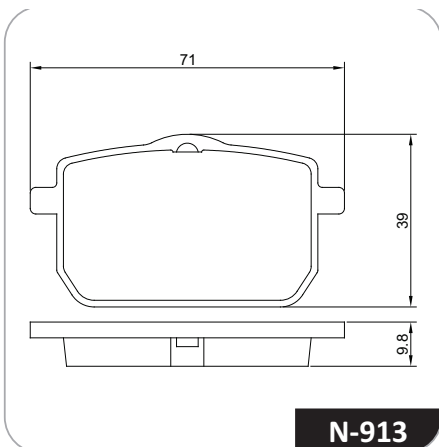
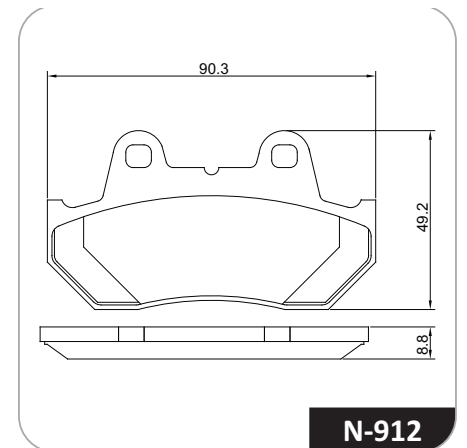
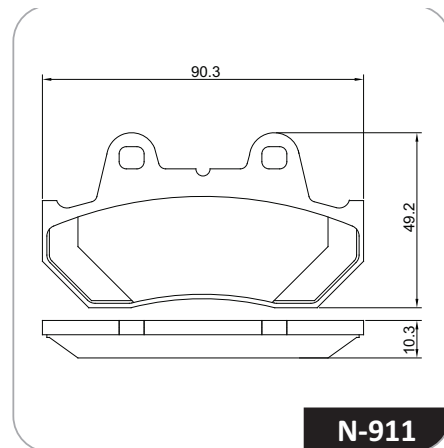
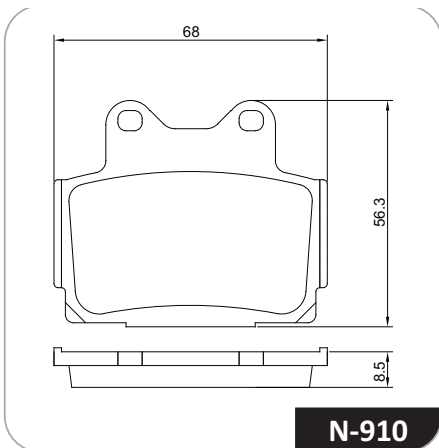
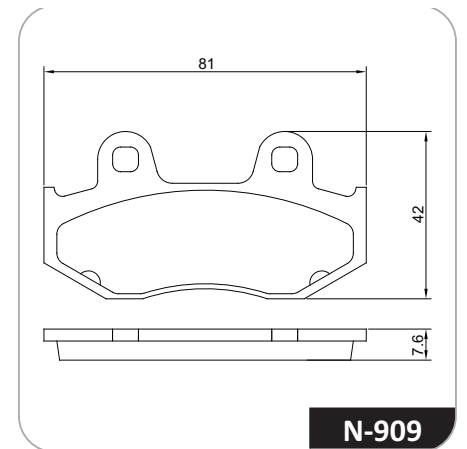
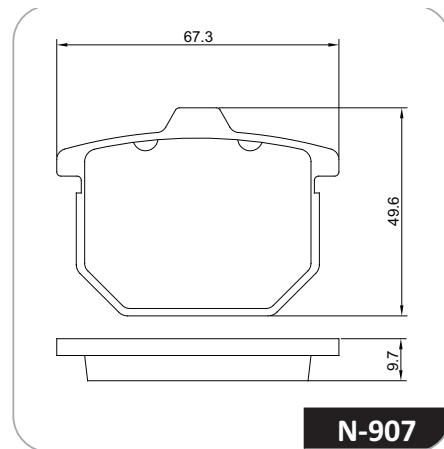
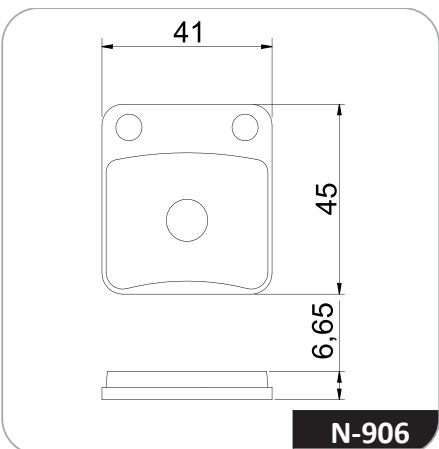
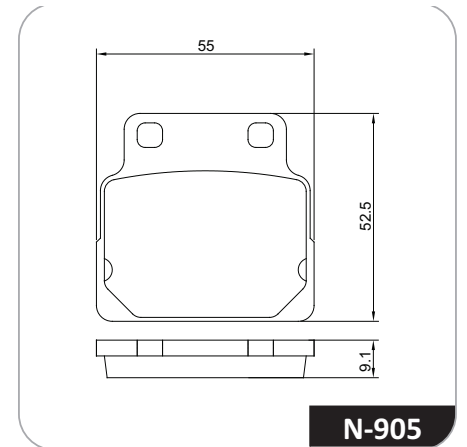
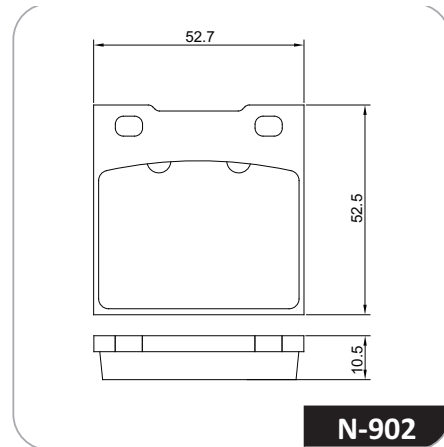
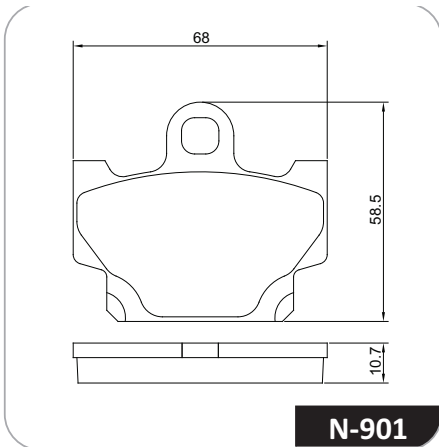

# Desenhos **Técnicos** Pastilhas

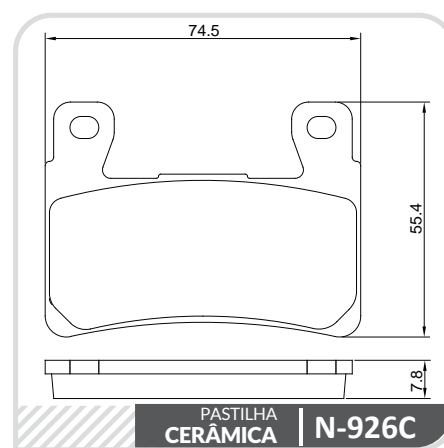
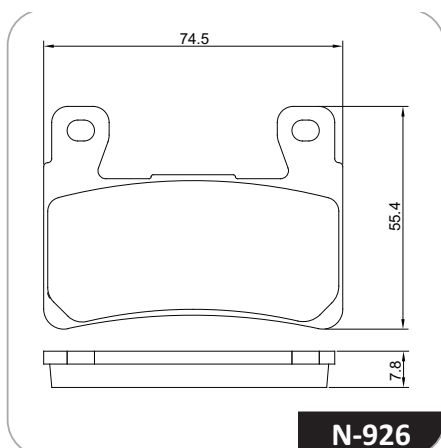
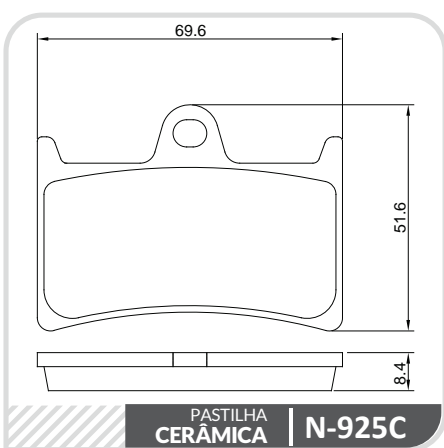
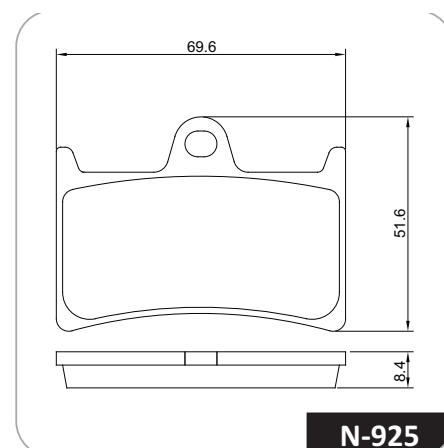
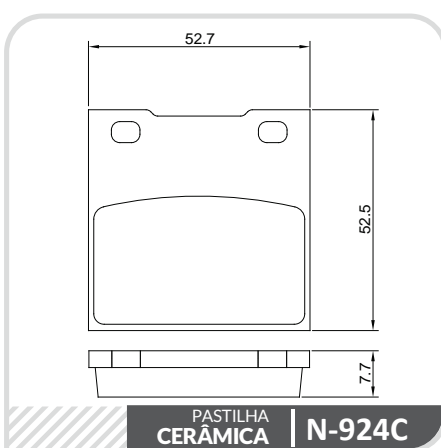
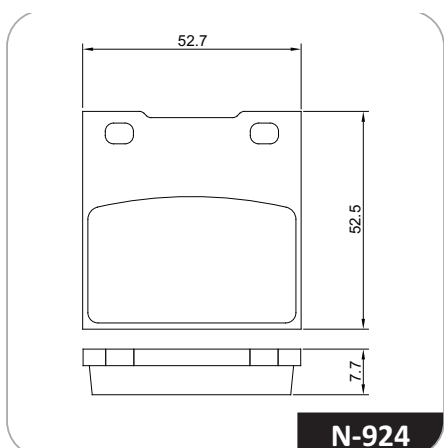
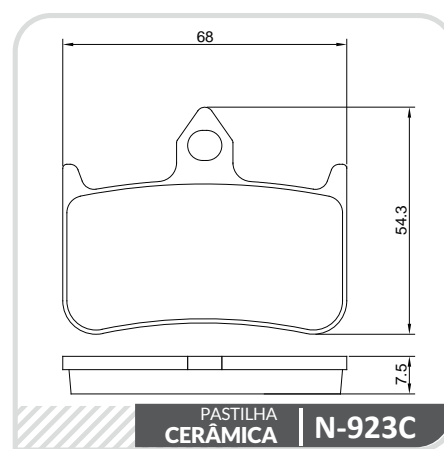
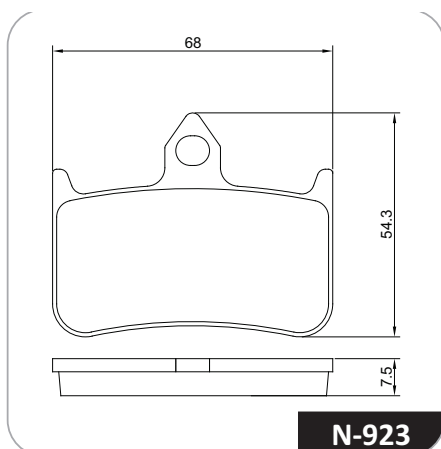
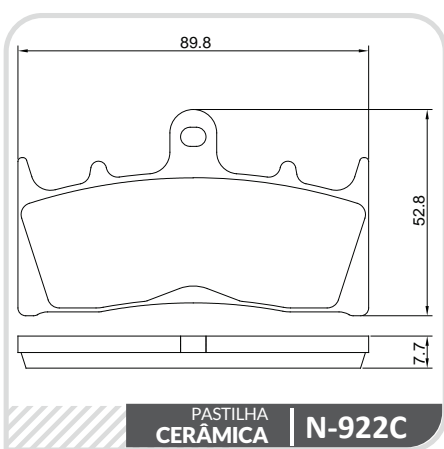
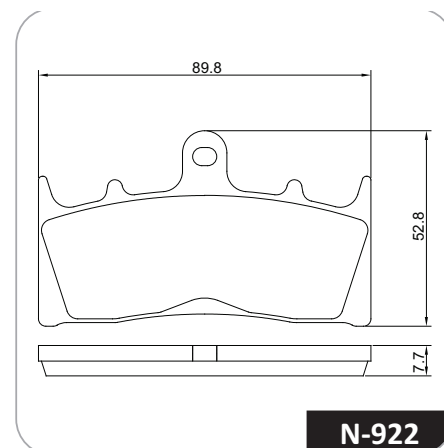
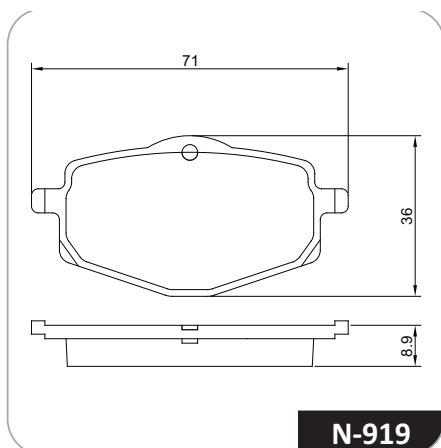
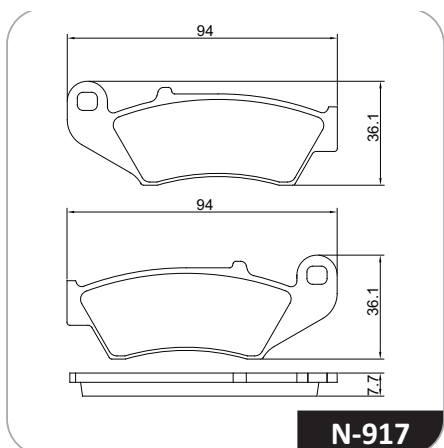

# Desenhos Técnicos Pastilhas

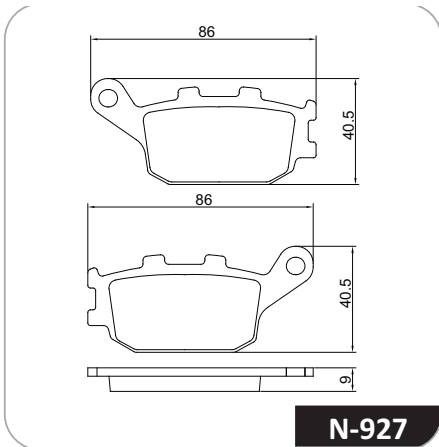

**N-927**

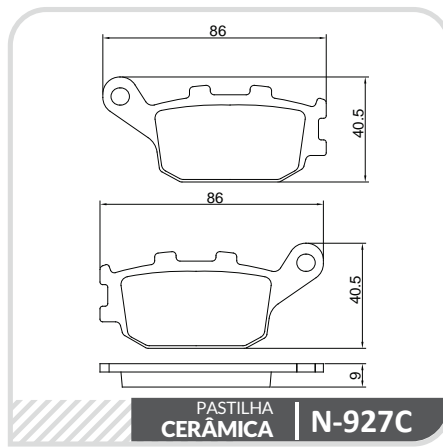

PASTILHA CERÂMICA | **N-927C**

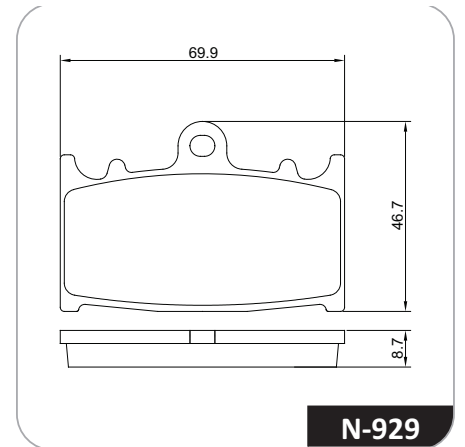

**N-929**



PASTILHA CERÂMICA | **N-929C**

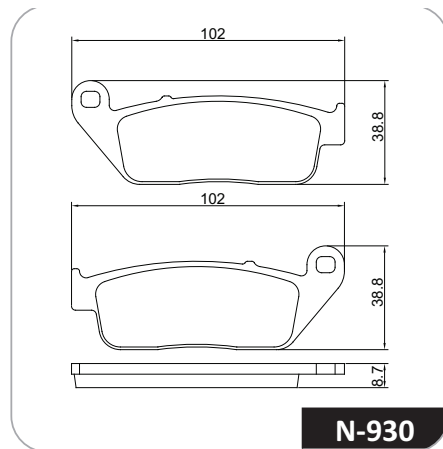

**N-930**



PASTILHA CERÂMICA | **N-930C**

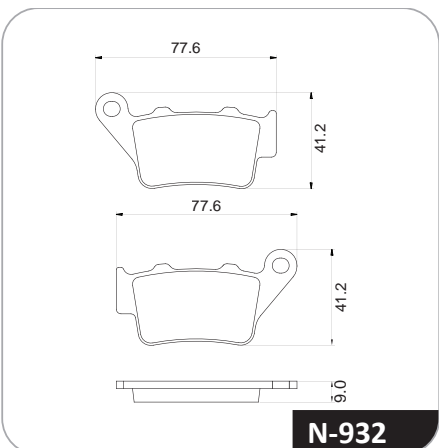

**N-932**

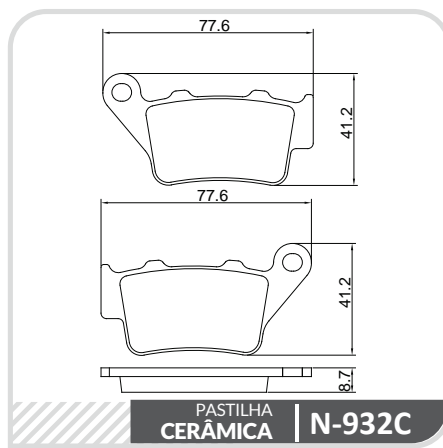

PASTILHA CERÂMICA | **N-932C**

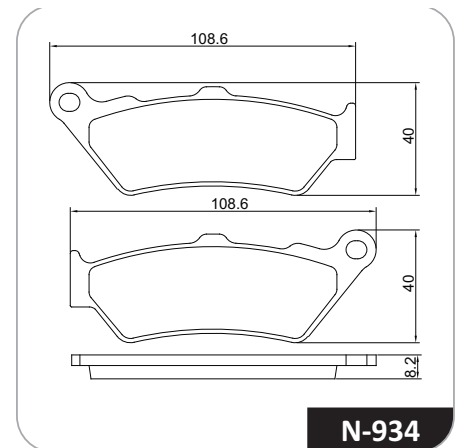

**N-934**



PASTILHA CERÂMICA | **N-934C**

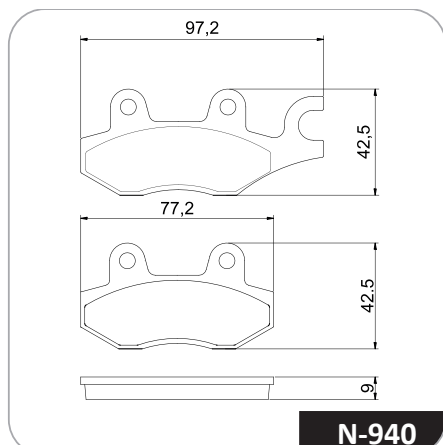

**N-940**

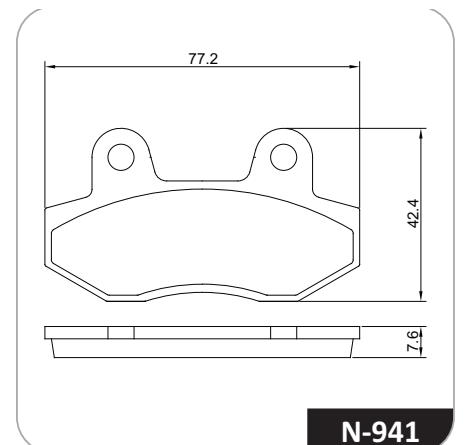

**N-941**

# Desenhos Técnicos Pastilhas

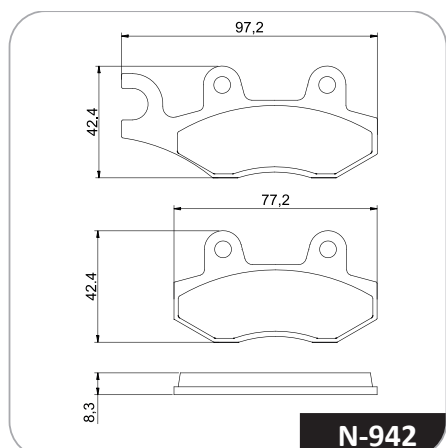

**N-942**

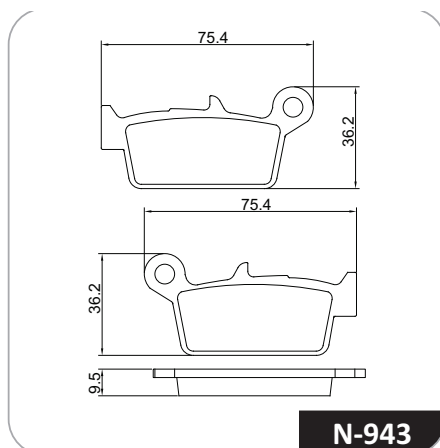

**N-943**

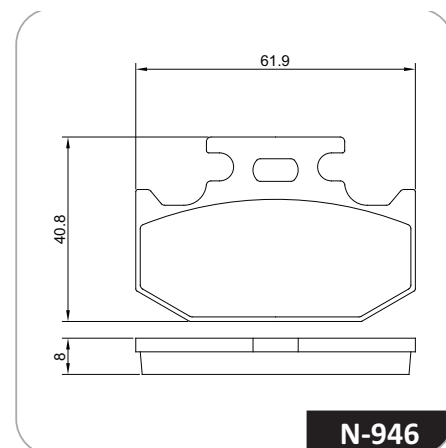

**N-946**

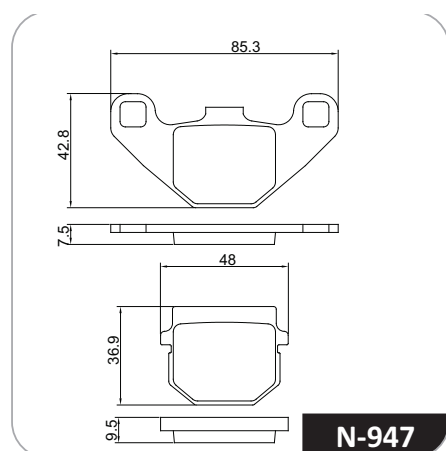

**N-947**

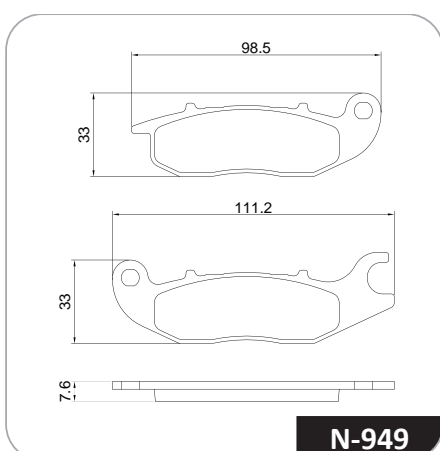

**N-949**

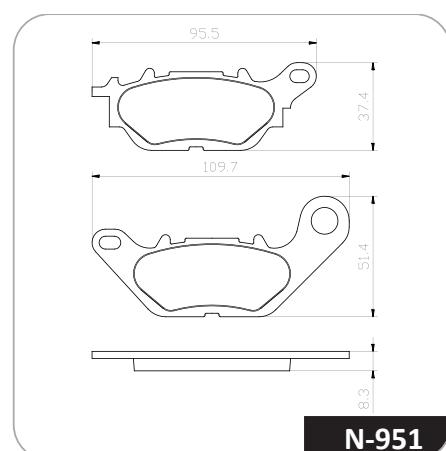

**N-951**

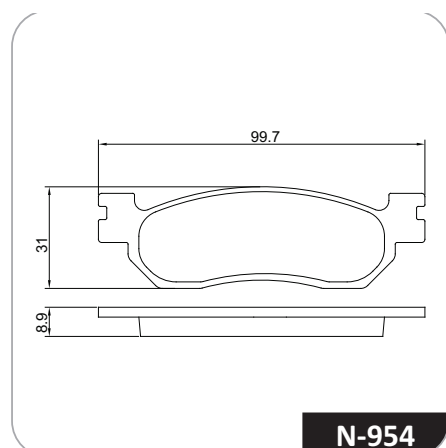

**N-954**

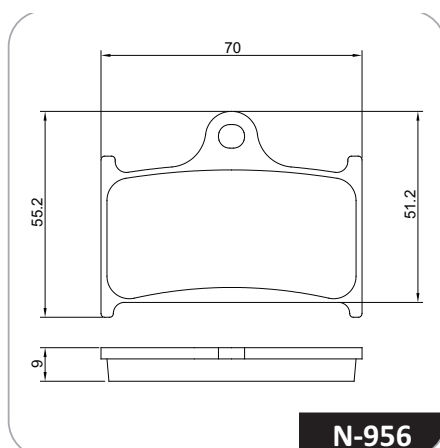

**N-956**

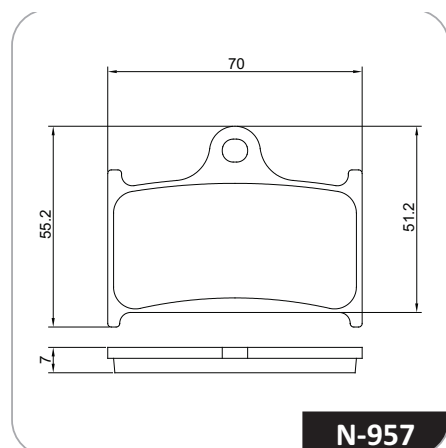
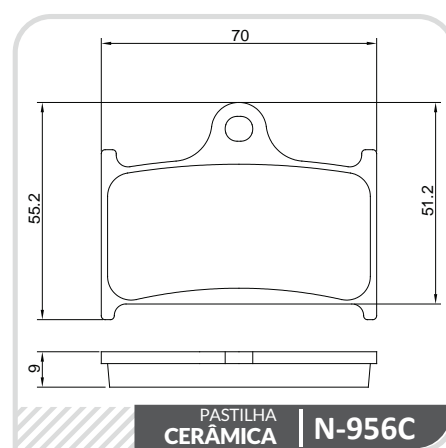

**N-957**

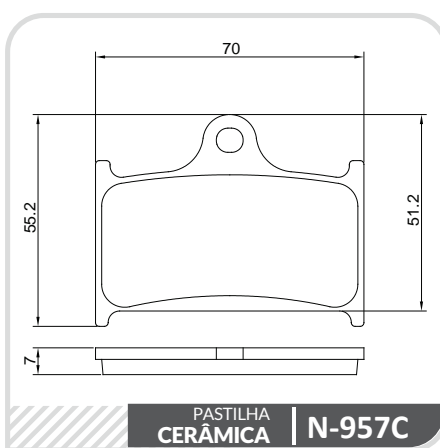

**PASTILHA CERÂMICA | N-957C**

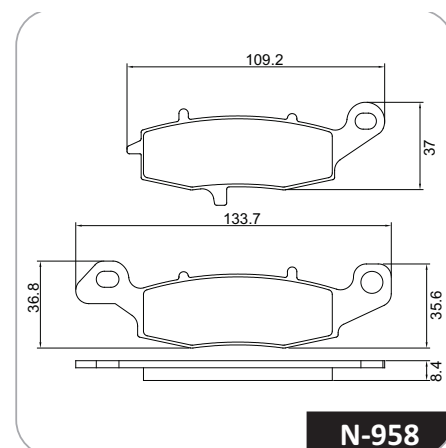

**N-958**

# Desenhos **Técnicos** Pastilhas

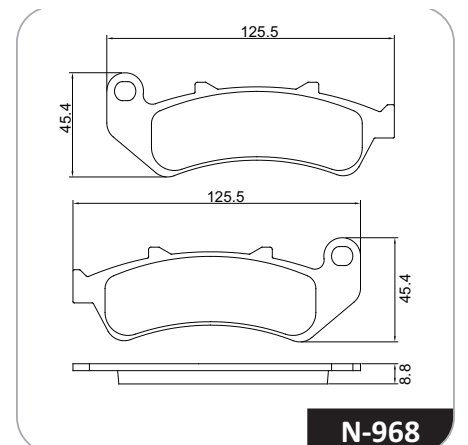
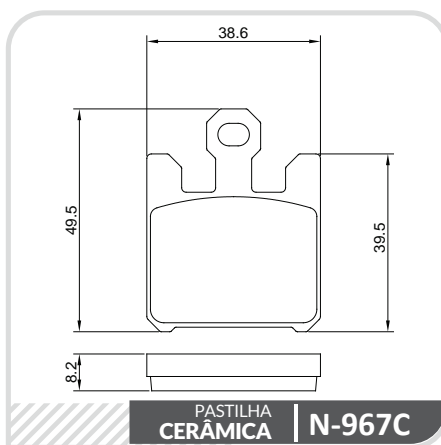
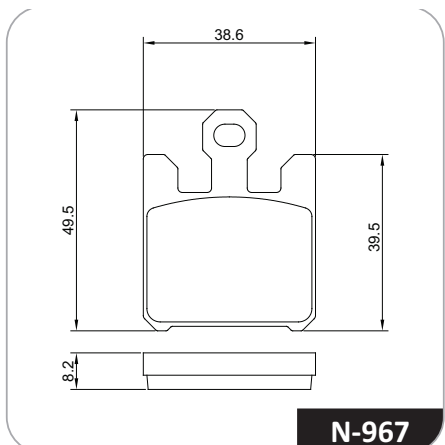
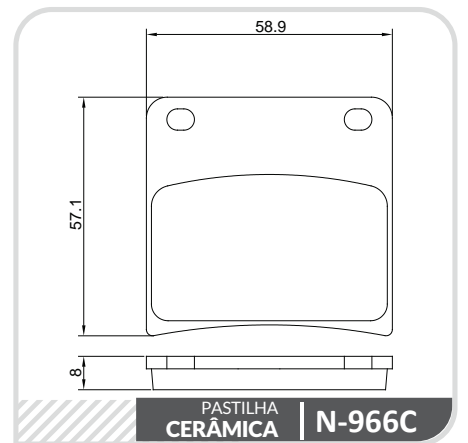
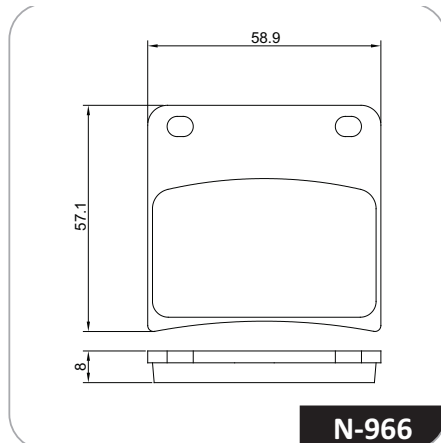
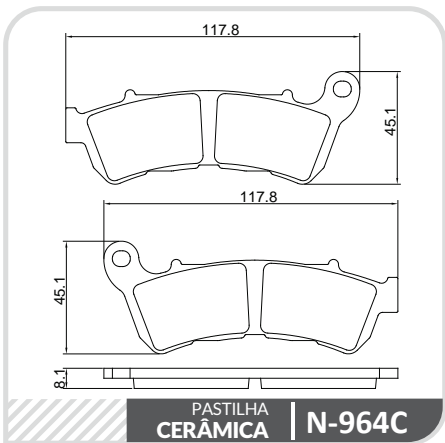
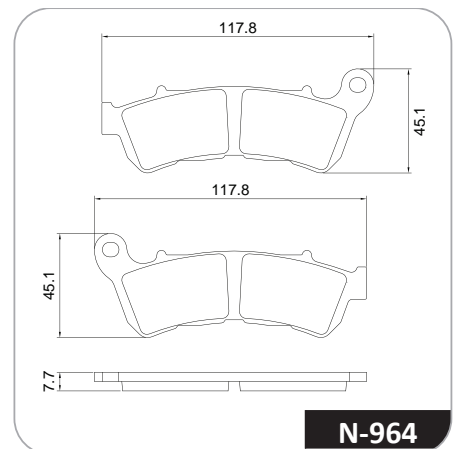
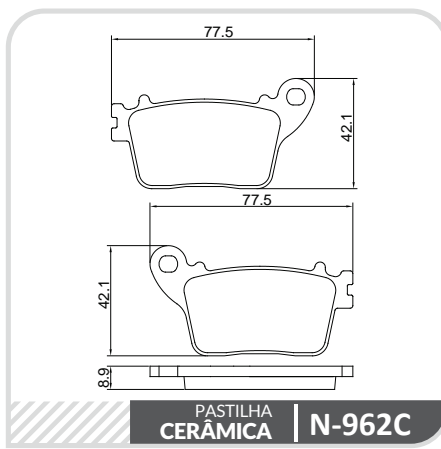
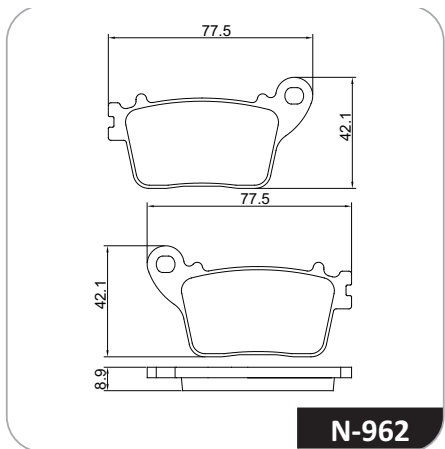
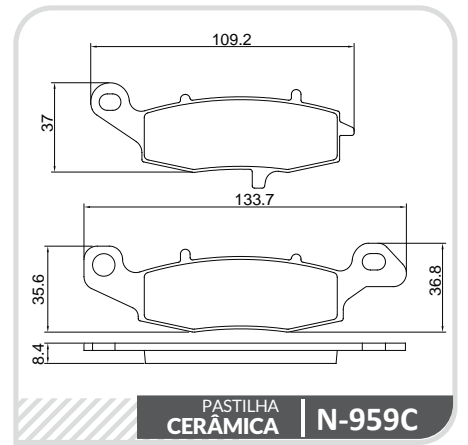
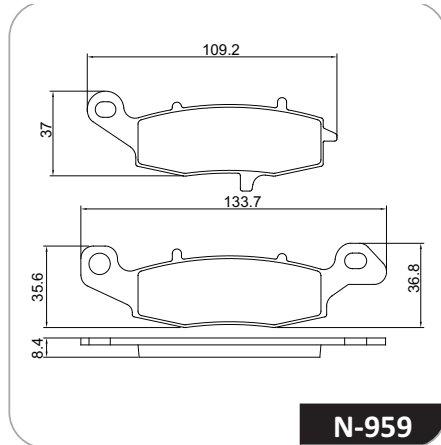
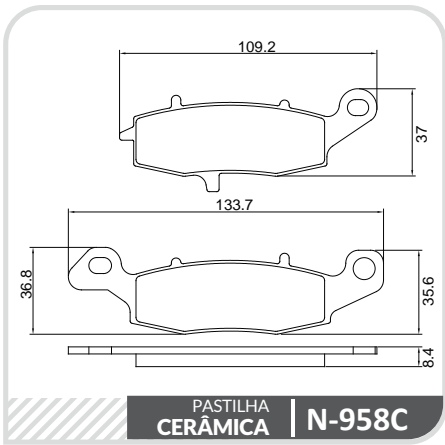

# Desenhos Técnicos Pastilhas

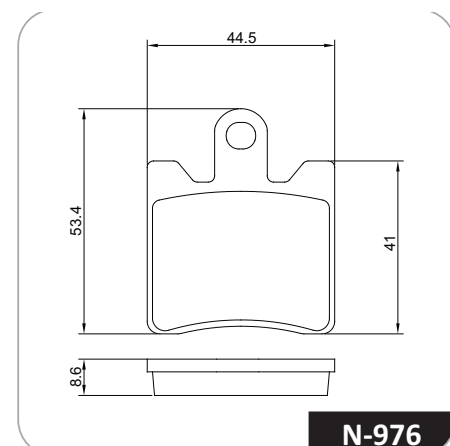
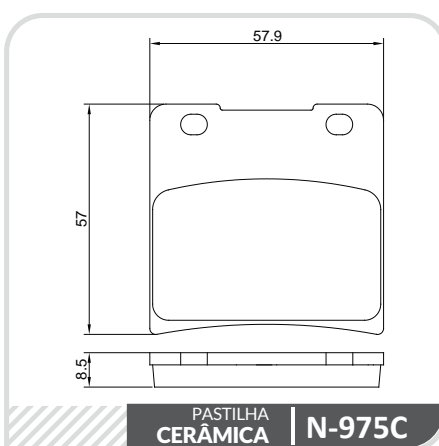
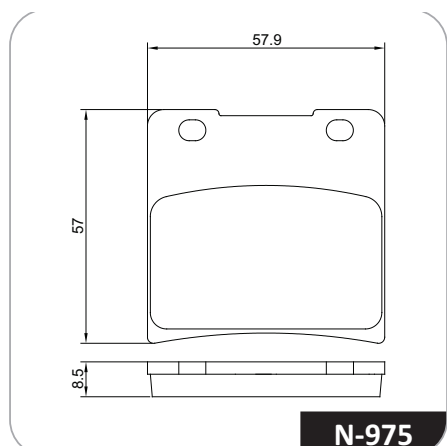
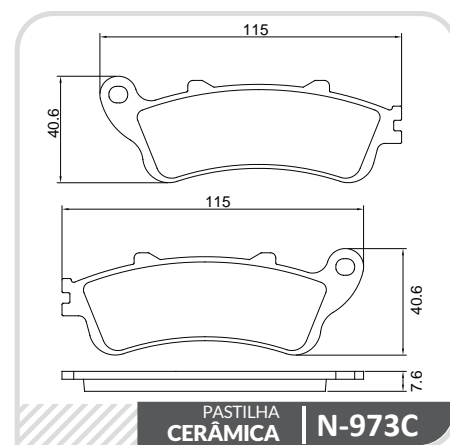
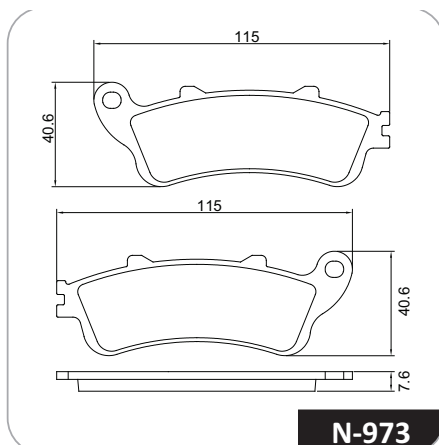
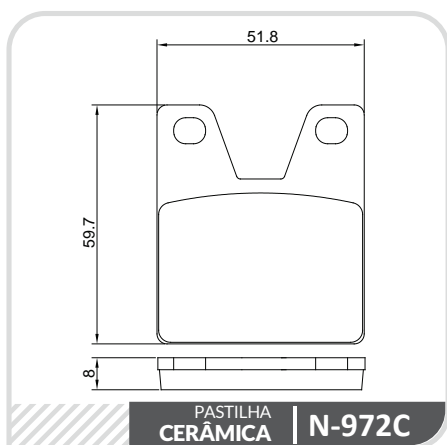
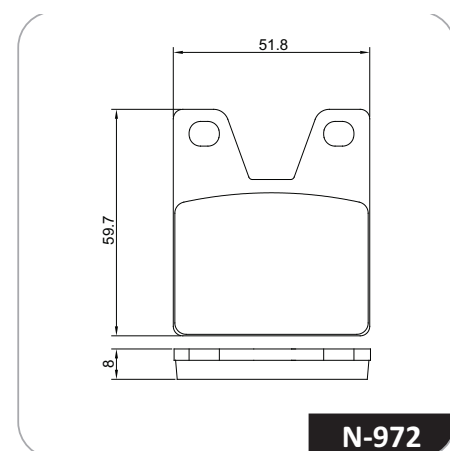
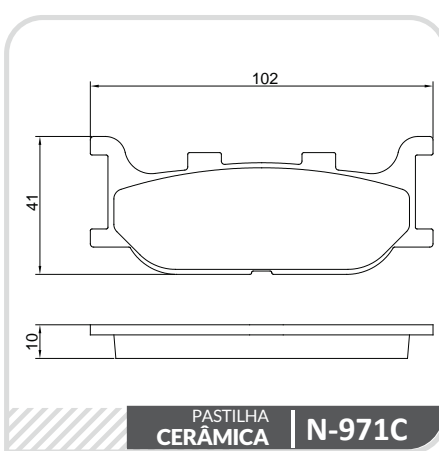
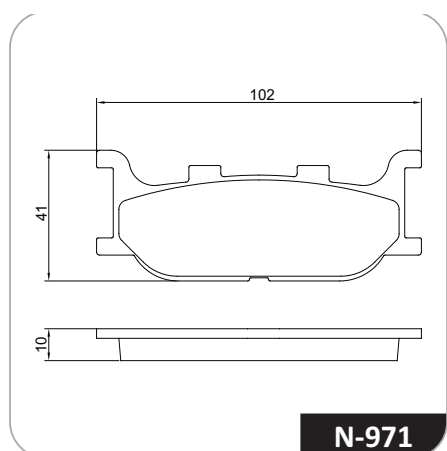
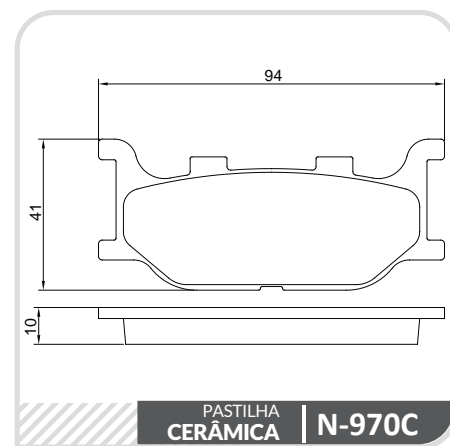
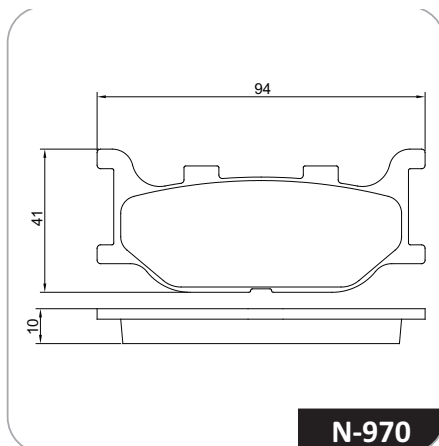

# Desenhos Técnicos Pastilhas

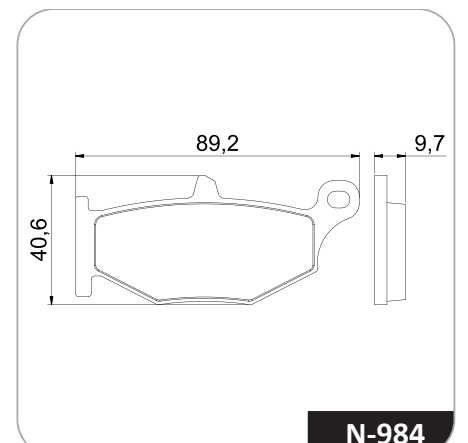
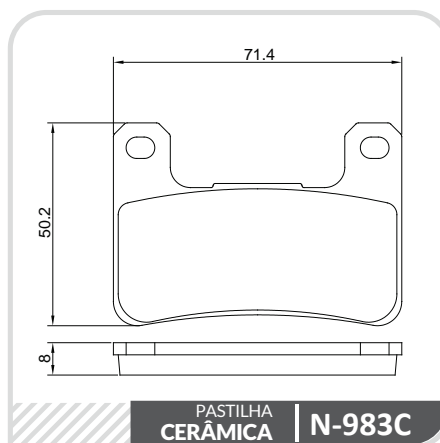
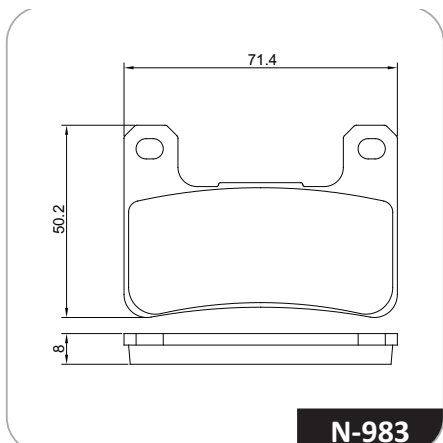
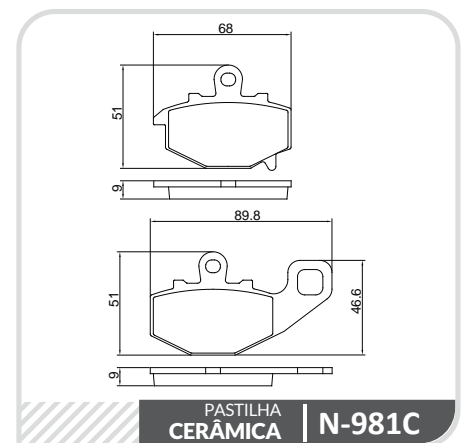
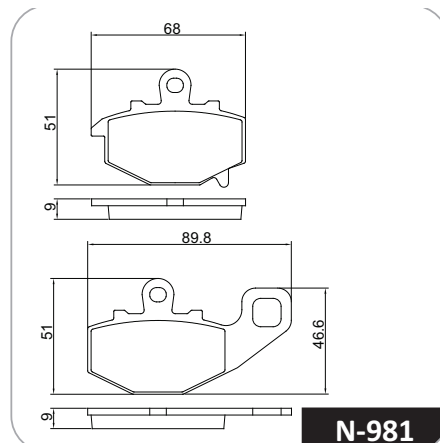
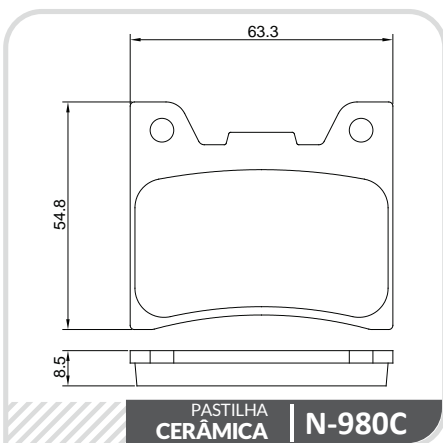
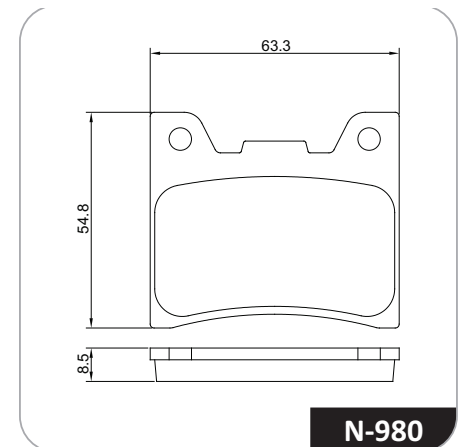
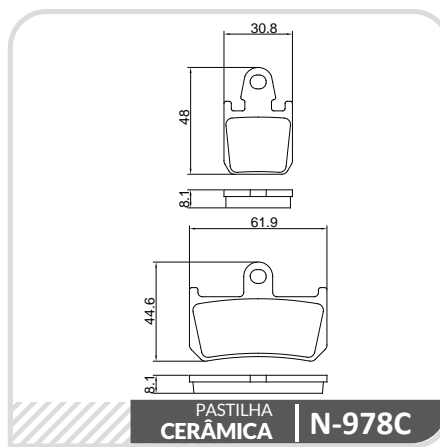
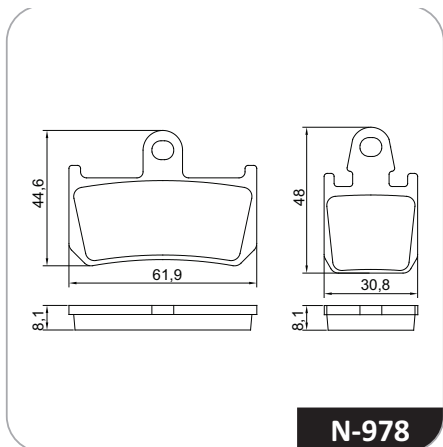
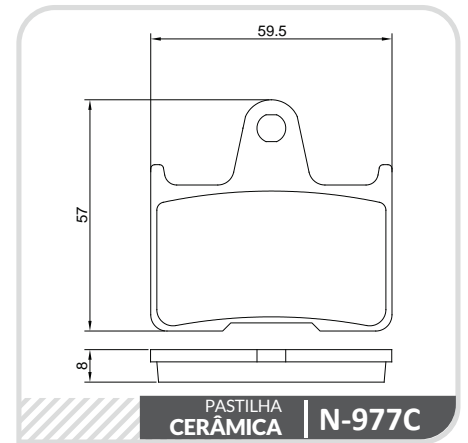
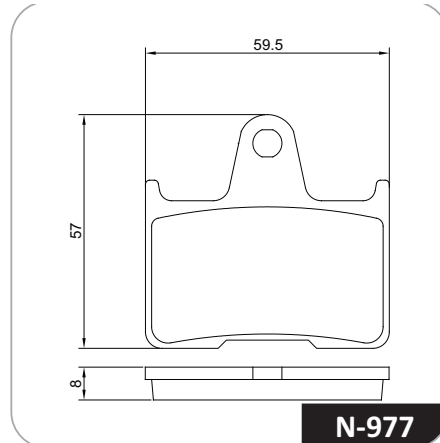
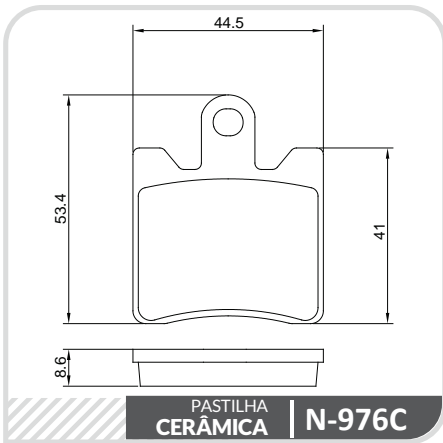

# Desenhos Técnicos Pastilhas

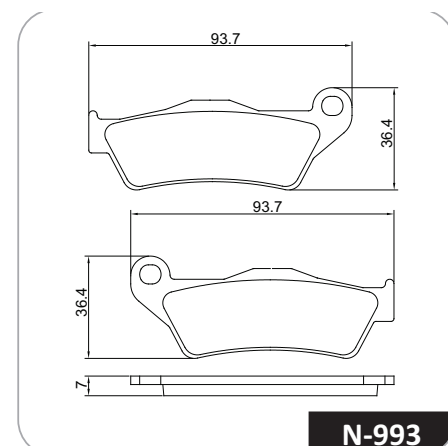
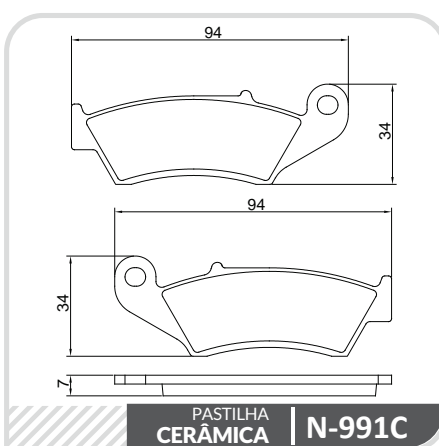
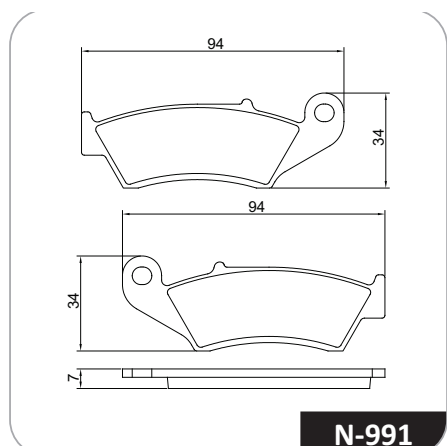
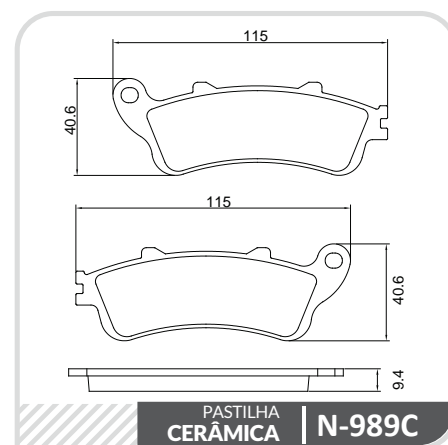
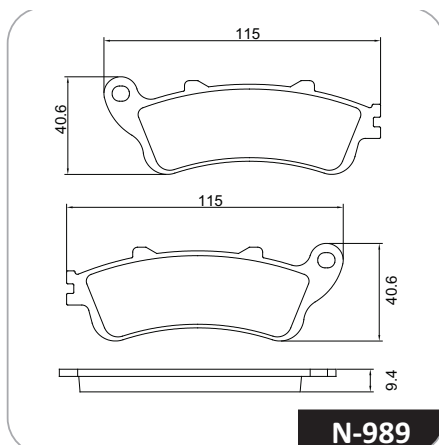
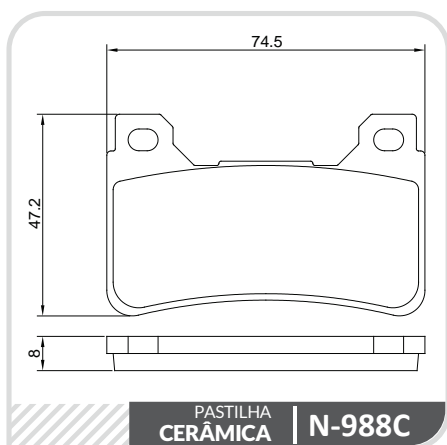
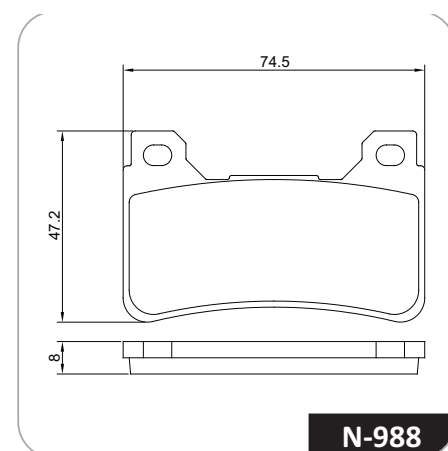
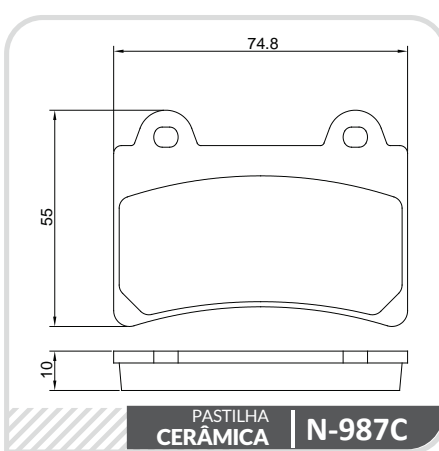
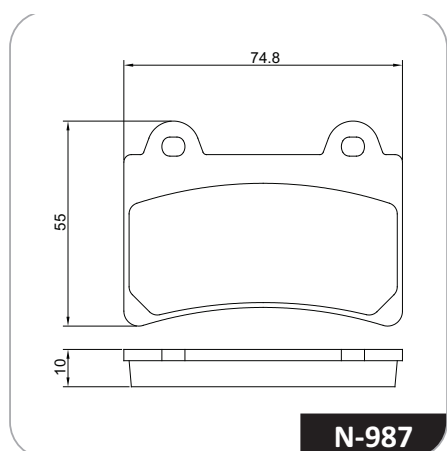
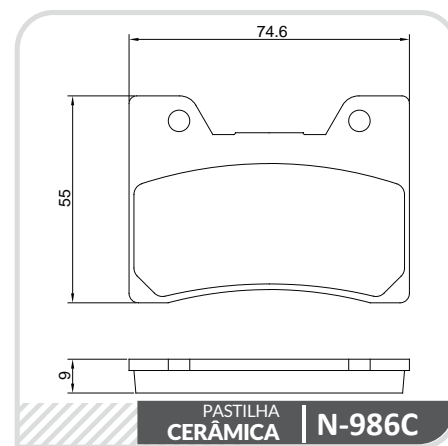
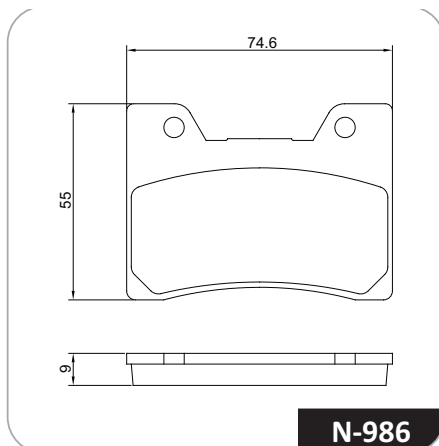
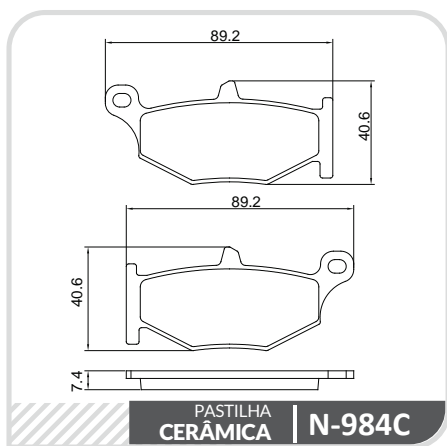

# Desenhos Técnicos Pastilhas

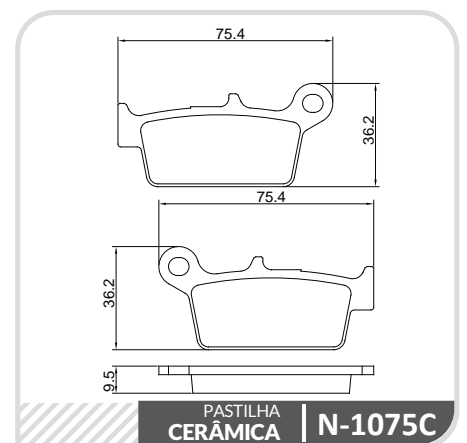
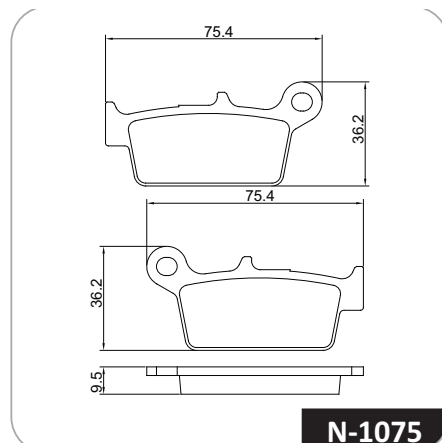
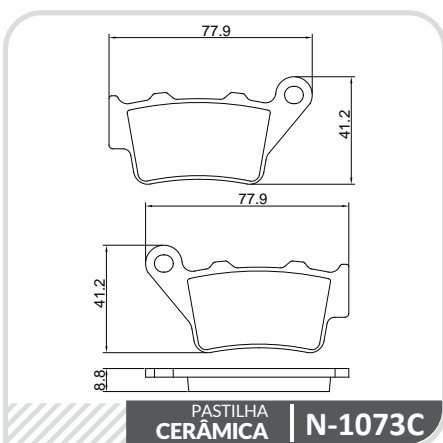
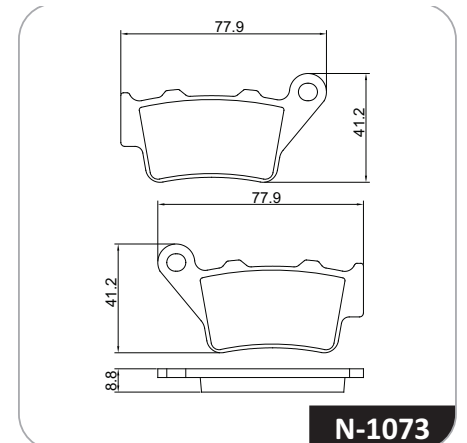
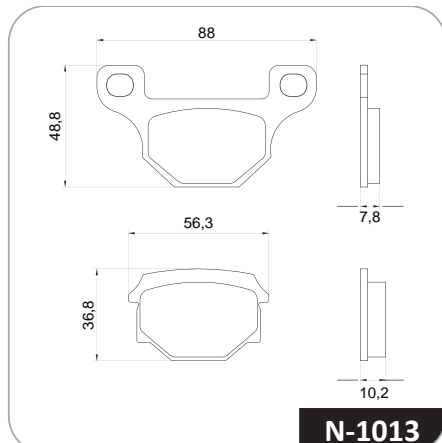
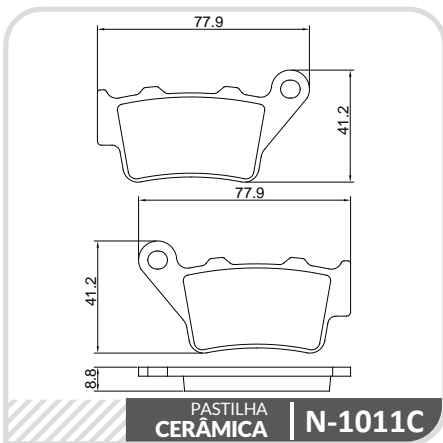
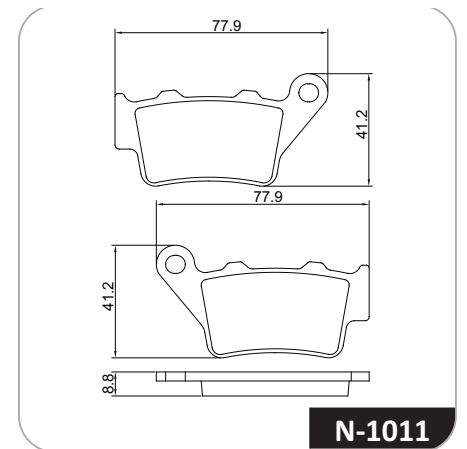
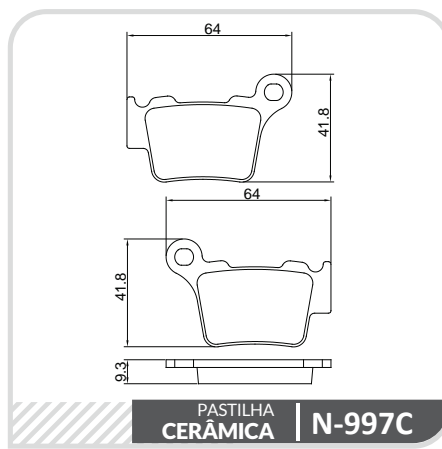
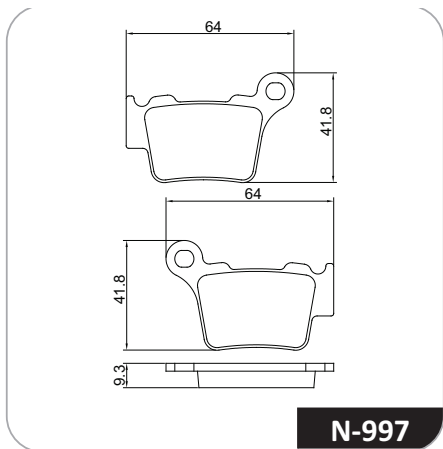
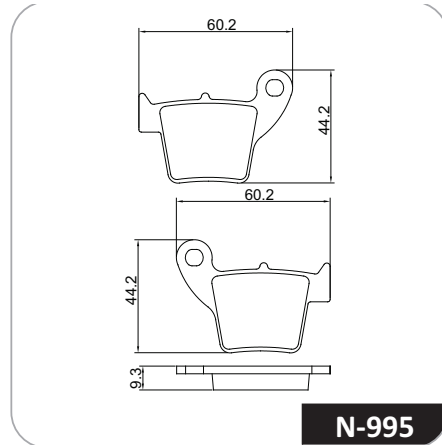
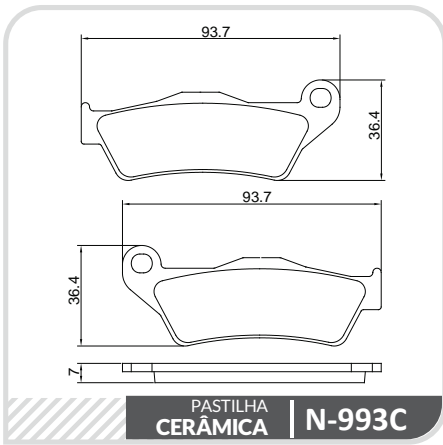

# Desenhos Técnicos Pastilhas

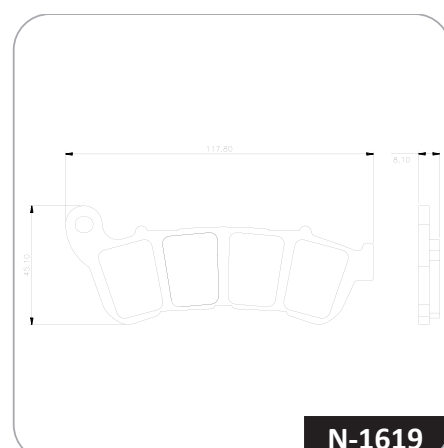
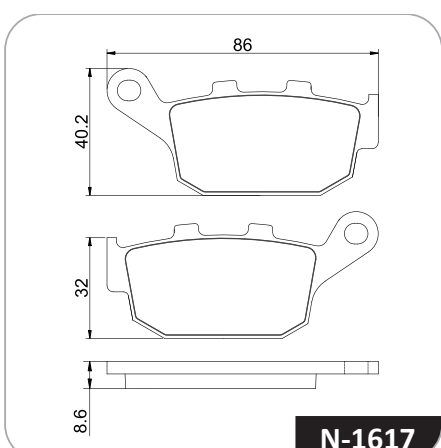
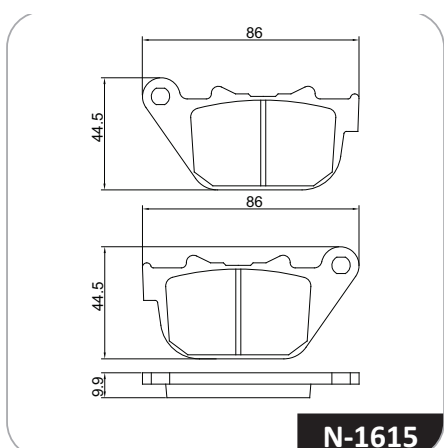
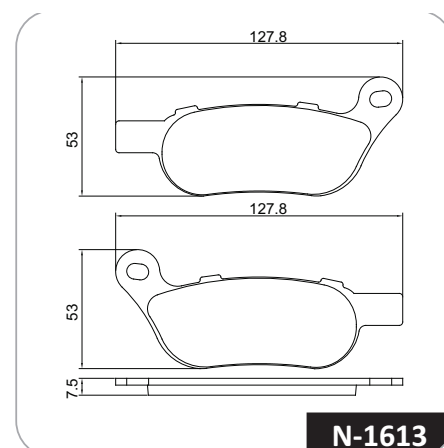
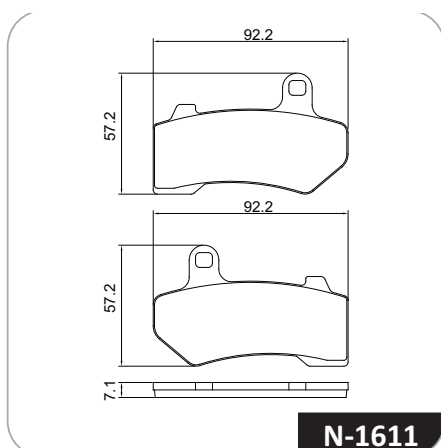
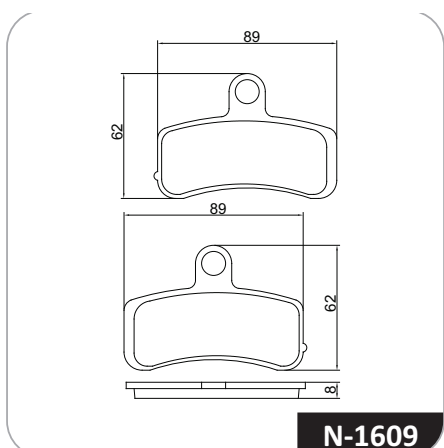
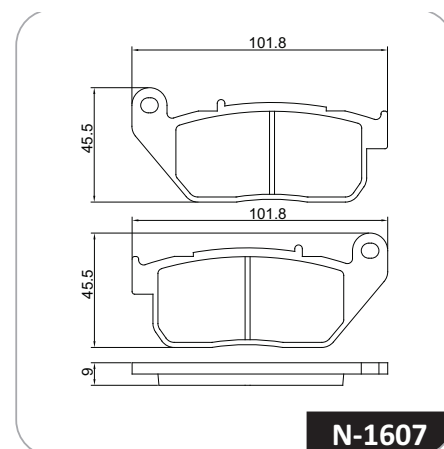
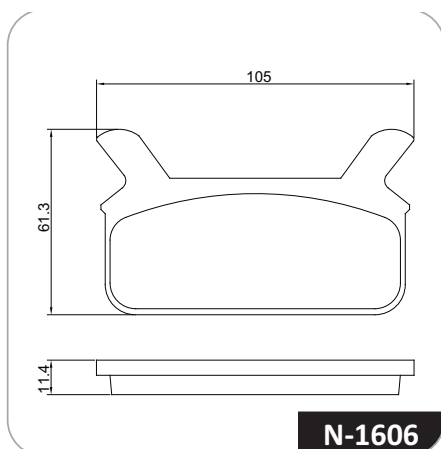
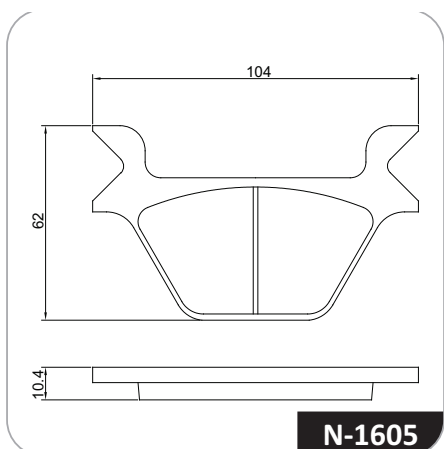
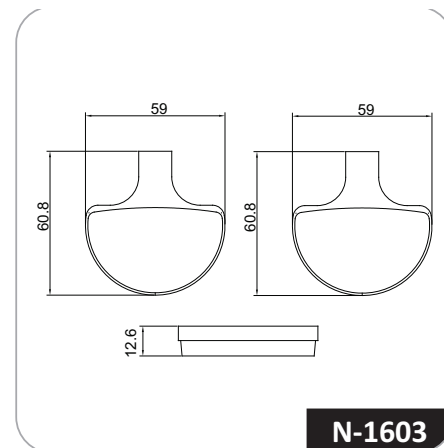
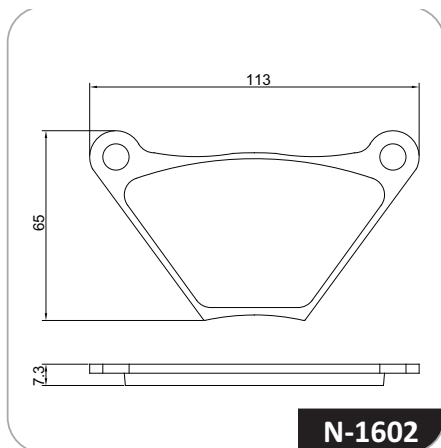
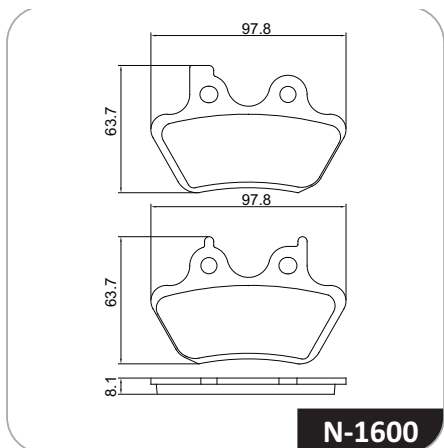

# Desenhos Técnicos Pastilhas

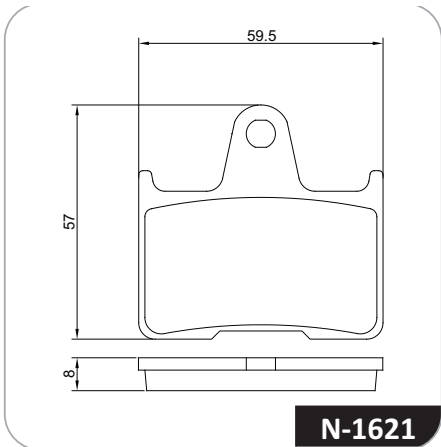

**N-1621**

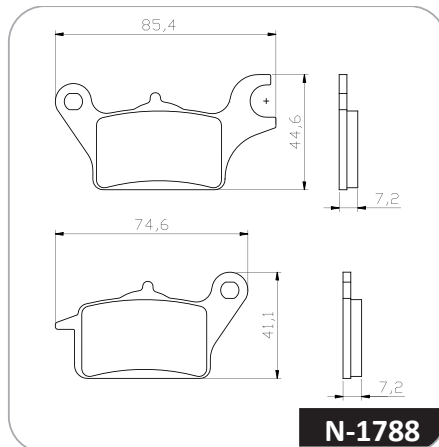

**N-1788**

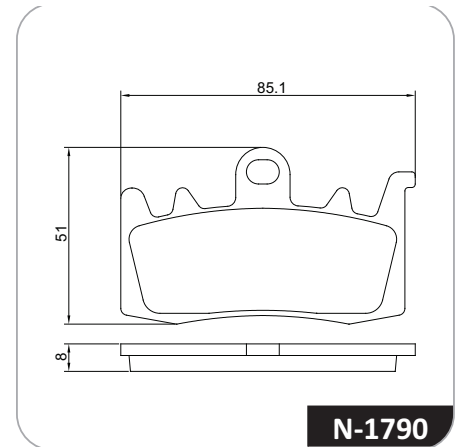

**N-1790**

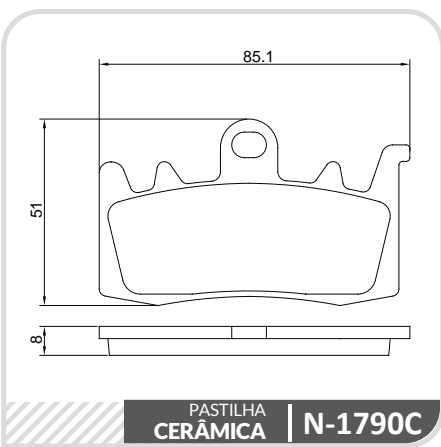

PASTILHA CERÂMICA | **N-1790C**

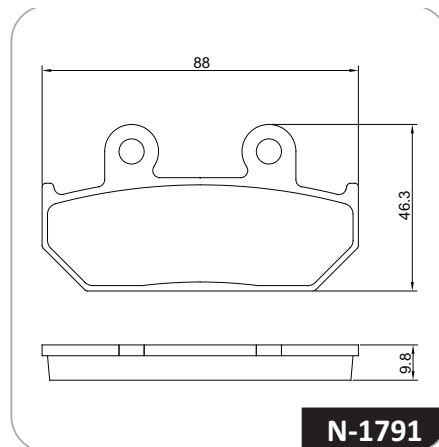

**N-1791**

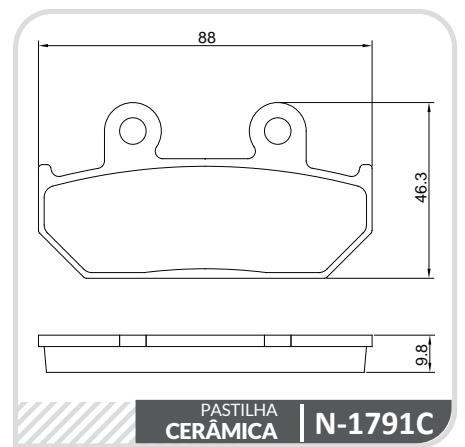

PASTILHA CERÂMICA | **N-1791C**

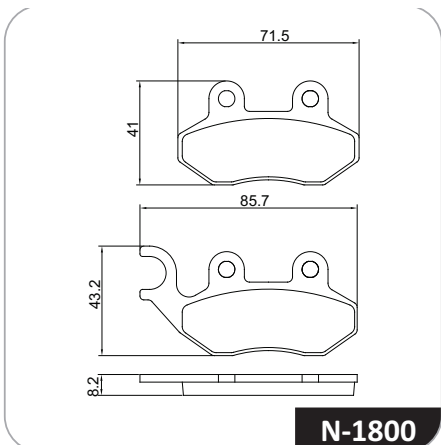

**N-1800**

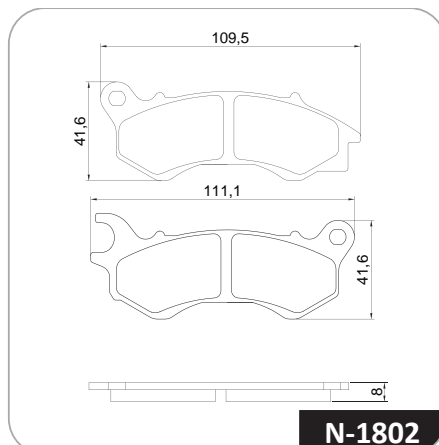

**N-1802**

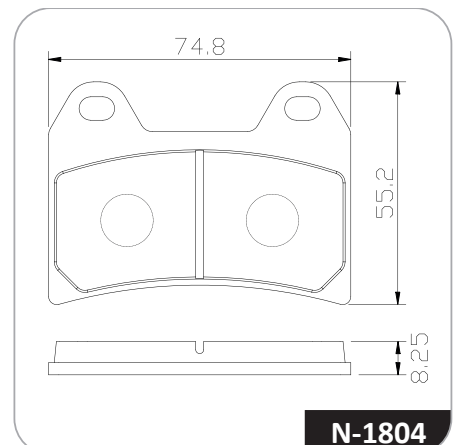

**N-1804**

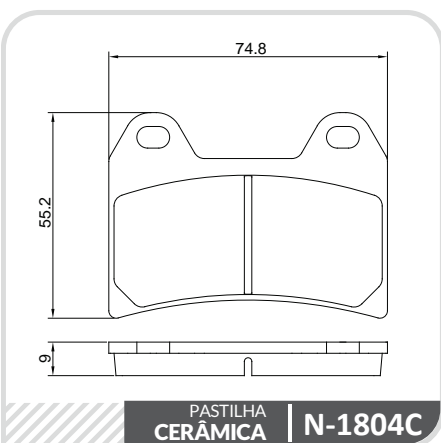

PASTILHA CERÂMICA | **N-1804C**

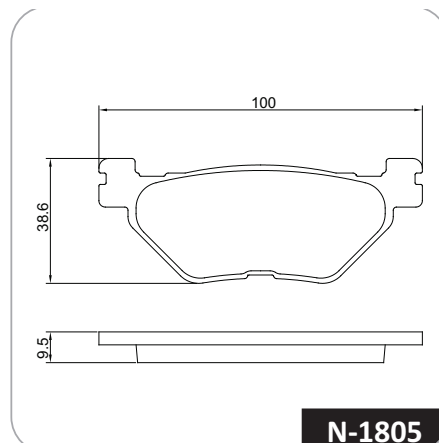

**N-1805**

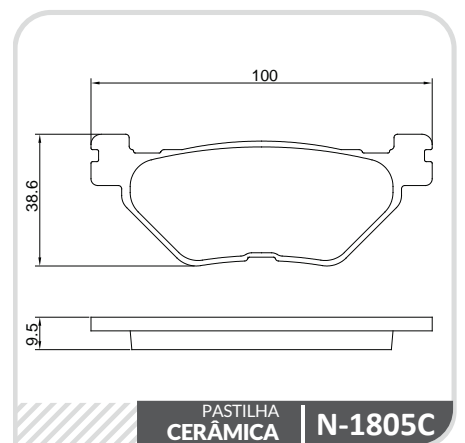

PASTILHA CERÂMICA | **N-1805C**

# Desenhos Técnicos Pastilhas

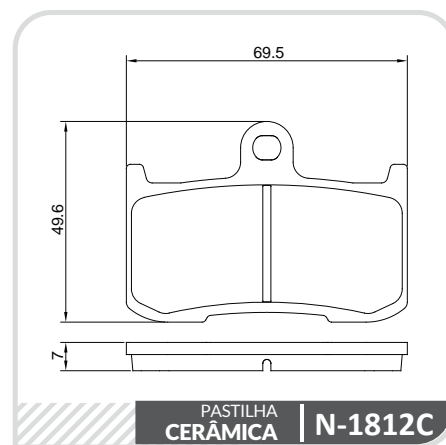
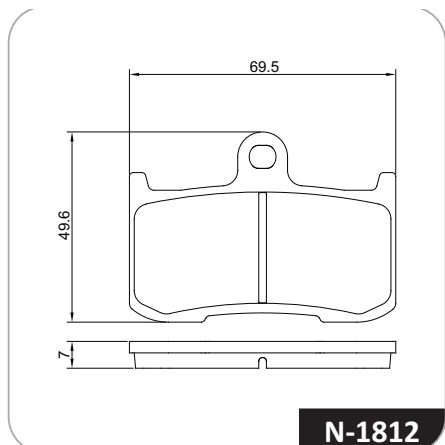
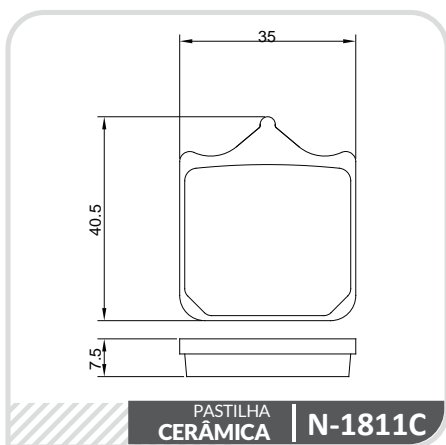
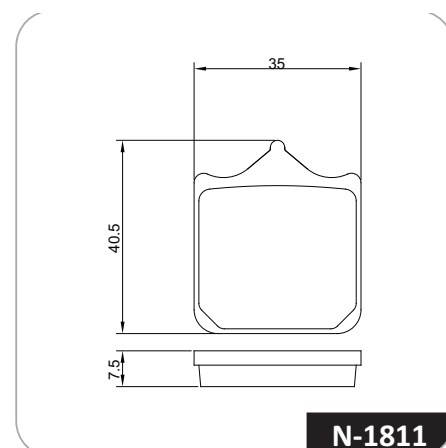
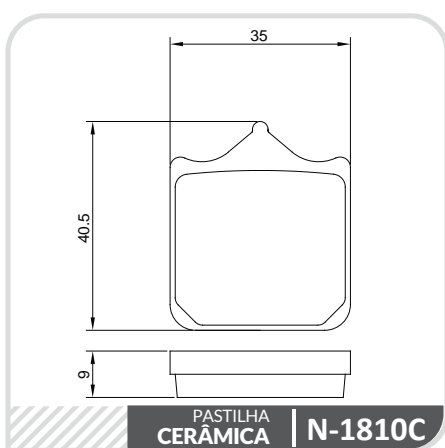
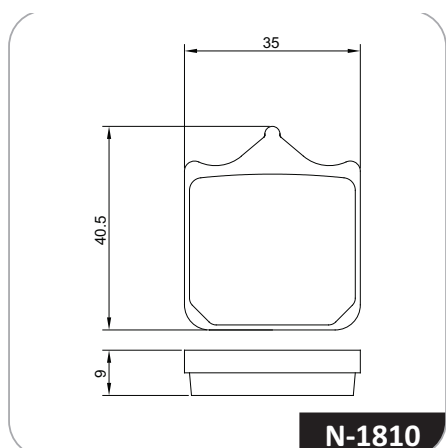
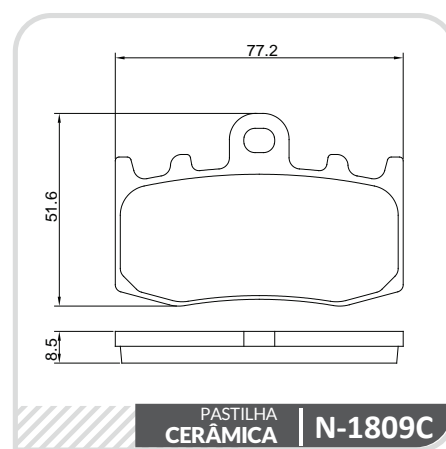
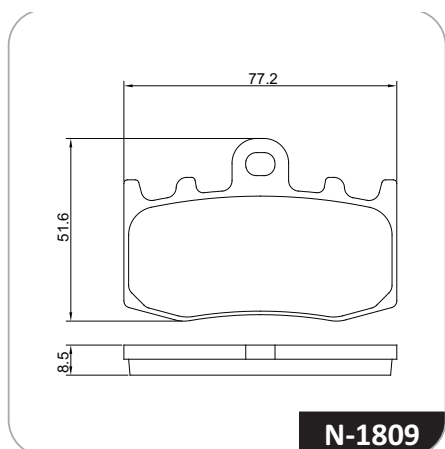
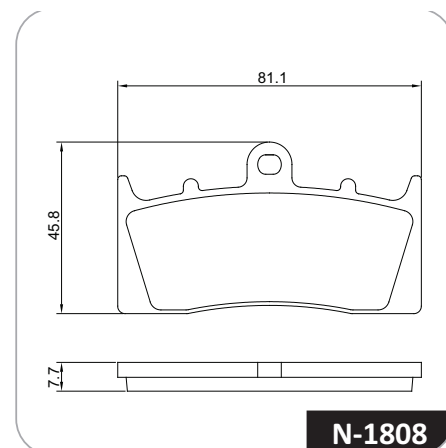
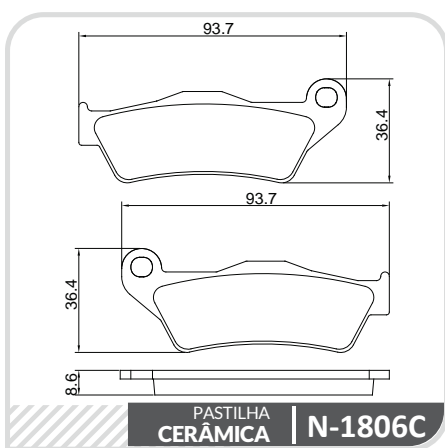
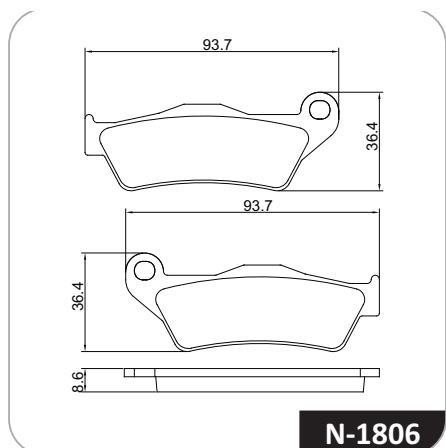

# Desenhos Técnicos Pastilhas

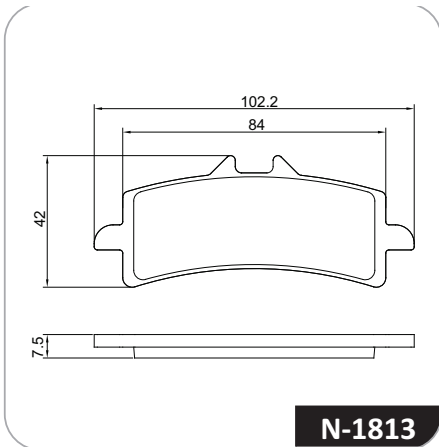

**N-1813**

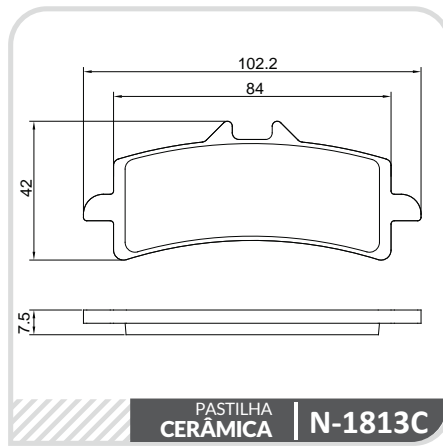

PASTILHA CERÂMICA | **N-1813C**

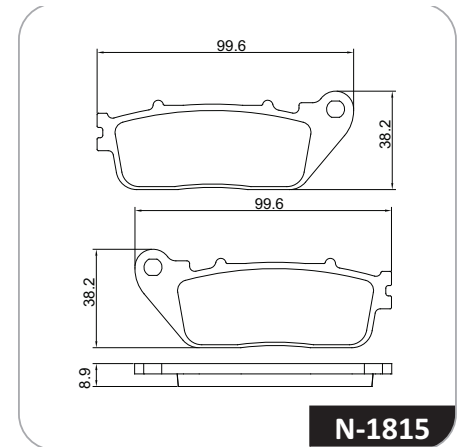

**N-1815**

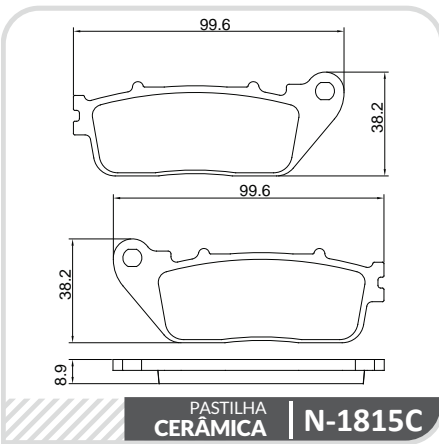

PASTILHA CERÂMICA | **N-1815C**

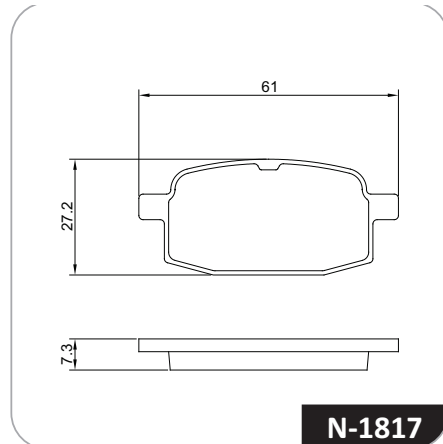

**N-1817**

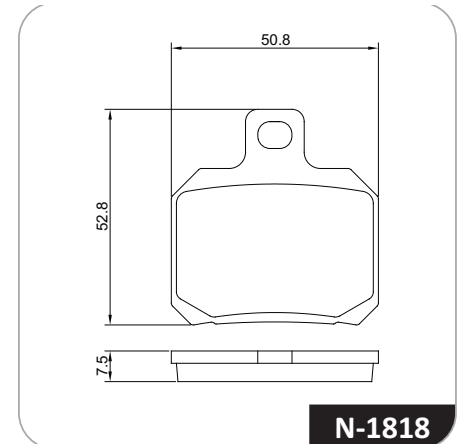

**N-1818**



PASTILHA CERÂMICA | **N-1818C**

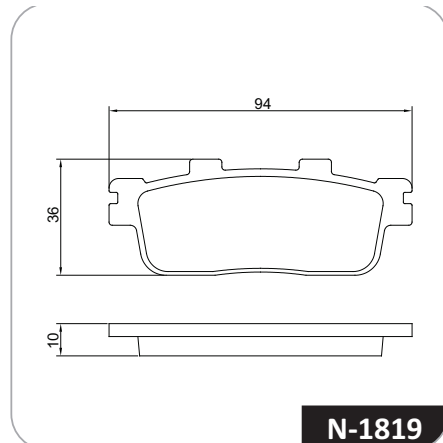

**N-1819**

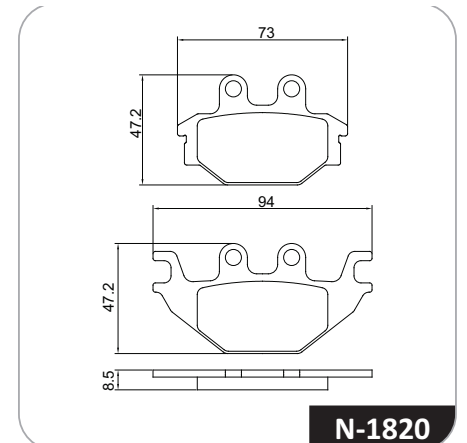

**N-1820**

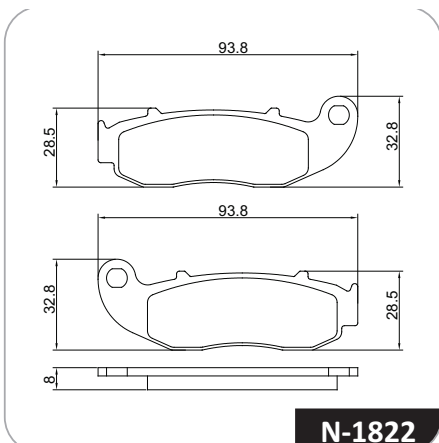

**N-1822**



PASTILHA CERÂMICA | **N-1822C**

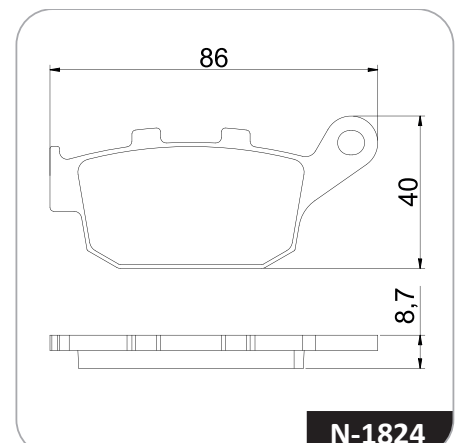

**N-1824**

# Desenhos **Técnicos** Pastilhas

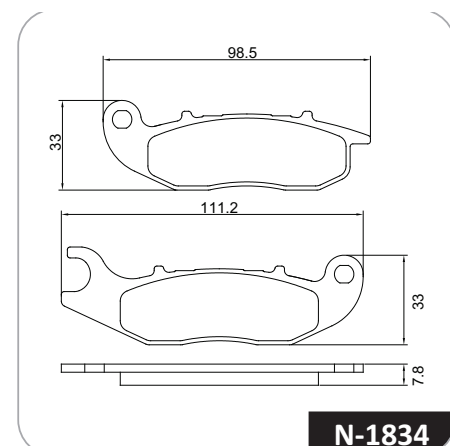
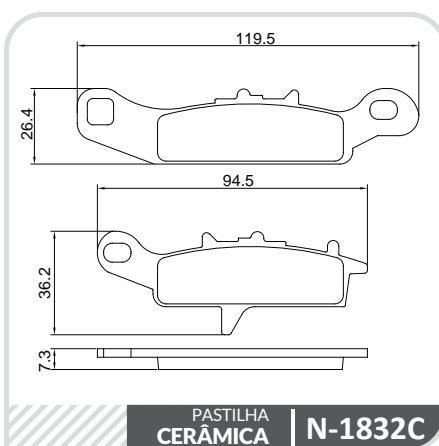
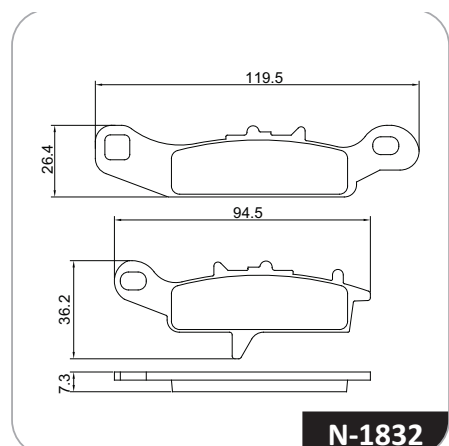
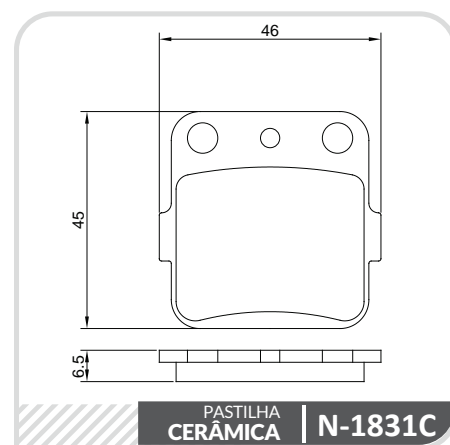
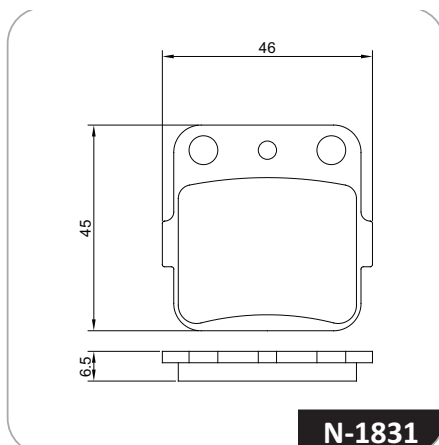
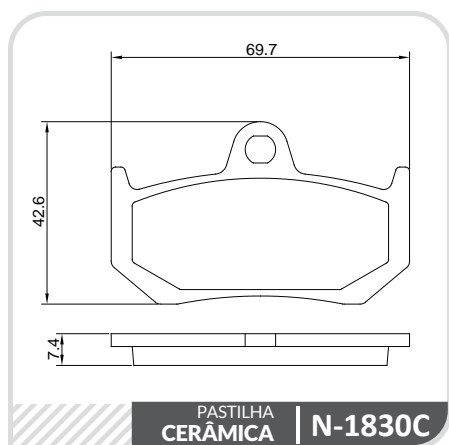
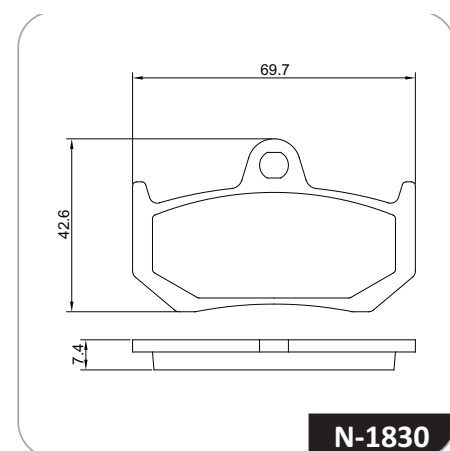
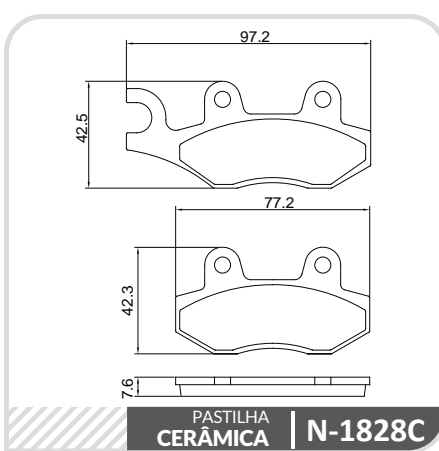
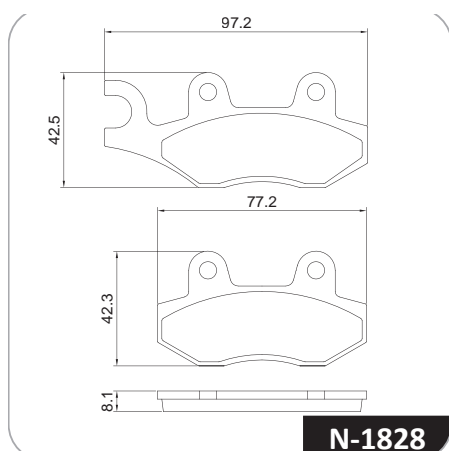
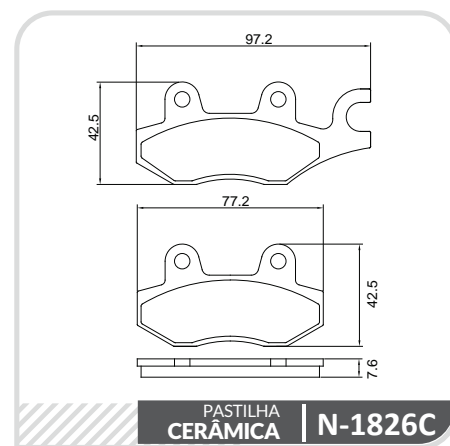
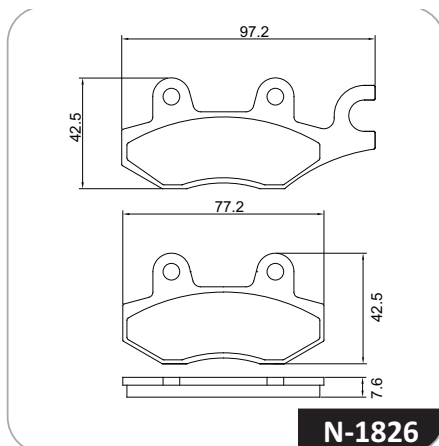
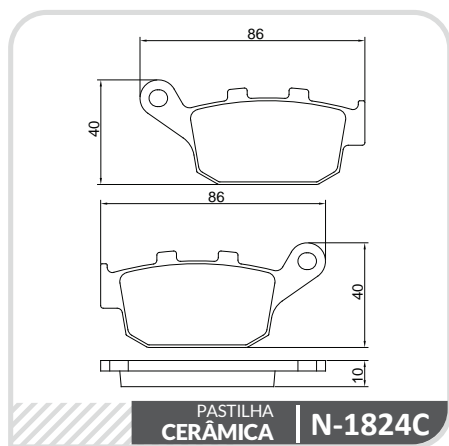

# Desenhos **Técnicos** Pastilhas

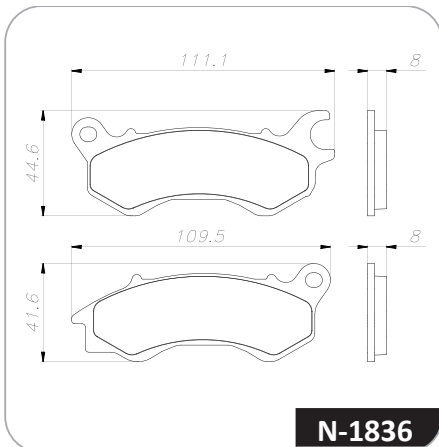

**N-1836**



PASTILHA  
CERÂMICA | **N-1838C**

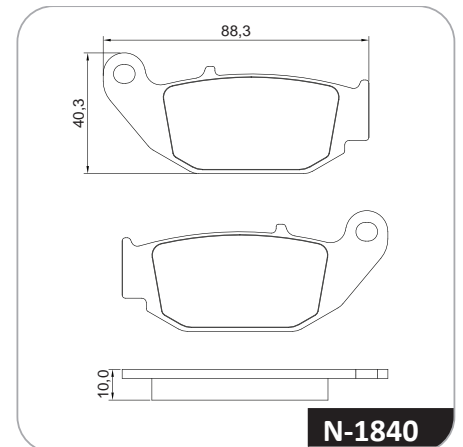

**N-1840**

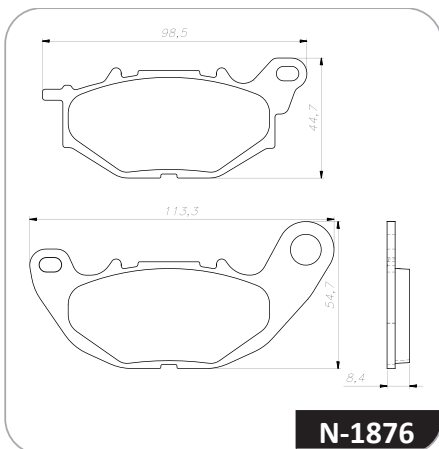

**N-1876**

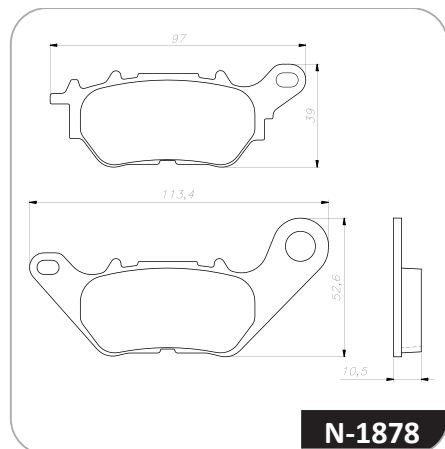

**N-1878**

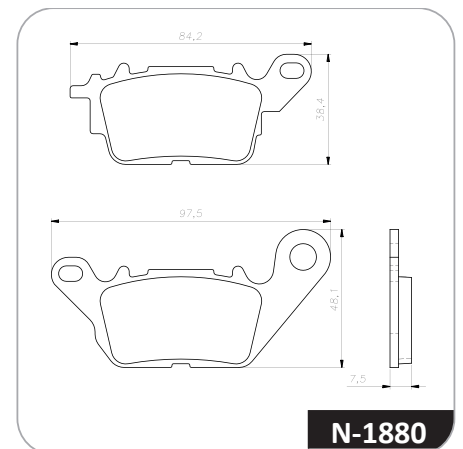

**N-1880**

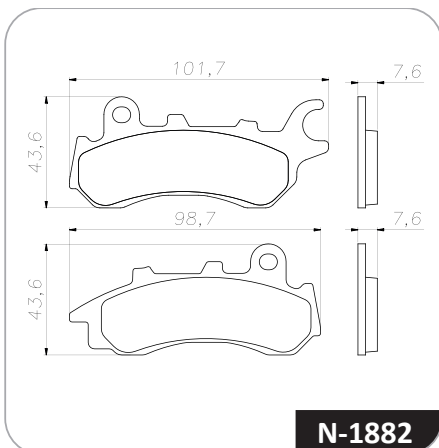

**N-1882**

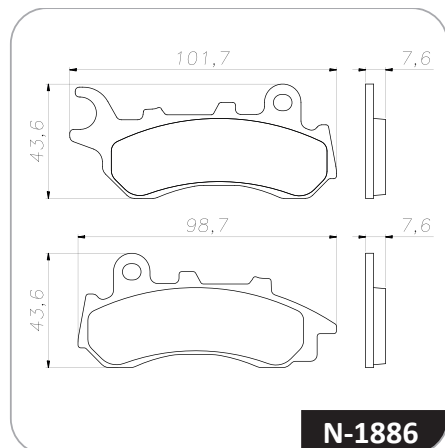

**N-1886**

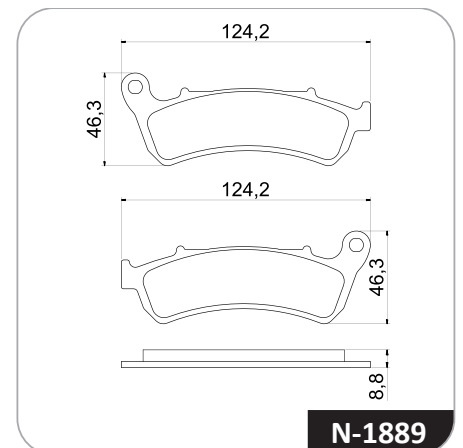

**N-1889**

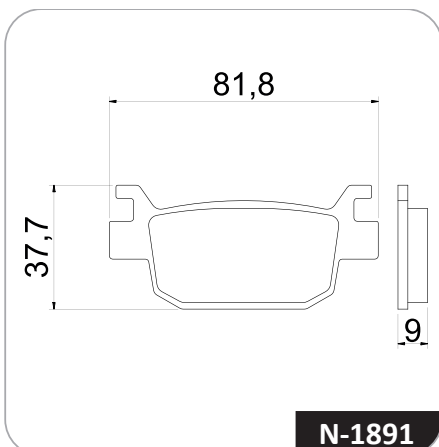

**N-1891**

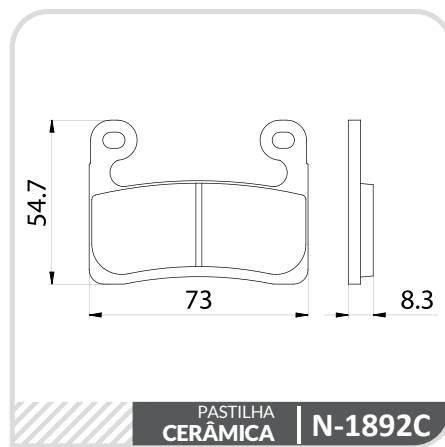

PASTILHA  
CERÂMICA | **N-1892C**

# Desenhos **Técnicos** Patins

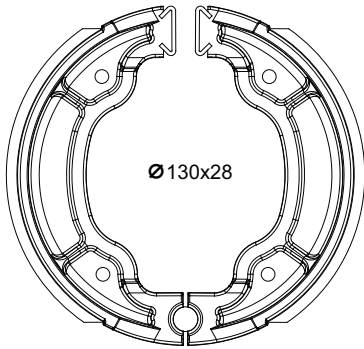

Ø130x28

**0301-CP**

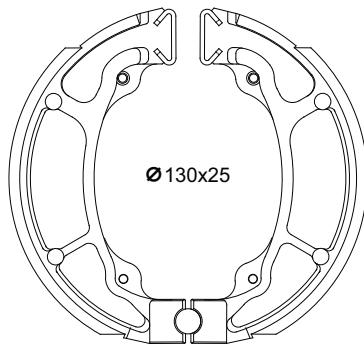

Ø130x25

**0302-CP**

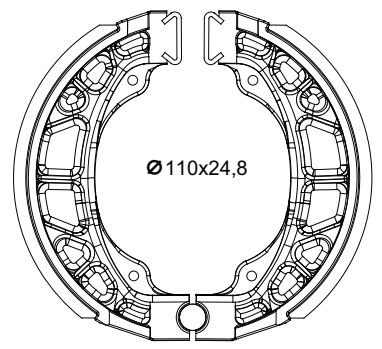

Ø110x24,8

**0304-CP**

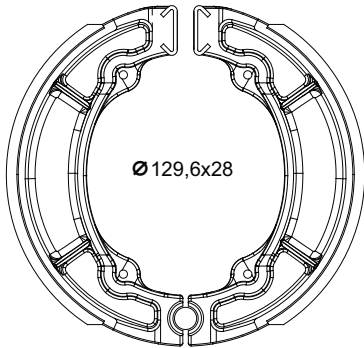

Ø129,6x28

**0307-CP**

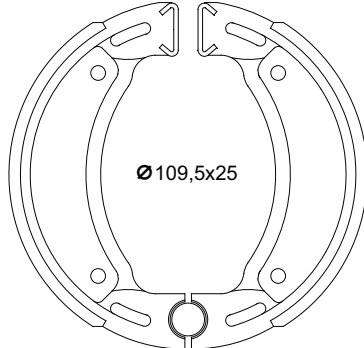

Ø109,5x25

**0308-CP**

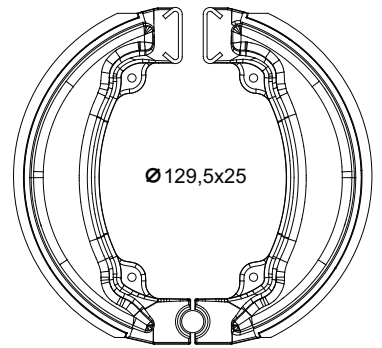

Ø129,5x25

**0312-CP**

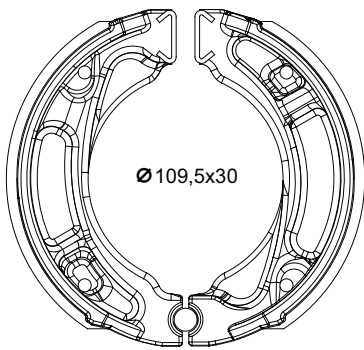

Ø109,5x30

**0313-CP**

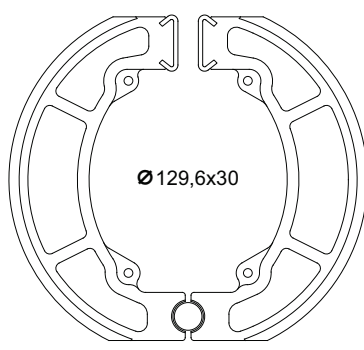

Ø129,6x30

**0314-CP**

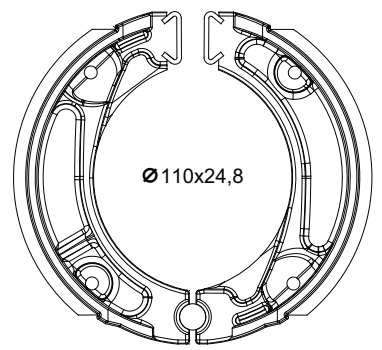

Ø110x24,8

**0320-CP**

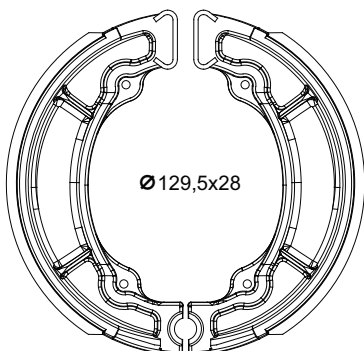

Ø129,5x28

**0321-CP**

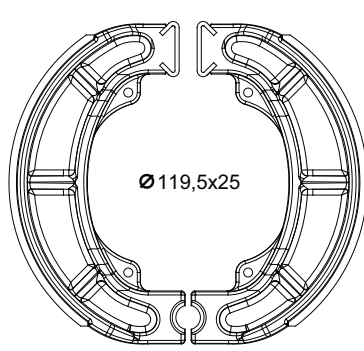

Ø119,5x25

**0322-CP**

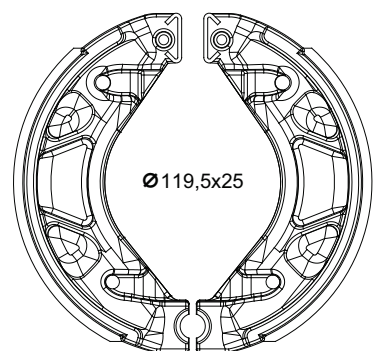

Ø119,5x25

**0323-CP**



# Nosso Suporte Online

Trabalhamos para oferecer o máximo de informações para atender as exigências dos nossos clientes.

Para isso você conta com diversos serviços, seja através de aplicativos, sistema de consulta pelo computador, download dos nossos catálogos ou através da nossa Central de Atendimento Técnico.

## Tudo em um **só lugar**

Aponte seu celular para o nosso QR Code para acessar todos os nossos principais canais de comunicação, como nosso aplicativo, nossas redes sociais e nosso site.



 /Cobreq

 /Cobreq

 @Cobreq

 /CobreqFreios

# TECNOLOGIA MUNDIAL NO SEU VEÍCULO



**TMD**FRICION  
**cobreq.com.br**  
**0800 011-1992**  
sac.cobreq@tmdfriction.com